

MHF I with LOCK function

Instruction Manual

1	S18608	Sep./21/2018	Y.Fukumoto		K.Narita
0	S17459	Jun./20/2017	Y.Fukumoto		K.Narita
Rev.	ECN	Date	Prepared by	Checked by	Approved by

This manual is to explain the mate & unmate methods and important points in handling of MHFI LK connector plug with cable for the purpose of proper use.

【 CONNECTOR INSERTION MANUAL】

① How to hold a cable connector

Hold the both ends of cable connector as show in Fig.1.

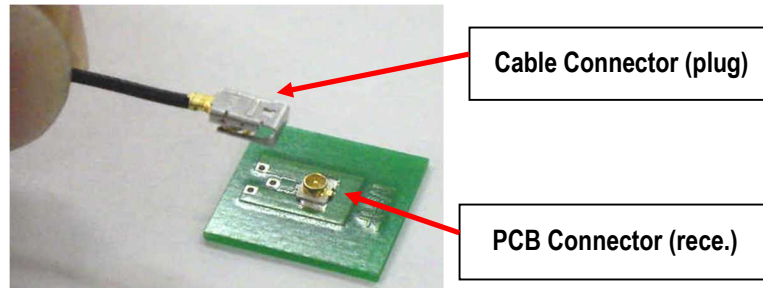
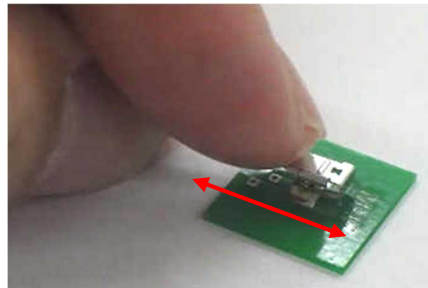

Fig.1

② Which direction to mate

Set connectors of the board side and of the cable side as shown in Fig.2.

Please check they are set firmly by moving back and forth slightly.



Move back and forth slightly.
They should not move.

Fig.2

③ How to mate

Push cable connector at it's center location vertically as show in Fig.3. When click sound can be heard "the connector mating action is complete".

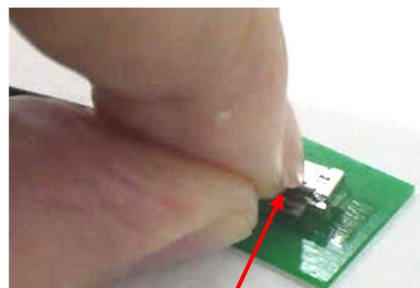

Push at connector center

Fig.3

CAUTION

- Please make sure to set the cable side connector parallel to the board. If you mate in not parallel condition as shown in Fig.4-2, connector will be damaged.

Correct connector mating Parallel <OK>

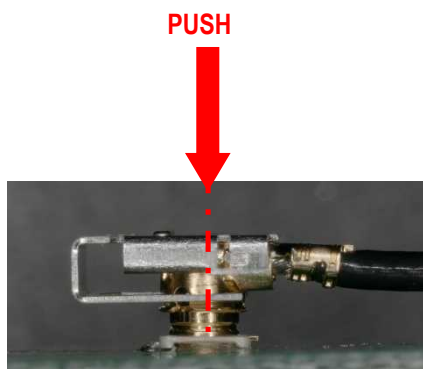

Fig.4-1

Wrong connector mating Not parallel <NG>

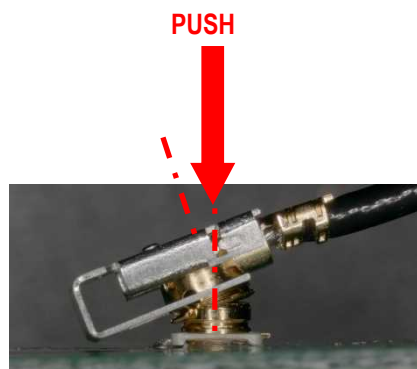

Fig.4-2

[How to Lock]

Slide the lock parts it shown Fig.5-1.

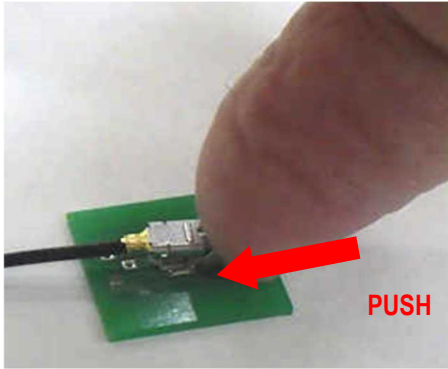

Fig.5-1

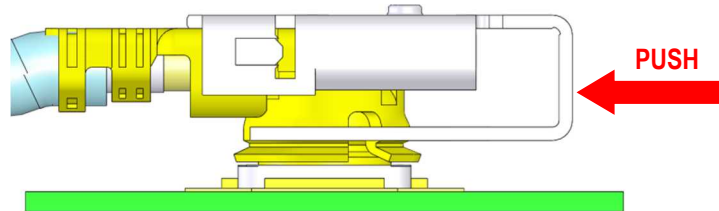

Fig.5-2

CAUTION

- As shown in Fig.6-2, please slide until the connector comes to the whole hole.
- In the state of Fig. 6-3 , the connector fitting holding force decrease.
- Do not add excessive force.

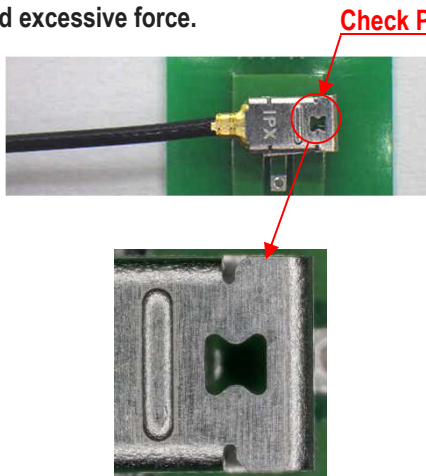

Fig.6-1 Unlock state

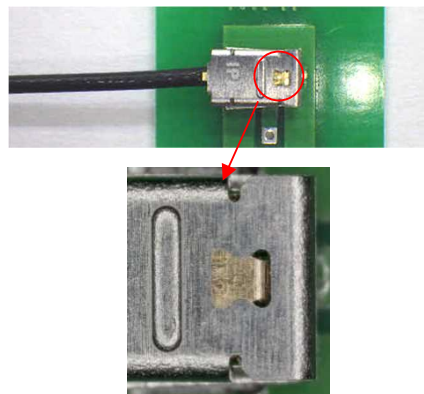

Fig.6-2 Lock state

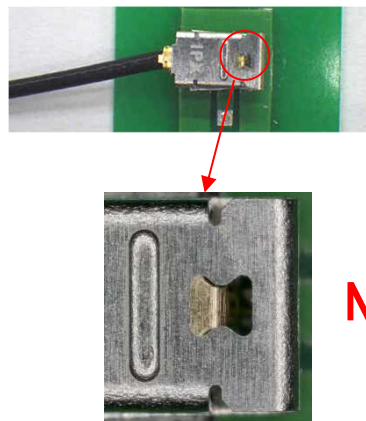

Fig.6-3 Half lock state

【 CONNECTOR UNMATING MANUAL】

There are two ways to unlock and un-mate.

- By hand [page 5]
- By unmating jig [page 6]

【 How to Un-LOCK by a hand】

Slide the lock parts as shown in figures 7-1 and 7-2.

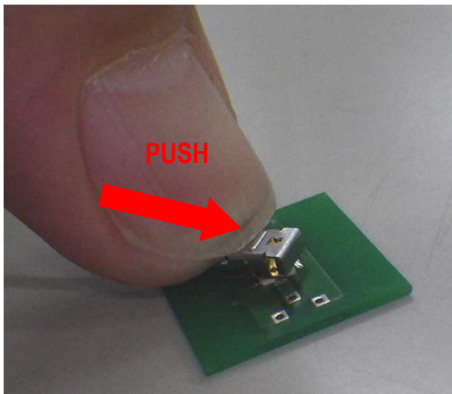

Fig.7-1

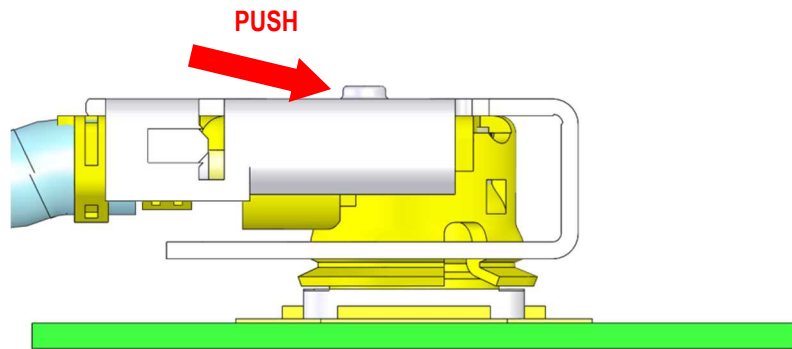

Fig.7-2

【 How to un-mate cable connector by a hand】

Pull plug connector vertically against the PCB surface.

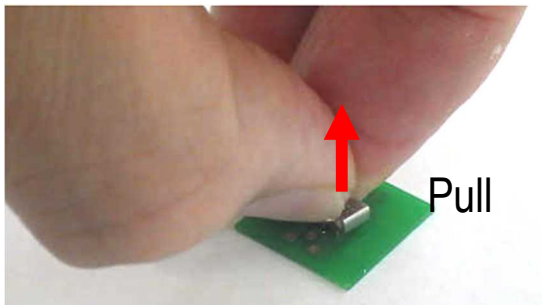

Fig.8-1

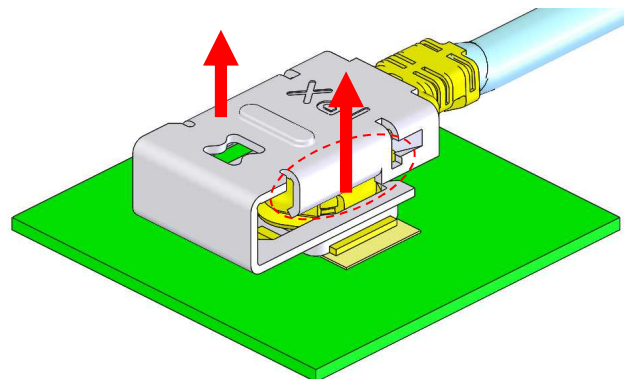

Fig.8-2

CAUTION

- Do not pull cables to unmate cable connectors.
- Pull plug connector vertically by holding the hooks on connector side surfaces.

【 How to unlock by the unmating jig】 ※The unmating jig's parts number is 91026-0001

1. Place positioning guide on the lock. [Fig.9-1.]
2. Clip lock with jig and slide it to unlock.. [Fig. 9-2]

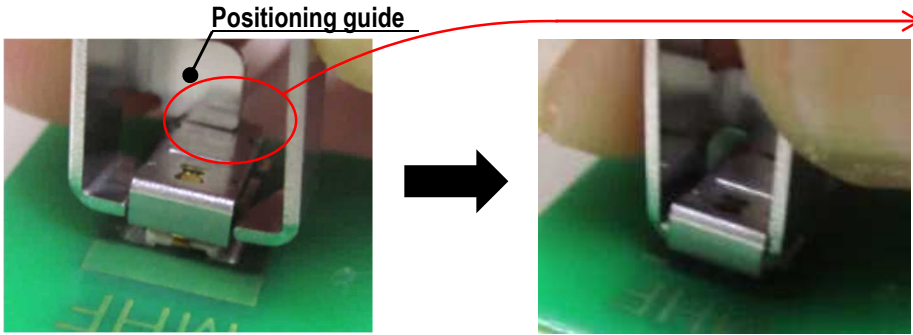

Place positioning guide on the lock

Fig.9-1

Lock clipped with jig

Fig.9-2

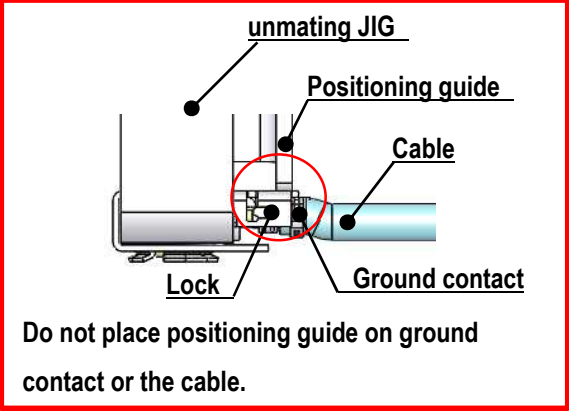

Reference: Fig.9-3 & 9-4 shows how lock slide to unlock.

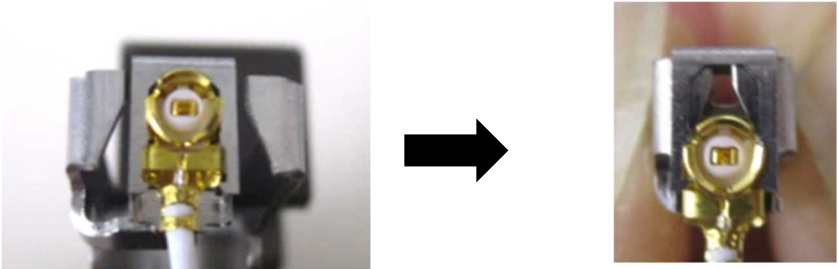

Clipping lock parts with unmating jig

Fig.9-3

The lock parts slides automatically and lock will be released

Fig.9-4

【 How to un-mate cable connector by the un-mate JIG】

Pull up plug connector vertically against the PCB surface.



Pull

Fig.10

CAUTION

- Do not pull cables to unmate cable connectors.
- Pull plug connector vertically by holding the hooks on connector side surfaces.

[CAUTION IN CABLE CONNECTOR HANDLING]

- In the case of figure 11, it has possibility to damage to the housing and come off from rece. connector.
Especially when operator give continuous force to the direction (black allow), the tendency become higher.
So please take care of handling of harness.

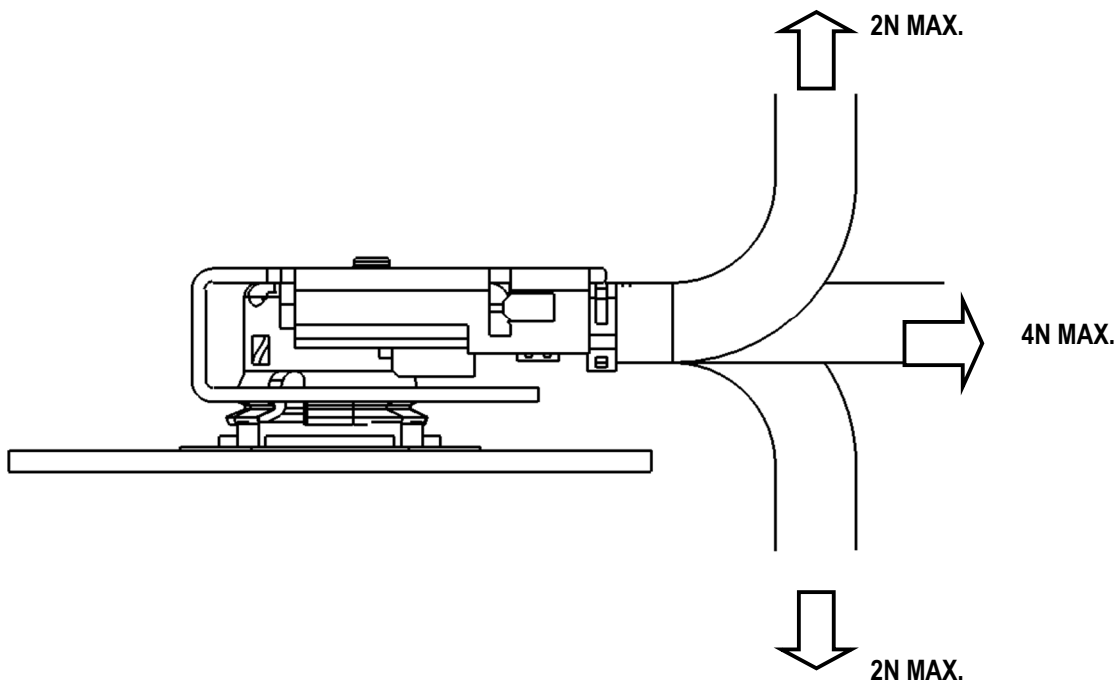
Fig.11