

EVAFLEX® 5-SE-G HT

Part No. 20899-0**E-01

Product Specification

Qualification Test Report No. TR-18020

3	S24170	May 13, 2024	E.Tanaka	M.Muro	T.Masunaga
2	S22016	January 13, 2022	M.Muro	-	H.Ikari
1	S20422	August 17, 2020	T.Tanigawa	T.Kurachi	Y.Shimada
0	S19216	March 26, 2019	M.Nakamura	T.Kurachi	H.Ikari
Rev.	ECN	Date	Prepared by	Checked by	Approved by

1. Scope

This product specification defines the test conditions and the performances of the EVAFLEX 5-SE-G HT Connector , a board-to-FPC/FFC connector of 0.5mm contact pitch.

2. Product Name and Parts No.

2.1 Product Name

EVAFLEX 5-SE-G HT

2.2 Parts No.

20899-0**E-01

3. Rating

3.1 Operating Conditions

Amperage: 0.35A AC/DC (per contact)

Available for all contacts

0.5A AC/DC (per contact)

Available up to 15 contacts

Voltage: 50V AC (per contact)

Operating temperature: 233 to 398K(-40°C to +125°C) (Containing temperature rise by current)

Operating humidity: 85% max

3.2 Storage Conditions

Storage temperature: 248 to 333K(-25°C to 60°C)

Storage humidity: 85% max. (Non-condensing)

3.3 Applicable Lead Thickness

$t=0.3\pm 0.03$ mm

3.4 Applicable Lead Plating

Au over Ni

4. Test and Performance

Test Condition

This initial test is equal to it's at shipping condition and unless otherwise specified, all tests and measurements shall be performed under the following conditions in accordance with MIL-STD-202.

Temperature: 288K to 308K(15°C to 35°C)

Pressure: 866hPa to 1066hPa (650mmHg to 800mmHg)

Relative humidity: 45 to 75% R.H.

4.1. Electrical Performance

1. Contact resistance

Reference standard: MIL-STD-202, Method 307

Test conditions: Solder the connector to the test board and connect the applicable Lead, then, measure the contact resistance as shown in Fig.1 by the four terminals method. Apply the open circuit voltage of 20mV MAX. DC and the closed circuit current of 1mA MAX. DC

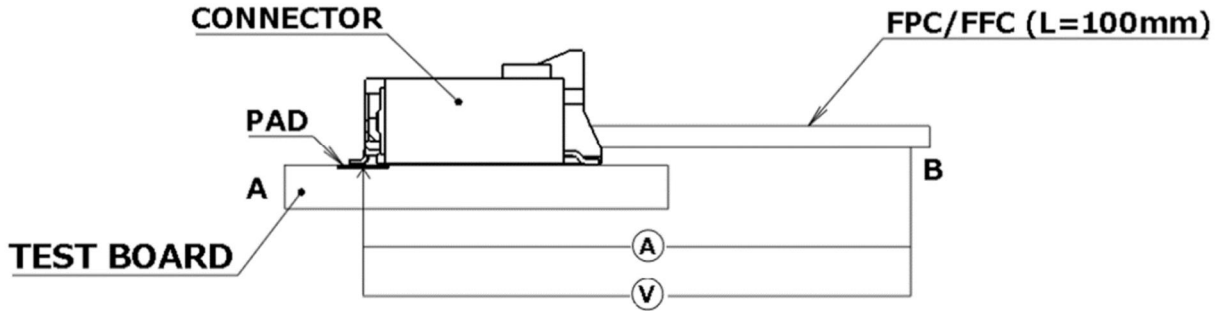

Fig.1

Pass criteria: Initial: 60 mΩMAX. After testing: Δ R40 mΩ MAX

2. Insulation resistance

Reference standard: MIL-STD-202, Method 302

Test conditions: Solder the connector to the test board and connect the applicable Lead, then apply DC 250 V between the neighboring contacts.

Pass criteria: 500 MΩ MIN.

3. Dielectric withstanding voltage

Reference standard: MIL-STD-202, Method 301

Test conditions: Solder the connector to the test board and connect the applicable Lead, then apply AC 250V(rms) between the neighboring contacts for a minute.

Pass criteria: No abnormalities such as creeping discharge, flashover, insulator breakdown occur.

4. Temperature rising

Reference standard: -

Test conditions: Solder the connector to the test board and connect the applicable Lead, then, apply the rating current to each contact and measure temperature rise around the connector.

Pass criteria: Over ambient Δ T30 °C MAX.

4.2. Mechanical Performance

1. Mating force and Un-mating force	
Reference standard:	-
Test conditions:	Solder the connector to the test board, then place the board and plug on push-on/pull-off machine, measure of initial and mating/unmating 50 cycles at a speed 25 ± 3 mm/min. along the mating axis. LOCK shall be released before measuring un-mating force.
Pass criteria:	Mating force 20 P: 15.0 N MAX. 30 P: 22.0 N MAX. 40 P: 29.0 N MAX. 50 P: 36.0 N MAX. 60 P: 43.0 N MAX. Unmating force 20 P: 2.00 N MIN. 30 P: 2.70 N MIN. 40 P: 3.40 N MIN. 50 P: 4.10 N MIN. 60 P: 4.80 N MIN.

2. Durability	
Reference standard:	-
Test conditions:	Solder the connector to the test board, then place the board and plug on the push-on/pull-off machine, and repeat mating and unmating 50cycles at a speed 25 ± 3 mm/min. along the mating axis.
Pass criteria:	Contact resistance: Shall meet 4.1.1

3. Contact retention force	
Reference standard:	-
Test conditions:	Place the connector on the push-on/pull-off machine, then apply force on the contact head and push the contact along the direction opposite to the contact insertion at a speed of 25 ± 3 mm/min. Measure the force when the contact dislodges the connector.
Pass criteria:	Contact retention force: 0.30N MIN.

4. Hold down retention force	
Reference standard:	-
Test conditions:	Place the connector on the push-on/pull-off machine, then apply force on the hold down head and push the hold down along the direction opposite to the hold down insertion at a speed of 25 ± 3 mm/min. Measure the force when the hold down dislodges the connector.
Pass criteria:	Hold down retention force: 1.47N MIN.

5. FFC/FPC retention force	
Reference standard:	-
Test conditions:	Place the connector on the push-on/pull-off machine and then apply force on the cable along the direction at a speed 25 ± 3 mm/min. Measure the force when the cable dislodges the connector.
Pass criteria:	20P: 11.0 N MIN. 30P: 11.7 N MIN. 40P: 12.4 N MIN. 50P: 13.1 N MIN. 60P: 13.8 N MIN.

4.2. Mechanical Performance

6. Vibration	
Reference standard:	MIL-STD-202, Method 201
Test conditions:	Solder the connector to the test board and connect the applicable Lead, then, set them on the vibrator. Then apply the following vibration. During the testing, run 100mA DC to check electrical discontinuity. Frequency: 10Hz→55Hz→10Hz/approx. 1min. Directions: 3 mutually perpendicular direction. Total Amplitude: 1.52mm Sweep duration: 2 hours for each direction, a total of 6 hours.
Pass criteria:	Contact resistance: Shall meet 4.1.1. Electrical discontinuity: No electrical discontinuity greater than 1μs shall occur. Appearance: No abnormality adversely affecting the performance shall occur.

7. Shock	
Reference standard:	MIL-STD-202, Method 213, Condition A.
Test conditions:	Solder the connector to the test board, connect the applicable Lead, and set them on the shock machine. Then apply the following shock. MAX.G: 50G Duration: 11msec Wave Form: Half Sinusoidal Directions: 6 mutually perpendicular direction Cycle: 3 cycles about each direction
Pass criteria:	Contact resistance: Shall meet 4.1.1. Electrical discontinuity: No electrical discontinuity greater than 1μs shall occur. Appearance: No abnormality adversely affecting the performance shall occur.

4.3. Environmental Performance

1. Thermal shock	
Reference standard:	-
Test conditions:	Solder the connector to the test board and connect the applicable Lead, then, expose them to the following environment. Temperature: 218K(-55°C),30min.→398K(125°C),30min. Transition time: 5min. MAX. No. of cycles: 100 cycles
Pass criteria:	Contact resistance: Shall meet 4.1.1. Appearance: No abnormality adversely affecting the performance shall occur.

2. High temperature life	
Reference standard:	-
Test conditions:	Solder the connector to the test board and connect the applicable Lead, then, expose them to the following environment. Temperature: 398±2K (125±2°C) Duration: 1000 hours
Pass criteria:	Contact resistance: Shall meet 4.1.1. Appearance: No abnormality adversely affecting the performance shall occur.

4.3. Environmental Performance

3. Humidity (Steady state)	
Reference standard:	MIL-STD-202, Method 103, Condition A.
Test conditions:	Solder the connector to the test board and connect the applicable Lead, then, expose them to the following environment. Temperature: 313±2K (40±2°C) Humidity: 90~95%RH Duration: 240 hours
Pass criteria:	Contact resistance: Shall meet 4.1.1. Insulation resistance: Shall meet 4.1.2. Dielectric withstanding voltage: Shall meet 4.1.3. Appearance: No abnormality adversely affecting the performance shall occur.

4. Humidity (Cycling)	
Reference standard:	MIL-STD-202, Method 106.
Test conditions:	Solder the connector to the test board and connect the applicable Lead, then, expose them to the following environment. Temperature: 263~338K (-10~65°C) Humidity: 90~98%RH Duration: 10cycles (240hours)
Pass criteria:	Contact resistance: Shall meet 4.1.1. Insulation resistance: Shall meet 4.1.2. Dielectric withstanding voltage: Shall meet 4.1.3. Appearance: No abnormality adversely affecting the performance shall occur.

5. Salt water spray	
Reference standard:	MIL-STD-202, Method 101, Condition B.
Test conditions:	Solder the connector to the test board and connect the applicable Lead, then, expose them to the following environment. Temperature: 308±2K (35±2°C) Salt water density: 5±1% [by weight] Duration: 48 hours
Pass criteria:	Contact resistance: Shall meet 4.1.1. Appearance: No abnormality adversely affecting the performance shall occur.

6. H ₂ S gas	
Reference standard:	-
Test conditions:	Solder the connector to the test board and connect the applicable Lead, then, expose them to the following environment. Temperature: 313±2K (40±2°C) Relative humidity: 80±5%RH Gas: H ₂ S 3±1ppm Duration: 96 hours
Pass criteria:	Contact resistance: Shall meet 4.1.1. Appearance: No abnormality adversely affecting the performance shall occur.

4.4.Others

1. Solder ability	
Reference standard:	-
Test conditions:	Dip the solder tine of the contact in the solder bath at $518 \pm 5K$ ($245 \pm 5^{\circ}C$) for 5 ± 0.5 seconds after immersing the tine in the flux of RMA or R type for 5 to 10 seconds.
Pass criteria:	More than 95% of the dipped surface shall be evenly wet.

2. Soldering heat resistance	
Reference standard:	-
Test conditions:	Reflow temperature as shown in Fig.2. The number of times of Reflow is within 2.

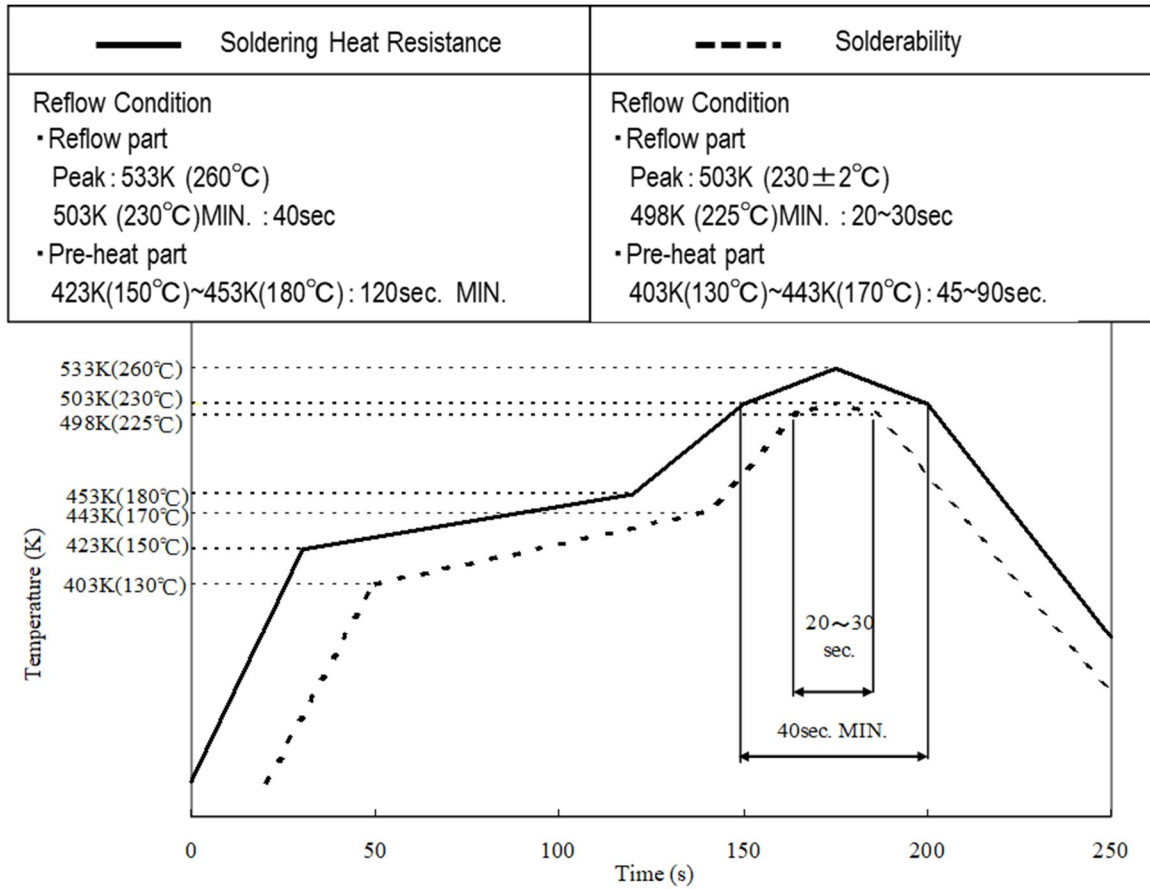

Fig.2

Pass criteria:	No abnormality adversely affecting the performance shall not occur.
----------------	---

4.5 Test Sequence and Specimen Quantity

Table 1 Test Sequence and Sample Quantity

Test Item	Group													
	A	B	C	D	E	F	G	H	J	K	L	M	N	P
Contact Resistance		2,6				1,3,5	1,3	1,3	1,5	1,5	1,3	1,3		
Insulation Resistance									2,6	2,6				
D. W. Voltage									3,7	3,7				
Temperature rising	1													
Mating Force		1,5												
Un-mating Force		3,7												
Durability		4												
Contact Retention Force			1											
Hold down Retention Force				1										
FFC/FPC Retention Force					1									
Vibration						2								
Shock						4								
Thermal Shock							2							
High Temperature Life								2						
Humidity (Steady State)									4					
Humidity (Cycling)										4				
Salt Water Spray											2			
H2S Gas												2		
Solder ability													1	
Soldering Heat Resistance														1
Specimen Quantity.	5 pcs.	5 pcs.	20 pos.	10 pos.	5 pcs.	5 pcs.	5 pcs.	5 pcs.	5 pcs.	5 pcs.	5 pcs.	5 pcs.	10 pcs.	10 pcs.

※Numbers indicate sequence in which tests are performed.

5. Recommended Metal Mask

Refer to drawing for the recommended metal mask thickness and opening dimension.

6. Precautions for Handling Connectors

Refer to instruction manual HIM-18018 for the handling of EVAFLEX 5-SE-G HT.