

# DW-5

(0.5mm pitch FPC & Discrete cable)

Part No. Plug:20598-0\*\*T-0\* Receptacle:20597-0\*\*E-0\*

## Product Specification

Qualification Test Report No. TR-13103

4	S24188	May 20, 2024	E.Tanaka	M.Muro	T.Masunaga
3	S22019	January 17, 2022	S.Shigekoshi	M.Muro	H.Ikari
2	S17268	April 21, 2017	Y.O		TAK
1	S15232	May 29, 2015	Y.F		Tom
Rev.	ECN	Date	Prepared by	Checked by	Approved by

## 1. Scope

This product specification defines the test conditions and the performances of the DW-5 , FPC to board and wire to board connector for FPC and Discrete cable on pitch of 0.5mm.

## 2. Product Name and Parts No.

### 2.1 Product Name

DW-5

### 2.2 Parts No.

Plug: 20598-0\*\*T-0\*

Receptacle: 20597-0\*\*E-0\*

## 3. Rating

### 3.1 Applicable Cable

AWG#34,

Applicable Lead Thickness of FPC

$t=0.20\pm 0.03$  Thermosetting adhesive

### 3.2 Operating Conditions

Amperage: 0.5A AC/DC [FPC] (per contact)

0.7A AC/DC [AWG#34] (per contact)

Voltage: 50V AC (per contact)

Operating temperature: 233 to 358K(-40°C to 85°C) (Containing temperature rise by current)

Operating humidity: 85% max

### 3.3 Storage Conditions

Storage temperature: After soldering 248 to 333K(-25°C to 60°C)

Before soldering 233 to 328K(-40°C to 55°C)

Storage humidity: 85% max. (Non-condensing)

Storage period: Maximum storage period: Within one year from delivery date, under sealed condition.

## 4. Test and Performance

### Test Condition

Unless otherwise specified, all tests and measurements shall be performed under the following conditions in accordance with MIL-STD-202.

Temperature: 288K to 308K(15°C to 35°C)

Pressure: 866hPa to 1066hPa(650mmHg to 800mmHg)

Relative humidity: 45 to 75% R.H.

## 4.1 Electrical Performance

No	Items	Test Conditions	Specifications
1	Contact Resistance	Solder the receptacle connector to the test board and mate the plug connector or applicable Lead together, then measure the contact resistance as shown in Fig.2,3 by the four terminal method. Apply the low level condition of 20mV MAX. DC for the open circuit voltage and 10mA MAX. DC for the closed circuit current in accordance with MIL-STD-202G, Method 307.	<u>Plug Conn.(Discrete cable)</u> Initial : 150mΩMAX. After : ΔR 40mΩ MAX  <u>FPC</u> Initial : 40mΩ After : ΔR 20mΩ MAX  ※Initial contains conductor resistance 100mΩ(AWG#34) of a cable 100mm.
2	Dielectric Withstanding Voltage	Mate the receptacle and plug connector or applicable Lead together, then apply AC 250V(rms)between the neighboring contacts for a minute in accordance with MIL-STD-202G,Method 301.	No creeping discharge, flashover, nor insulator breakdown shall occur.
3	Insulation Resistance	Mate the receptacle and the plug connector or applicable Lead together, then apply DC500V between the neighboring contacts in accordance with MIL-STD-202G, Method 302.	<u>Plug Conn.</u> Initial : 1000 MΩ MIN. After testing : 500MΩ MIN.  <u>Applicable Lead</u> Initial : 100 MΩ MIN. After Testing : 100 MΩ MIN.
4	Temperature rising	Mate the plug and receptacle connector together, then apply rating current per contact.	<u>Over ambient</u> ΔT : 30°C MAX.

## 4.2. Mechanical Performance

No	Items	Test Conditions	Specifications
1	Actuator operating force	Solder the connector to the test board and insert the plug connector or applicable Lead to the connector, then, lock and unlock the actuator.	<u>Locking Force</u> Initial : 0.6N(61gf) × (n+2) MAX 20 cycles: 0.6N(61gf) × (n+2) MAX  <u>Unlocking Force</u> Initial : 0.05N(5gf) × (n+2) MIN 20 cycles: 0.05N(5gf) × (n+2) MIN  ※ "n" is the number of pin
2	Plug and FPC Retention Force	Insert the plug connector or applicable Lead into the connector, place them on the push-on/pull-off machine, then, un-mate the Lead at the speed of 25±3mm/min. along the mating axis.	<u>Plug and FPC Retention Force</u> Initial: 0.15N(15gf) × n + 2.0N MIN After Test: 0.15N(15gf) × n + 2.0N MIN
3	Durability	Solder the connector to the test board, insert the plug connector or applicable Lead to the connector, then operate actuator 20cycles repeatedly.	[Contact Resistance] Shall meet 4.1.1.
4	Contact Retention Force	Place the connector on the push-on/pull-off machine, then apply force on the contact head and push the contact along the direction opposite to the contact insertion at a speed of 25 ±3mm/min. Measure the force when the contact dislodges the connector.	Plug Retention Force 0.6 N (61.2gf) MIN.  Receptacle Retention Force 0.5 N (51.0gf) MIN
5	Lock of Receptacle Retention Force	Place the connector on the push-on/pull-off machine and apply force to the lock in the direction opposite to insertion at the speed of 25±3mm/min. Measure the force when the lock came off from the connector.	Lock Retention Force 0.5N (51gf) MIN
6	Hold Down of RECE . Retention Force	Place the connector on the push-on/pull-off machine and apply force to the hold down in the direction opposite to insertion at the speed of 25±3mm/min. Measure the force when the hold down came off from the connector.	Hold Down Retention Force 0.5N (51gf) MIN
7	Cable Retention Force	Place the plug connector on the push-on/pull-off machine, then apply force on the cable along the direction at a speed of 25±3mm/min. Measure the force when the cable dislodges the plug connector.	Cable Retention Force 6P : 4.12N(0.4kgf) MIN 8P : 5.49N(0.5kgf) MIN 10P : 6.86N(0.7kgf) MIN

No	Items	Test Conditions	Specifications
8	Vibration	<p>Solder the receptacle connector to the test board, then mate plug connector or applicable Lead, and place them on the vibrator. Then apply the following vibration in accordance with MIL-STD-202G, Method 201A.</p> <p>PLUG CONN. : During the testing, run 100mA DC to check electrical discontinuity.</p> <p>Applicable Lead : During the testing, run 1mA DC to check electrical discontinuity.</p> <p>Frequency : 10Hz→55Hz→10Hz/approx 1min.</p> <p>Directions : Three mutually perpendicular direction.</p> <p>Total Amplitude : 1.52mm</p> <p>Sweep duration : 2 hours for each direction, a total of 6 hours.</p>	<p>[Contact Resistance] Shall meet 4.1.1.</p> <p>[Electrical discontinuity] No electrical discontinuity greater than 1μs shall occur.</p> <p>[Appearance] No abnormality adversely affecting the performance shall occur.</p>
9	Shock	<p>Solder the receptacle connector to the test board, then mate plug connector or applicable Lead, and place them on the shock machine. The apply the following shock in accordance with MIL-STD-202G, Method 213B, Condition A.</p> <p>PLUG CONN. : During the testing, run 100mA DC to check electrical discontinuity.</p> <p>Applicable Lead : During the testing, run 1mA DC to check electrical discontinuity.</p> <p>MAX.G : 50G</p> <p>Duration : 11msec</p> <p>Wave Form : Half Sinusoidal</p> <p>Directions , cycle : 6 mutually perpendicular direction , 3 cycles about each direction</p>	<p>[Contact Resistance] Shall meet 4.1.1.</p> <p>[Electrical discontinuity] No electrical discontinuity greater than 1μs shall occur.</p> <p>[Appearance] No abnormality adversely affecting the performance shall occur.</p>
10	Fretting corrosion	<p>Solder the connector to the test board and connect the plug connector or applicable Lead, then, put them on the fretting corrosion machine. Apply the following shock.</p> <p>PLUG CONN.: During the testing, run 100mA DC to check electrical discontinuity.</p> <p>MAX. G..... 100G</p> <p>Cycles ..... 20,000 cycles (50~60Cycles/min.)</p>	<p>[Contact Resistance] Shall meet 4.1.1.</p> <p>[Electrical discontinuity] No electrical discontinuity greater than 1μs shall occur.</p> <p>[Appearance] No abnormality adversely affecting the performance shall occur.</p>

## 4.3. Environmental

No	Items	Test Conditions	Specifications
1	Thermal Shock	Solder the receptacle connector to the test board, then mate plug connector or applicable Lead, and expose them to the following environment in accordance with MIL-STD-202G, Method 107G, Condition B.  Temperature:233K [30 min.] → 358K [30 min.] (-40°C [30 min.] → +85°C [30 min.]) Transition time:5min. MAX. No. of cycles:5 cycles	[Contact Resistance] Shall meet 4.1.1. [Appearance] No abnormality adversely affecting the performance shall occur.
2	High Temperature Life	Solder the receptacle connector to the test board, then mate plug connector or applicable lead, and expose them to the following environment in accordance with MIL-STD-202G, Method 108A, Condition B.  Temperature:358±2K (85±2°C) Duration:250 hours	[Contact Resistance] Shall meet 4.1.1. [Contact Retention Force] Shall meet 4.2.4. [Appearance] No abnormality adversely affecting the performance shall occur.
3	Humidity (Steady State)	Solder the receptacle connector to the test board, then mate plug connector, and expose them to the following environment in accordance with MIL-STD-202G, Method 103B, Condition A. Temperature : 313±2K (40±2°C) Humidity : 90~95%RH Duration : 240 hours	[Contact Resistance] Shall meet 4.1.1. [Insulation Resistance] Shall meet 4.1.2. [Dielectric Withstanding Voltage] Shall meet 4.1.3. [Appearance] No abnormality adversely affecting the performance shall occur.
4	Humidity (Cycling)	Solder the receptacle connector to the test board, then mate plug connector, and expose them to the following environment in accordance with MIL-STD-202G, Method 106G. Temperature : 298~338K (25~65°C) Humidity : 90~98%RH Duration : 10cycles (240hours)	[Contact Resistance] Shall meet 4.1.1. [Insulation Resistance] Shall meet 4.1.2. [Dielectric Withstanding Voltage] Shall meet 4.1.3. [Appearance] No abnormality adversely affecting the performance shall occur.
5	Salt Water Spray	Solder the receptacle connector to the test board, then mate plug connector, and expose them to the following environment in accordance with MIL-STD-202G, Method 101E, Condition B. Temperature : 308±2K (35±2°C) Salt water density : 5±1% [by weight] Duration : 48 hours	[Contact Resistance] Shall meet 4.1.1. [Appearance] No abnormality adversely affecting the performance shall occur.

No	Items	Test Conditions	Specifications
6	H2S Gas	Solder the receptacle connector to the test board, then mate plug connector, and expose them to the following environment Temperature : 313±2K (40±2°C) Relative Humidity : 80±5%RH Gas : H2S 3ppm Duration : 96 hours	[Contact Resistance] Shall meet 4.1.1. [Appearance] No abnormality adversely affecting the performance shall occur.
7	SO2Gas	Solder the receptacle connector to the test board, then mate plug connector, and expose them to the following environment Temperature : 313K (40°C) Relative Humidity : 80%RH Gas : SO2 25ppm Duration : 96 hours	[Contact Resistance] Shall meet 4.1.1. [Appearance] No abnormality adversely affecting the performance shall occur.

## 4.4. Others

No	Items	Test Conditions	Specifications
1	Solder ability	<p>Expose the connector to the following condition for pretreatment. Dip the solder tine of the contact in the solder bath at <math>528\pm 2</math> K (<math>255\pm 2^{\circ}\text{C}</math>) in accordance with EIAJ-ET7404 (The wetting balance method). Use the solder paste M705-221MB (SENJU METAL INDUSTRY Co.,Ltd.)</p> <p>Condition of Pretreatment : PCT            Temperature:378K (<math>105^{\circ}\text{C}</math>)            Humidity:100%RH            Duration:4 hours</p>	<p>Zero cross time is 3 second MAX.            More than 95% of the dipped surface shall be evenly wet.</p>
2	Soldering Heat Resistance	<p>&lt;Reflow&gt;            ① Reflow part  <math>533\text{K}</math> (<math>260^{\circ}\text{C}</math>) Peak  <math>503\text{K}</math> (<math>230^{\circ}\text{C}</math>)MIN. 30~40 sec.            ② Pre-heat part  <math>423\sim 453\text{K}</math> (<math>150\sim 180^{\circ}\text{C}</math>) 60~120 sec.</p> <p>Refer the Reflow temperature to 5.            The number of times of Reflow is within 2.</p> <p>Condition of Pretreatment:PCT            Temperature:358K (<math>85^{\circ}\text{C}</math>)            Humidity:85%RH            Duration:24 hours</p> <p>&lt;Soldering iron&gt;            Temperature of soldering iron ···· <math>663\pm 10\text{K}</math> (<math>390\pm 10^{\circ}\text{C}</math>)            Heating time ···· <math>3.0\pm 0.5</math> sec.            Heating times ···· 2 twice</p>	<p>No abnormality adversely affecting the performance shall not occur.</p>



4.5 Test Sequence and Sample Quantity

Table 1 Test Sequence and Sample Quantity

Test Item	Group															
	A	B	C	D	E	F	G	H	J	K	L	M	N	P	Q	
Contact Resistance	2,6			1,3,5	1,3	1,3	1,3	1,5	1,5	1,3	1,3	1,3				
Insulation Resistance								2,6	2,6							
D. W. Voltage								3,7	3,7							
Temp. Life															1	
Act Locking Force	1,5															
Act Un-locking Force	3,7															
PLUGCONN/FPC Retention Force		1,3														
Durability	4	2														
Contact Retention Force			1,4													
H/D Retention Force			2,5													
Cable Retention Force	8															
Vibration				2												
Shock				4												
Fretting corrosion					2											
Thermal Shock						2										
High Temp. Life			3				2									
Humidity (Steady State)								4								
Humidity (Cycling)									4							
Salt Spray										2						
Gas (H <sub>2</sub> S)											2					
Gas (SO <sub>2</sub> )												2				
Solderability													1			
Soldering Heat Resistance														1		
Sample QTY.	5 pcs.	5 pcs.	20 Pos	5 pcs.	5 pcs.	5 pcs.	5 pcs.	5 pcs.	5 pcs.	5 pcs.	5 pcs.	5 pcs.	5 pcs.	10 pcs.	10 pcs.	5 pcs.

※The number of group is test sequence.

5. Reflow Temperature Profile

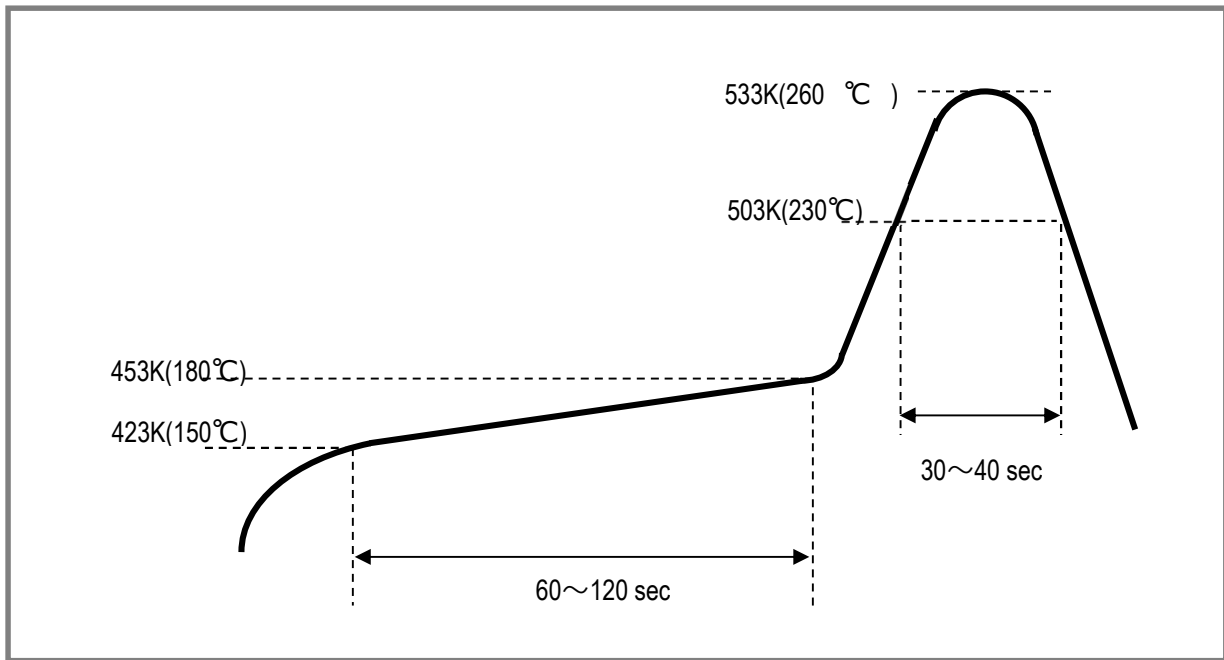

5.1. Recommended Metal Mask

Refer to DWG NO. 20597(Receptacle)

6. Measuring method

6.1. Measuring method of Contact Resistance

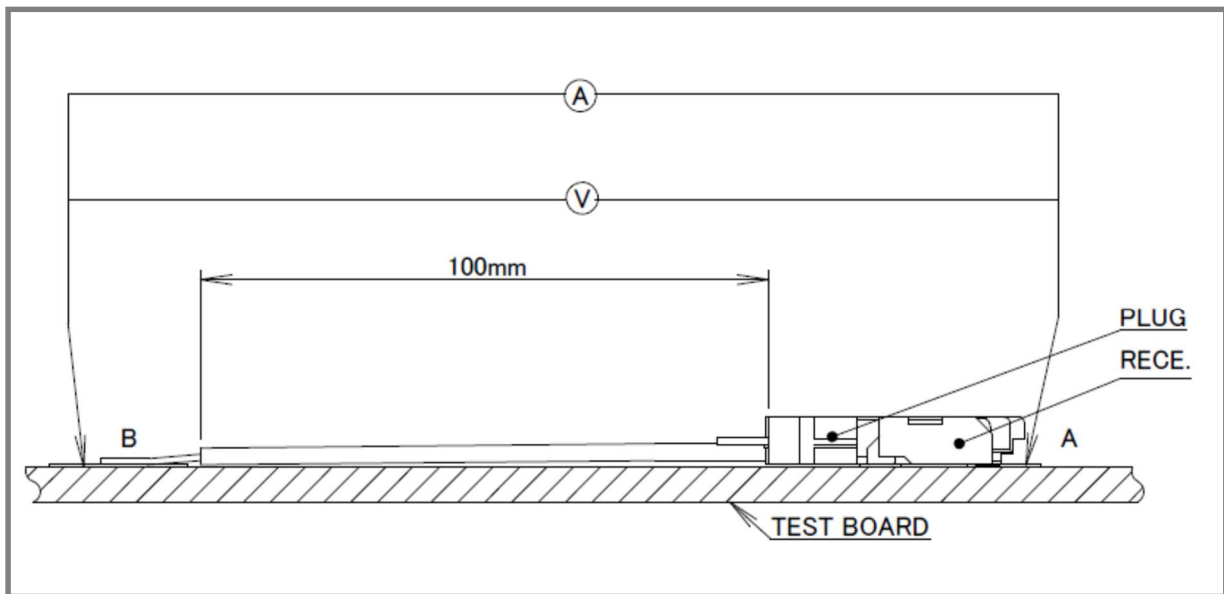

Contact Resistance =  $R_{AB}$

Fig.1 Contact Resistance Combination1

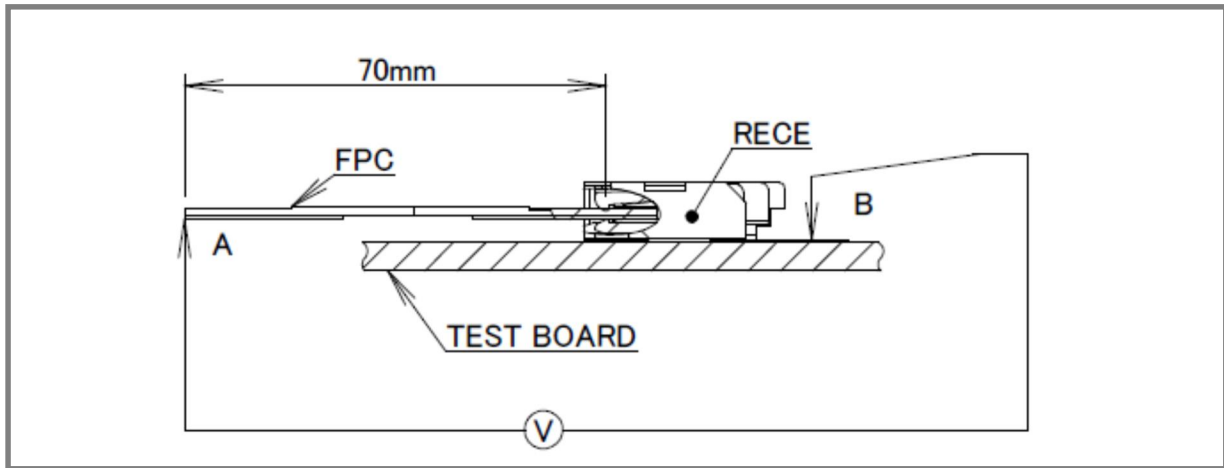

Contact Resistance =  $R_{AB}$  — Resistance of a 70mm length of Discrete cable or FPC cable.

Fig.2 Contact Resistance Combination2

### 7. Precautions for Handling Cable Connectors

Refer to instruction manual HIM-12019 for the handling of DW-5.