

MHF[®] I LK Harness with Receptacle Hand Tool Jig Narrow Pitch Type

Instruction Manual

2	S24418	October 11, 2024	M. Toida	-	K. Yufu
1	S23424	November 30, 2023	K.Motomura	K. Yufu	Y. Hashimoto
0	S23243	August 3, 2023	Y. Imaji	K. Yufu	Y. Hashimoto
Rev.	ECN	Date	Prepared by	Checked by	Approved by

This manual describes the mating/unmating of MHF I LK Harness and lock/unlock of LK methods and important handling points of the MHF I LK Harness for proper use.

【Products】

MHF I LK Harness

MHF I RECEPTACLE (Part Number: 20279-001E-**)

【About MHF I LK Hand Tool Jig Narrow Pitch Type】

The connector recommends using the jig shown in Figure 1 for unmating and locking/unlocking operation to avoid excessive stress to a cable connection point.

I-PEX Jig Part No. 91492-0001 (MHF I LK Hand Tool Jig Narrow Pitch Type)

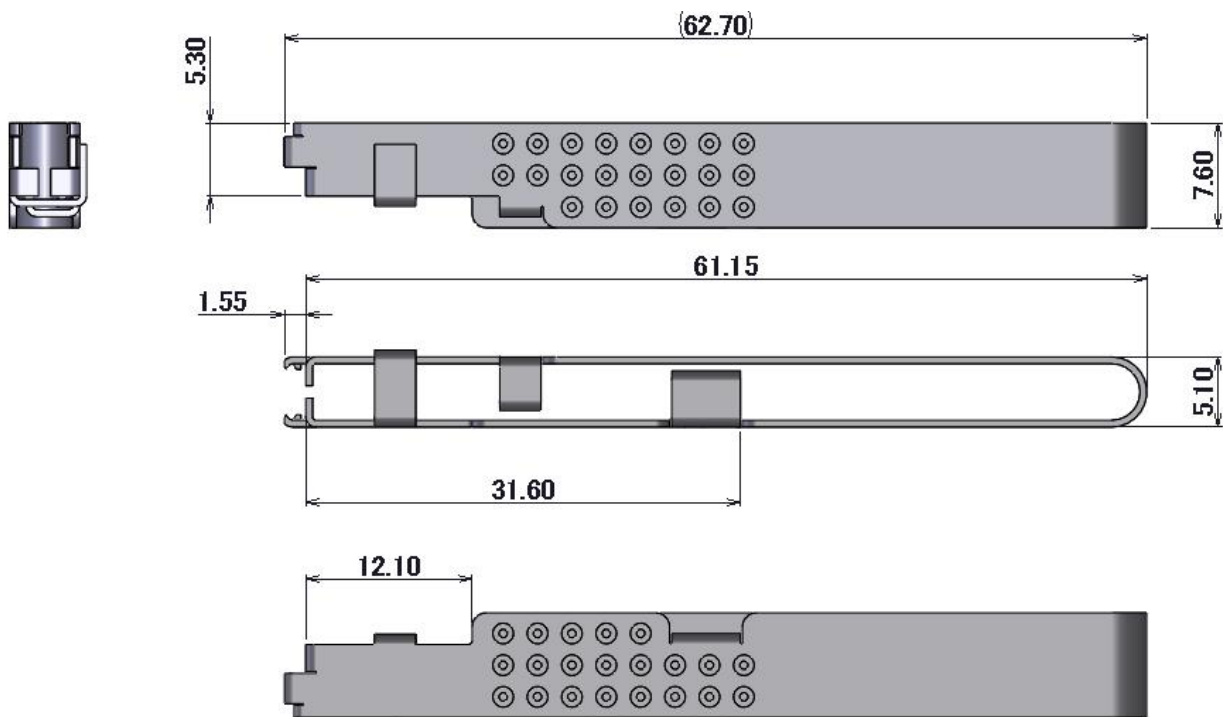

Figure 1 MHF I LK Hand Tool Jig Narrow Pitch Type

【Connector operation means】

Table 1. Connector operation means

Operation	Hands	Jig (Part No : 91492-0001)
Mate	Available	Unavailable
Lock	Available	Available (Recommended)
Unlock	Available	Available (Recommended)
Unmate	Unavailable	Available (Recommended)

【Connector Layout for MHF I LK Harness and Receptacle】

This MHF I LK Hand Tool Jig Narrow Pitch Type enables smooth unmating, locking, and unlocking operation in the narrow pitch layout of MHF I LK Harness as below.

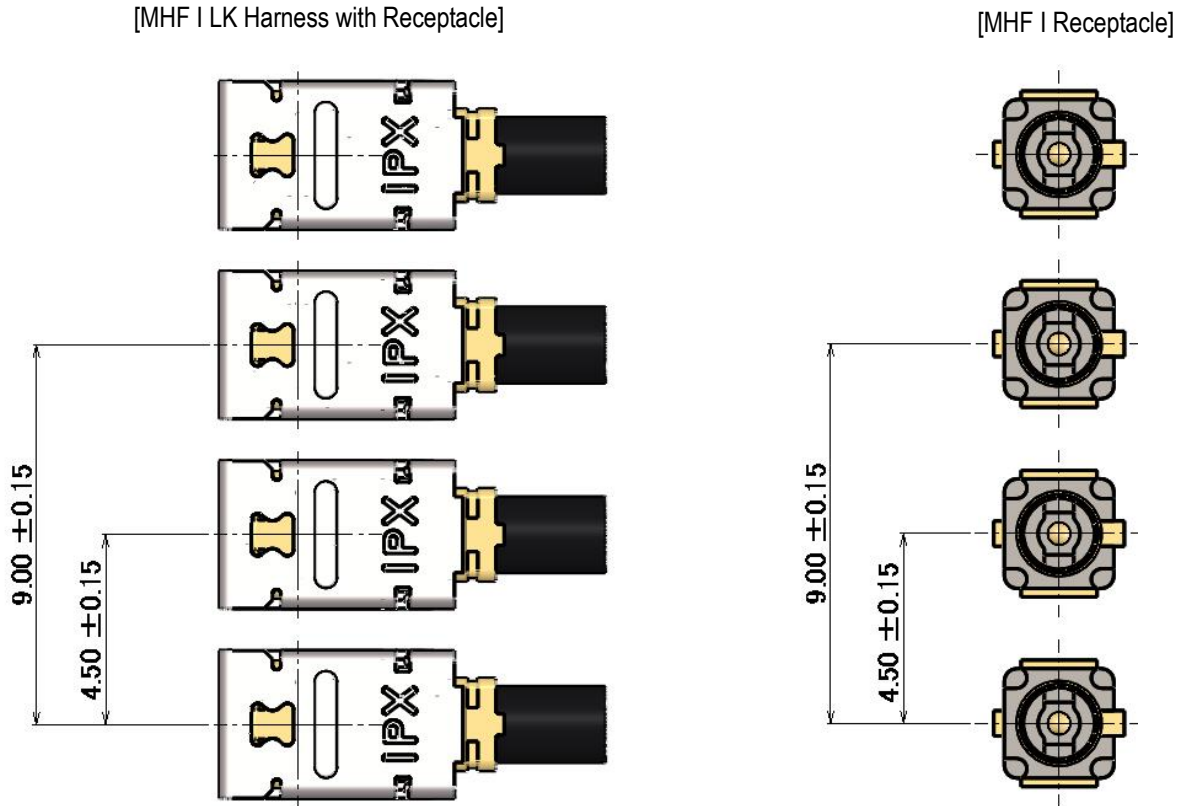

Figure 2

See page 5 and following pages for the detail instructions for the jig. The jig needs designated space for the operation. See Figure 28 and 29 on page 11 for the component placement prohibited area.

【Use Image of MHF I Receptacle Mounting on the Module Card】

The jig requires the component placement prohibited area as shown in Figure 4. See Figure 5 for a receptacle layout example.

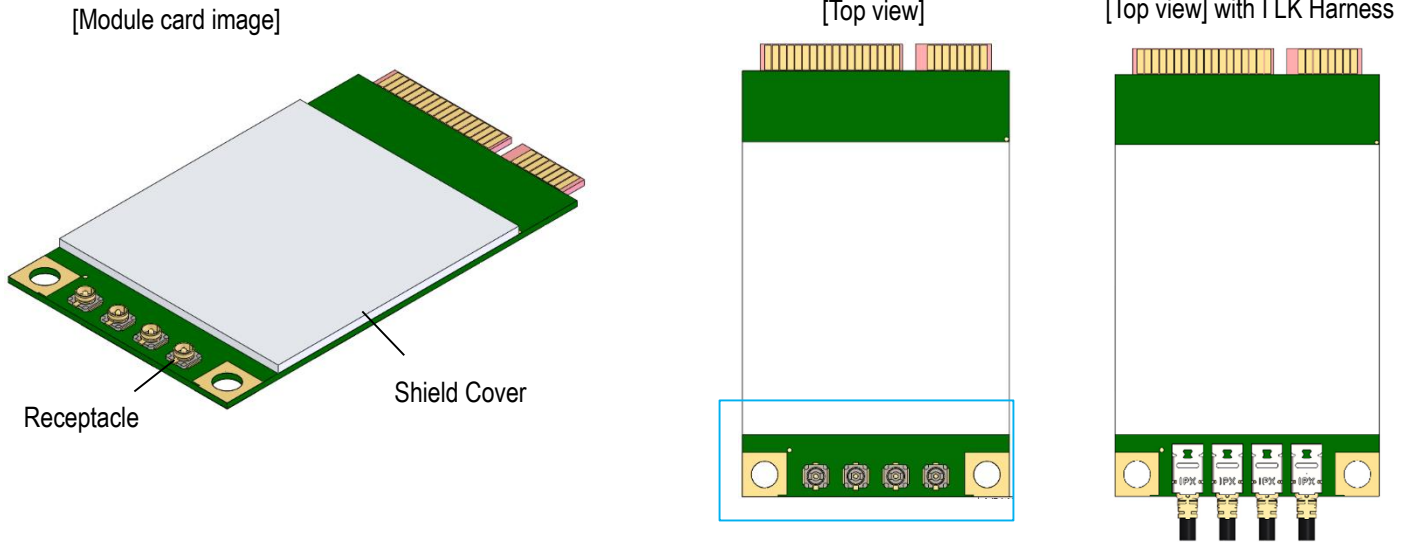

Figure 3

Figure 4 shows layout details and component placement prohibited area.

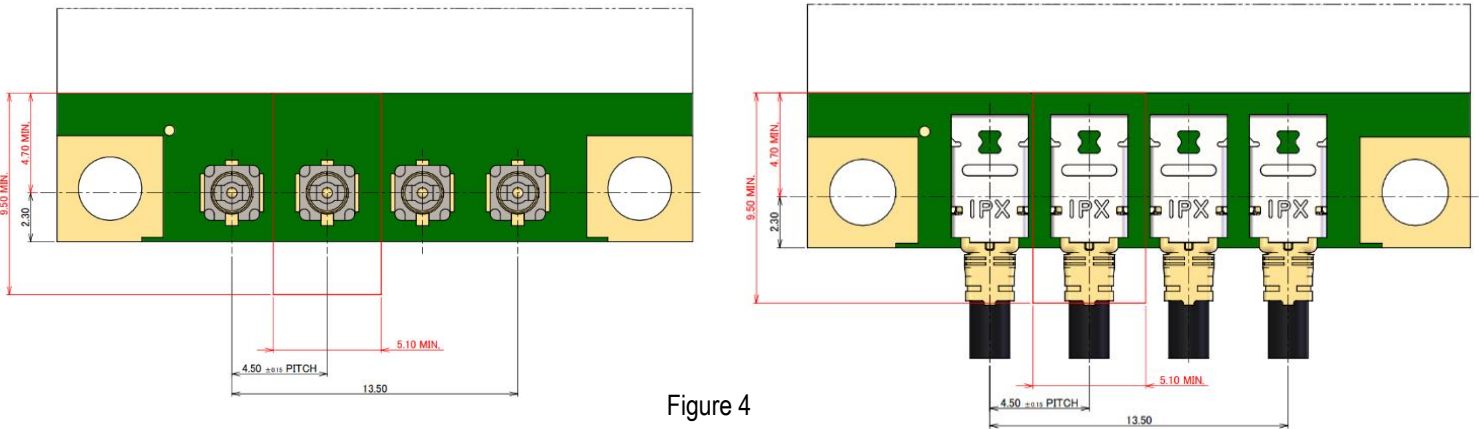
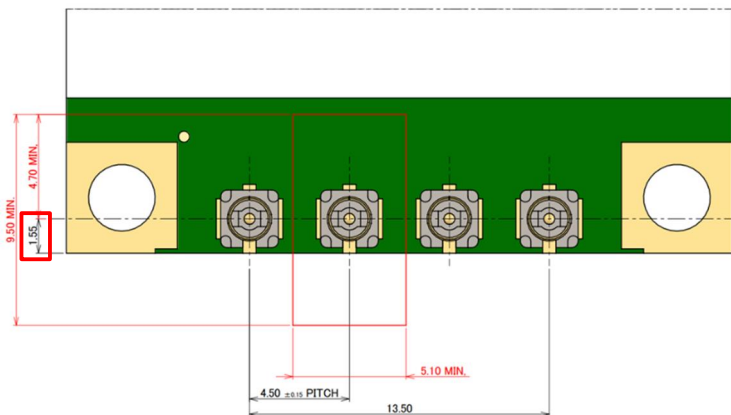

Figure 4



Placing receptacle close to the board edge provides a larger space for components such as the shield cover as shown in Figure 5.

Figure 5

CAUTION

- Do not place components including connectors and shield covers in the prohibited area.
- In the module PCB layout design, see MHF I Receptacle drawing and check the recommended footprint pattern for the appropriate connector placement.

【Recommended way of jig holding】

Marks indicated in Figure 6 are printed on the MHF I LK Hand Tool Jig sides to identify the holding area and for anti-slip purpose.

Hold the jig as covering these marks by fingers as shown in Figure 7.

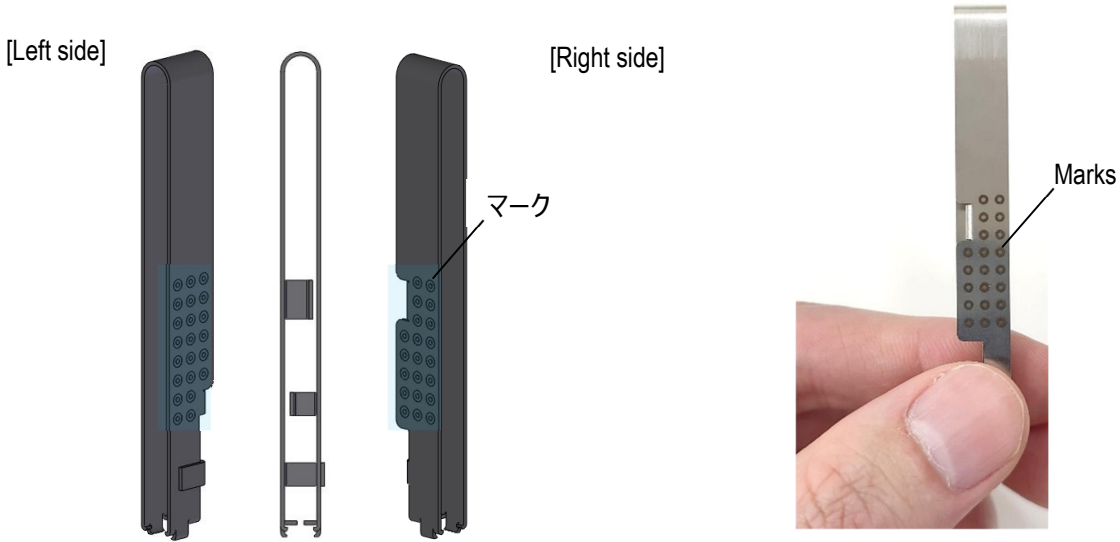
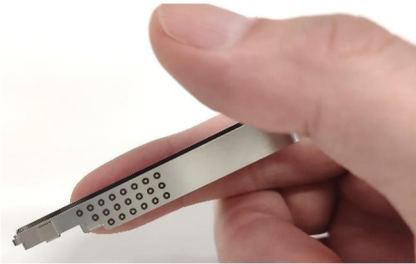

Figure 6

【Left side images】



【Holding image】



【Right side images】



Figure 7

CAUTION

Do not hold or apply the force the upper side of the jig as shown in Figure 8. The jig has deformation guards around the anti-slip marks. If the force is applied to the area without the guards, the jig may deform and break.

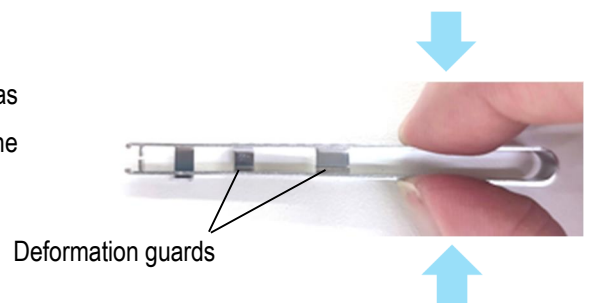

Figure 8

【MHF I LK Harness mating manual】

Procedures for mating by hands

① How to hold a MHF I LK Harness

Hold the end of cable as show in Figure 9.

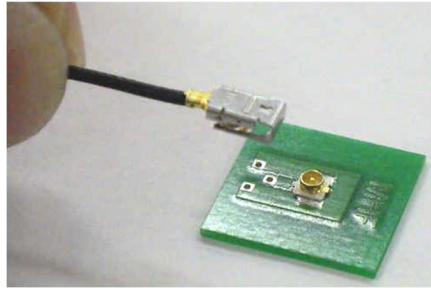

Figure 9

② How to align the MHF I LK Harness

Set receptacle of the PCB side and MHF I LK Harness as shown in Figure 10. Please check they are set firmly by moving back and forth slightly.

* Be sure that the locking function is unlocked.

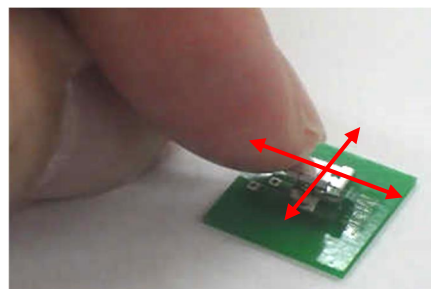

Figure 10

③ How to mate

Push the MHF I LK Harness center vertically as show in Figure 11. The connector clicks when completely mated.

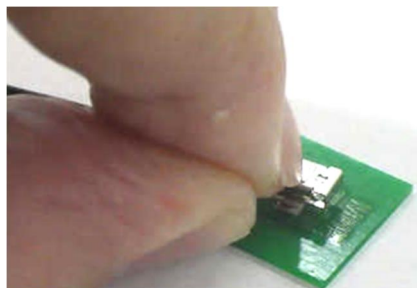

Figure 11

CAUTION

- Be sure to set the MHF I LK Harness parallel to the PCB and push vertically. Slant mating may cause the damage to the connectors.
- In the mating alignment, contact the MHF I LK Harness to the PCB connector lightly and move the MHF I LK Harness back, forth, right and left. Do not apply the insertion load before connectors are aligned.
- In mating, confirm the LK is unlocked. Mating the locked connector forcibly damages connectors seriously.

Proper MHF I LK Harness position (parallel to PCB)

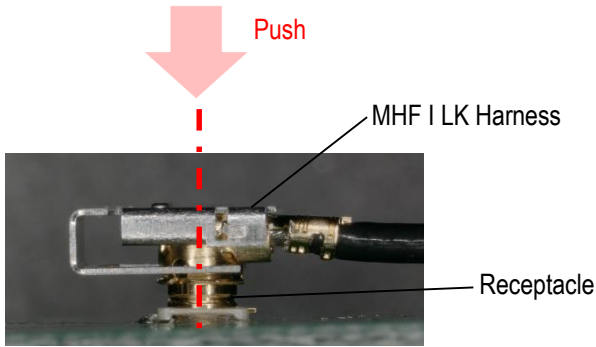

Figure 12

Improper MHF I LK Harness position (not parallel to PCB)

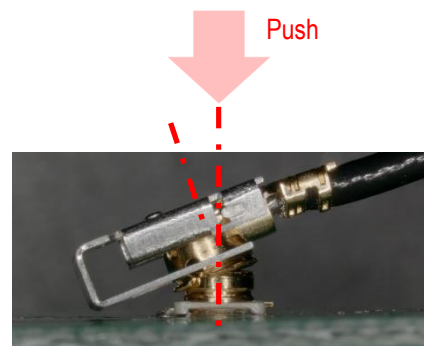

Figure 13

【How to lock the LK by hand】

- ① Set a finger on the surface indicated in a red box in Figure 22 and push the LK to the direction indicated in red arrow.
*LK clicks when completely locked.

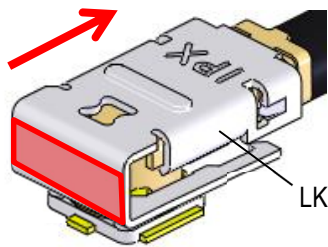

Fig. 14

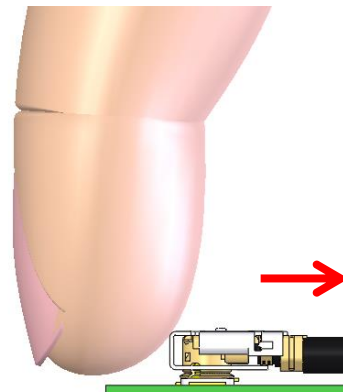

Fig. 15

【How to lock the LK with jig】

After mating connectors, slide the lock part to the direction indicated in Fig.16 by the jig.

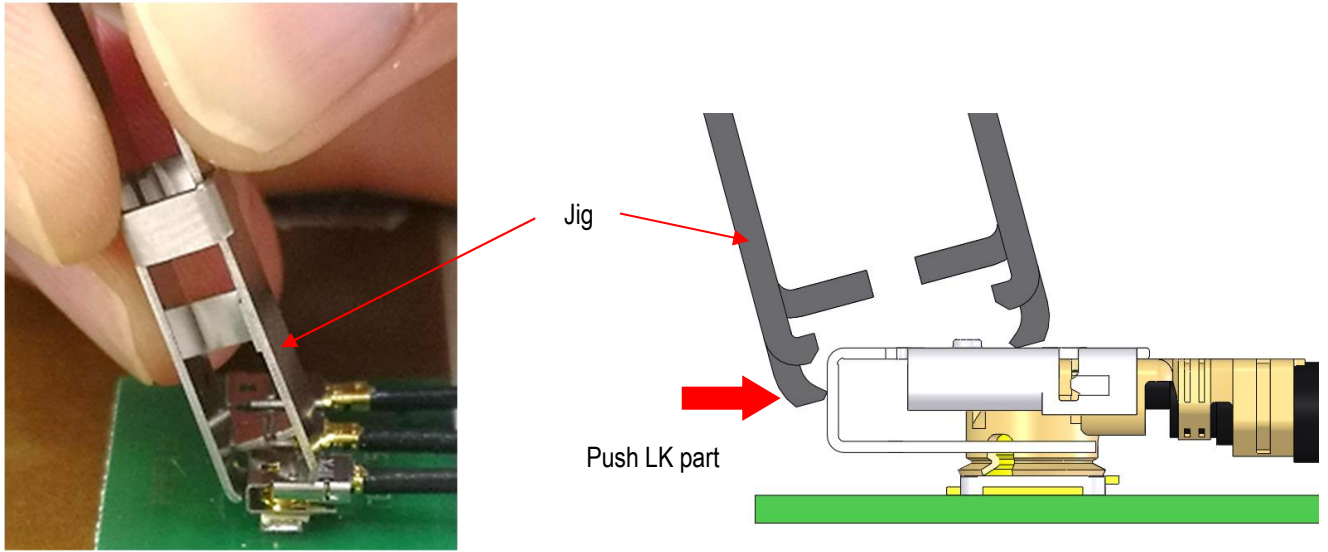

Fig. 16

CAUTION

- Slide the lock part until the connector passes the far edge of the hole at the lock part as shown in Fig. 17. Do not apply excessive force to slide the lock part.
- Halfway locking reduces the retention force.

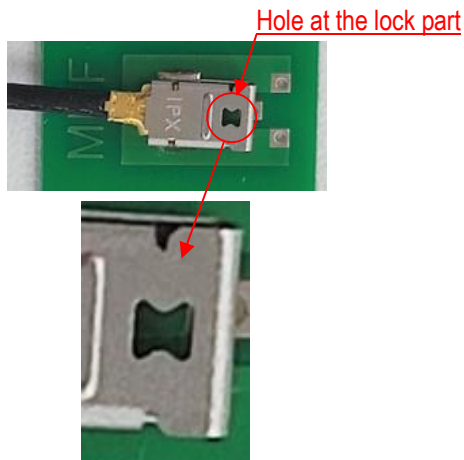

Fig.17 (Unlocked)

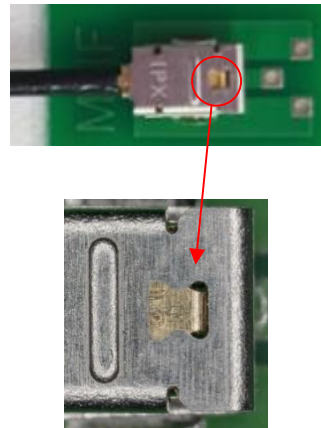

Fig.18 (Locked)

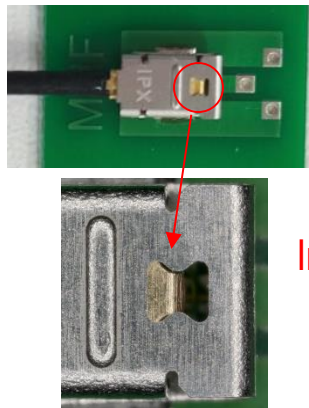

Fig.19 (Halfway locking)

Incomplete locking

【How to unlock the LK by hand】

Set a finger on the surface indicated in a red box in Figure 20 and slide the LK to the direction indicated in red arrow as shown in Figure 21.

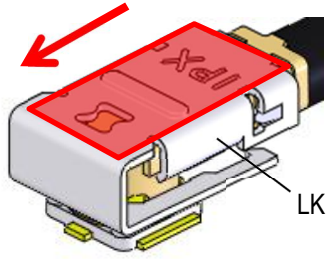

Fig. 20

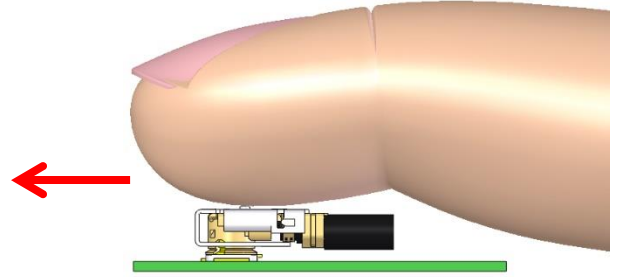

Fig.21

【How to unlock the LK with jig】

Set the jig from above the connector as shown Figure 22, and insert the jig tip to the LK designated area described in Figure 23.

Then, slide the jig to the direction described in Figure 24 to unlock. In unlocking, the operator feels a click when the LK is unlocked.

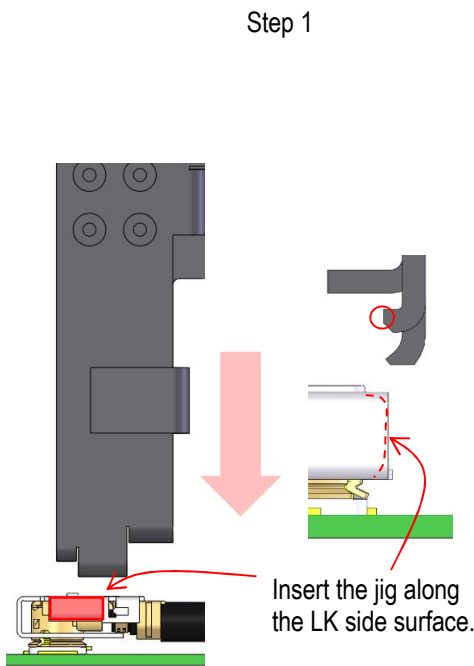

Fig.22

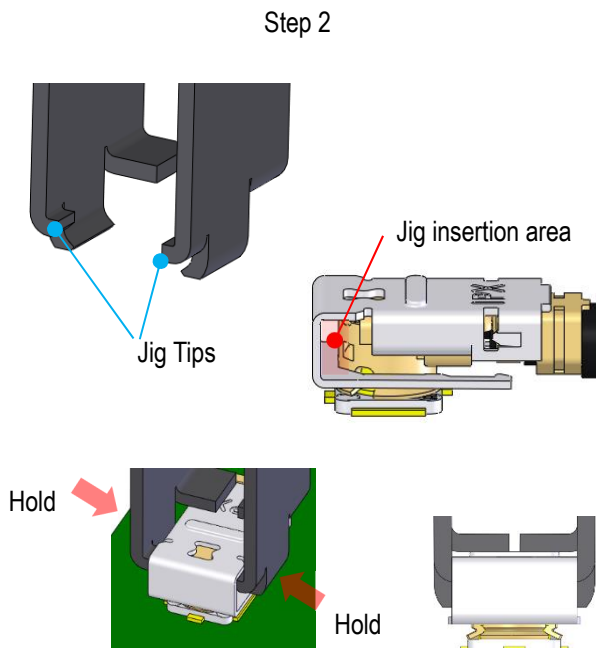

Fig.23

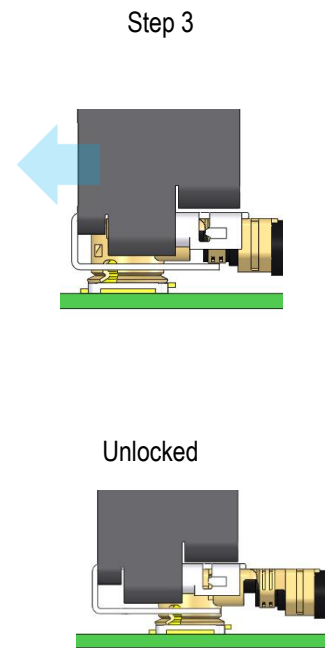

Fig.24

CAUTION

- In jig setting, insert the jig from above the connector to avoid interference with neighboring MHF I LK Harness.

【MHF I LK Harness unmating manual】

After unlocking completion, pull up the jig vertically to unmate MHF I LK Harness.

The operator cannot unmate MHF I LK Harness by hand. Please use the jig.

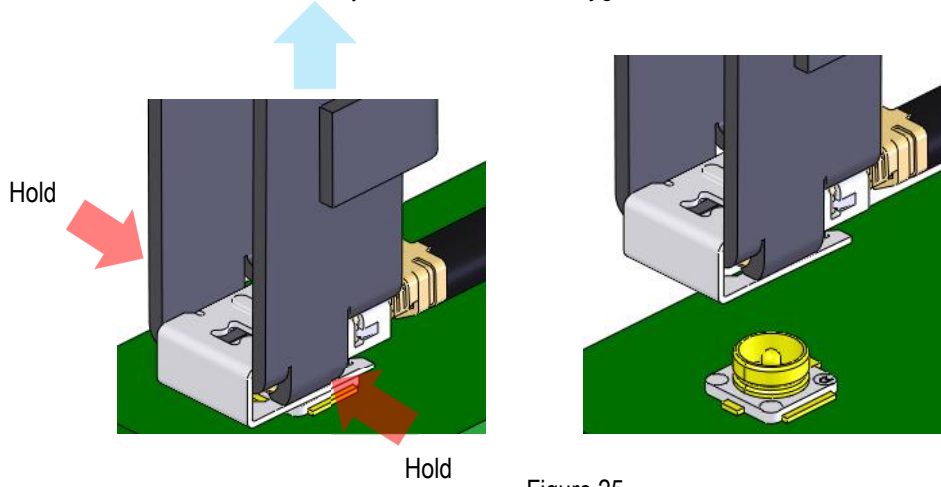

Figure 25

CAUTION

Jig must be raised vertically from the PCB surface.
Hold the jig tightly to unmate MHF I LK Harness.

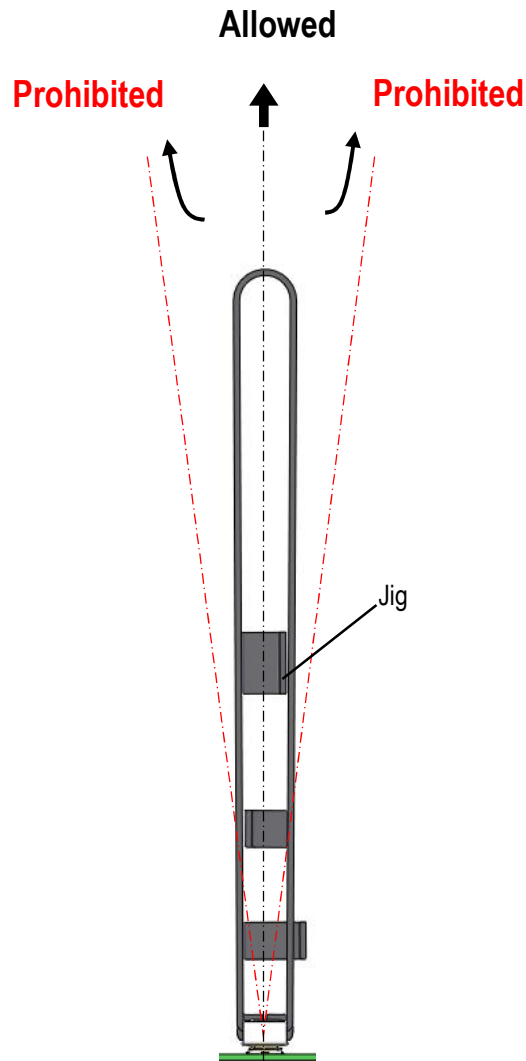

Figure 26

【Caution in MHF I LK Harness handling】

When the continuous force is applied in the way indicated in red arrows in Figure 27, MHF I LK Harness may be damaged and come off from receptacle connector. So please take care of handling of MHF I LK Harness.

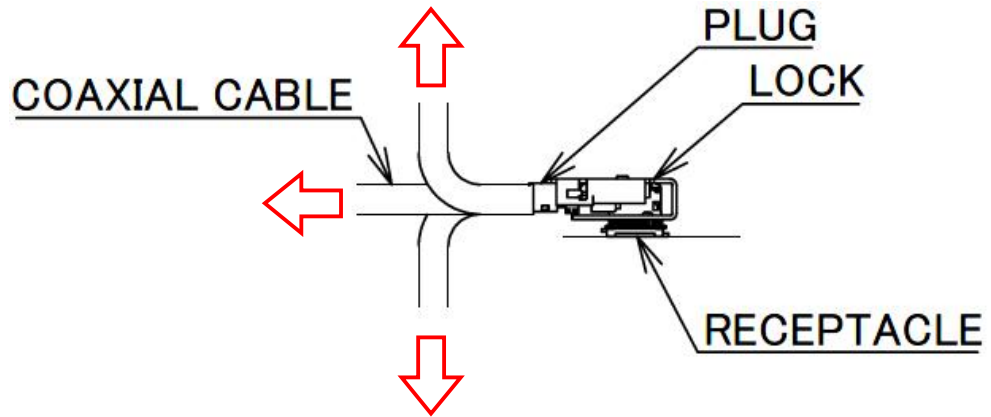

Figure 27

【Component placement prohibited area】

- Secure the space as shown in Figure 28 for the jig operation. Figure 29 is the layout of MHF I LK Harness in pitch 4.5 mm. The 4.5 ± 0.15 mm pitch layout enables jig access.

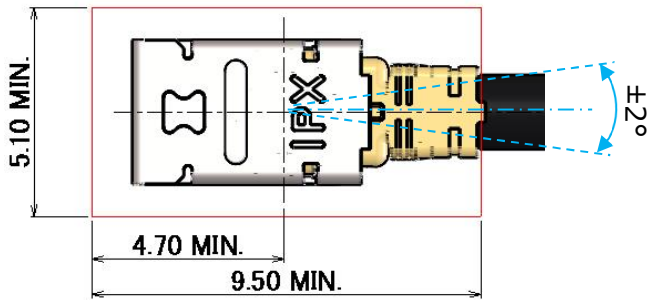

Figure 28

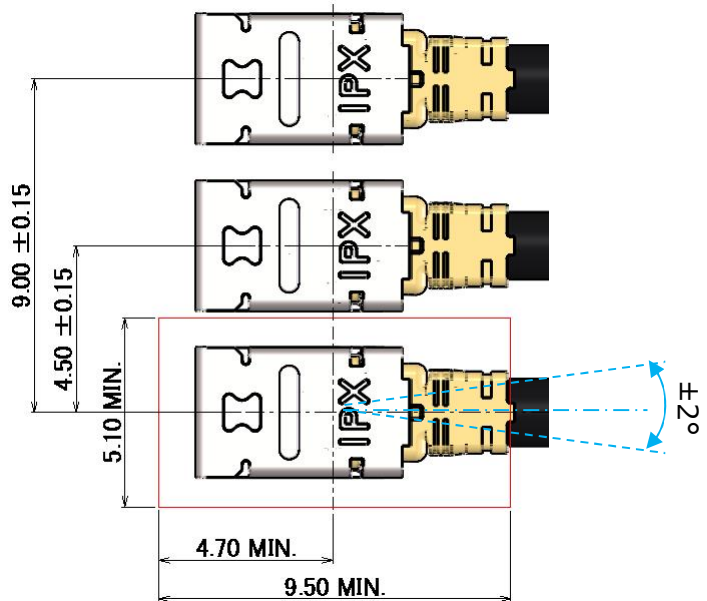

Figure 29

CAUTION

The applicable connector layout for MHF I LK Harness is 4.5 ± 0.15 mm. The jig cannot be used to MHF I LK Harness placed in smaller than 4.35 mm pitch.

In the jig use, the allowable rotation angle of MHF I LK Harness is $\pm 2^\circ$. When the jig is used for MHF I LK Harness which tilt exceeding $\pm 2^\circ$, the jig may hit the neighboring MHF I LK Harness and damage the connector.