

DW-5

【FOR MATING PLUG CABLE】

Part No. PLUG: 20598-0**T-02 RECEPTACLE: 20597-0**E-02

Instruction Manual

2	S24320	August 1, 2024	E.Tanaka	M.Muro	T.Masunaga
1	S17216	March 23, 2017	Y.O		TAK
0	S14232	June 13, 2014	Y.Fukumoto	K.Narita	T.Takano
Rev.	ECN	Date	Prepared by	Checked by	Approved by

This manual provides the insertion & withdrawal methods and cautions to handle DW-5 connector properly.

【 Connector Name, Part number】

◆The cable side connector

Product Name : DW-5 PLUG

Part No. : 20598-0**T-02

◆The PCB side connector

Product Name : DW-5 RECEPTACLE

Part No. : 20597-0**E-02

“ ** ” part shows the number of the connector position.

【Names of each part of the connector.】

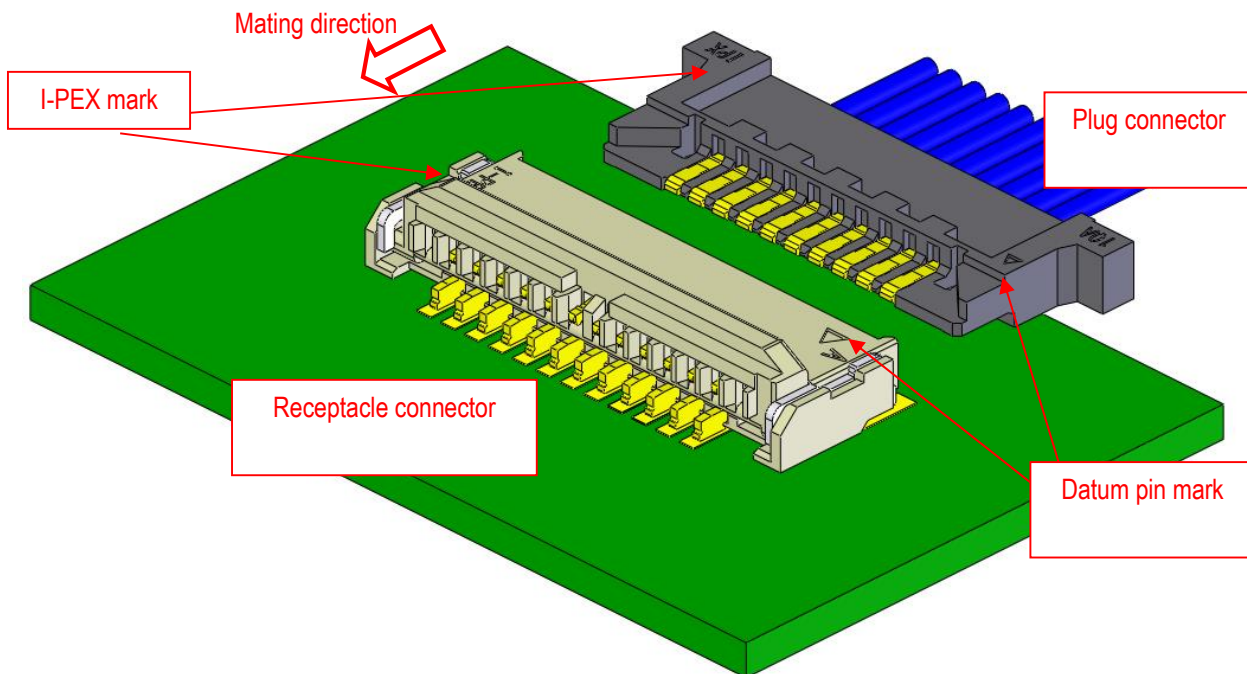

Fig.1

【 Connector Insertion Method】

- ① As shown in Fig.2, please set Plug connector on Receptacle connector.

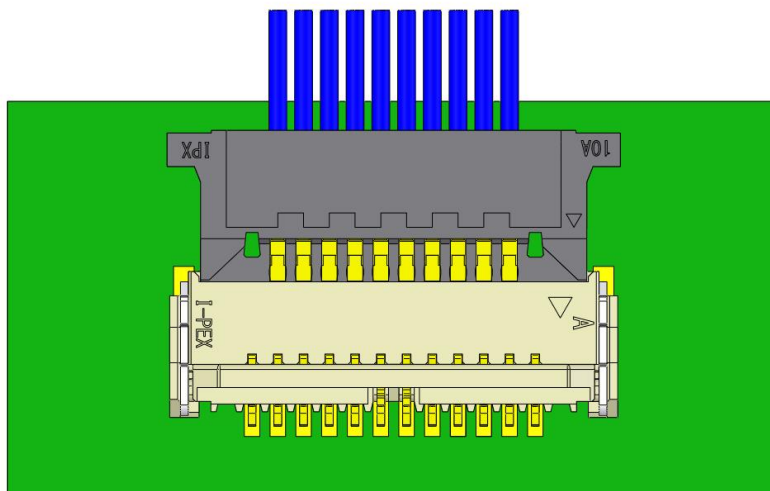
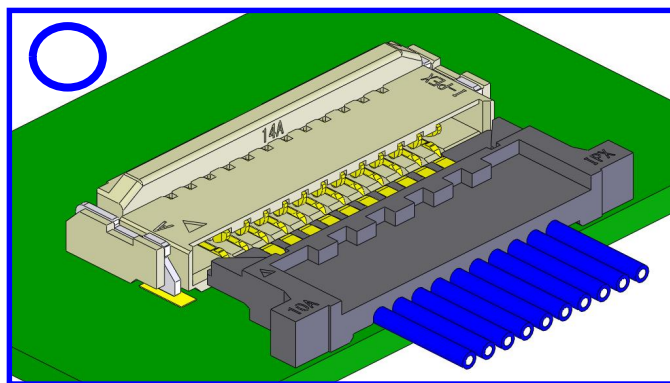

Fig.2

<Caution 1>

The correct mating figure of PLUG connector is below Fig.2(a), which wire connection part would be on the down side. Fig.2(b) would be incorrect mating, which wire connection part would be on the upper side.



(a) A correct side of the PLUG is mated

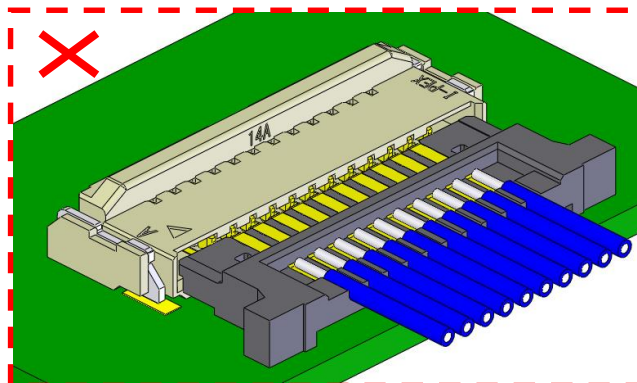

(b) A wrong side of the PLUG is mated

- ② Push both ends of Plug connector horizontally as shown in Fig.3.
When position relations of Plug connector and Receptacle become as shown in Fig.4 (a), mating is completion.

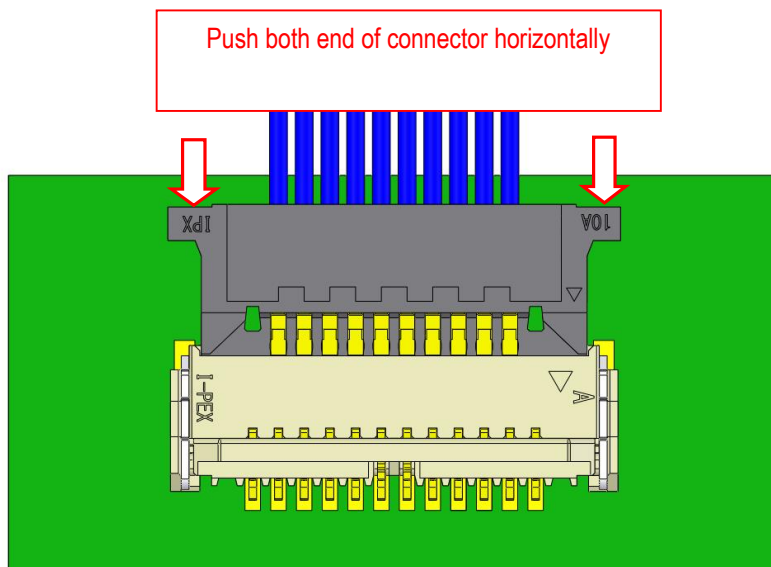
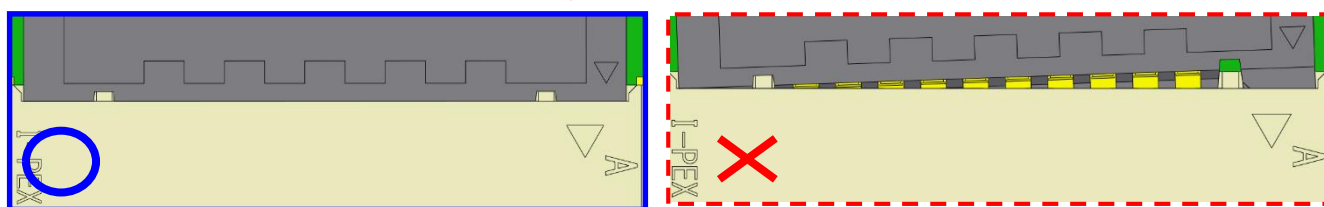
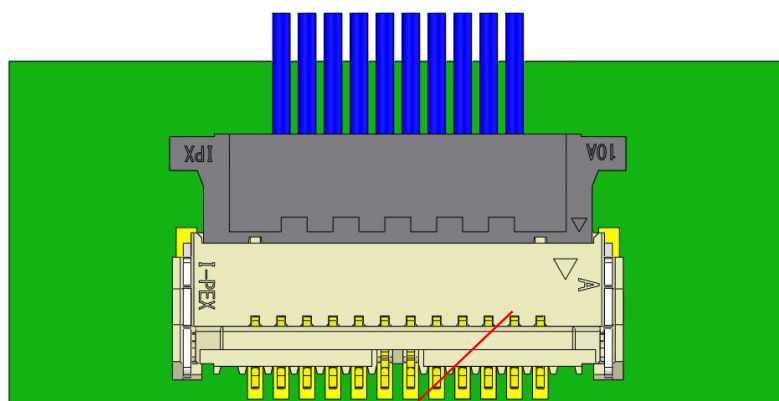

Fig.3



(a) State of complete mating

(b) State of incomplete mating

Fig.4

<Caution 2>

Please keep insert slant 5 ° or less in horizontal direction.
By inserting with the slant more than 5°, deformation of the connector will occur.

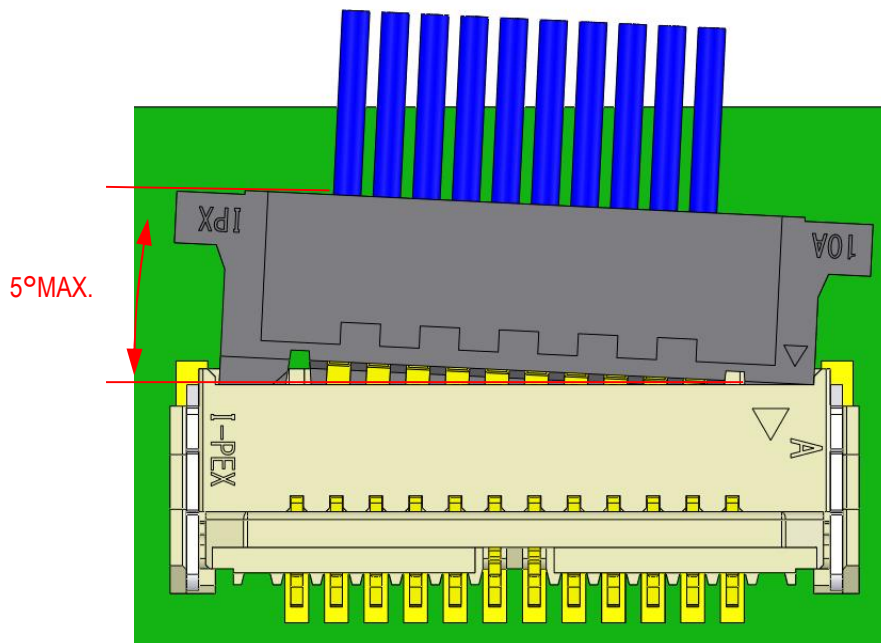

Fig.5

<Caution 3>

At starting the insertion, please keep the slant 5 ° or less in vertical direction.
By inserting with the slant more than 5°, deformation of the connector will occur.

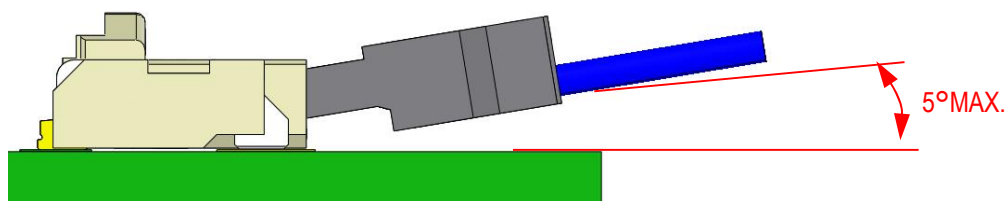

Fig.6

- ③ Push the center of actuator to the arrowed direction horizontally with finger cushion from the PLUG inserting direction.

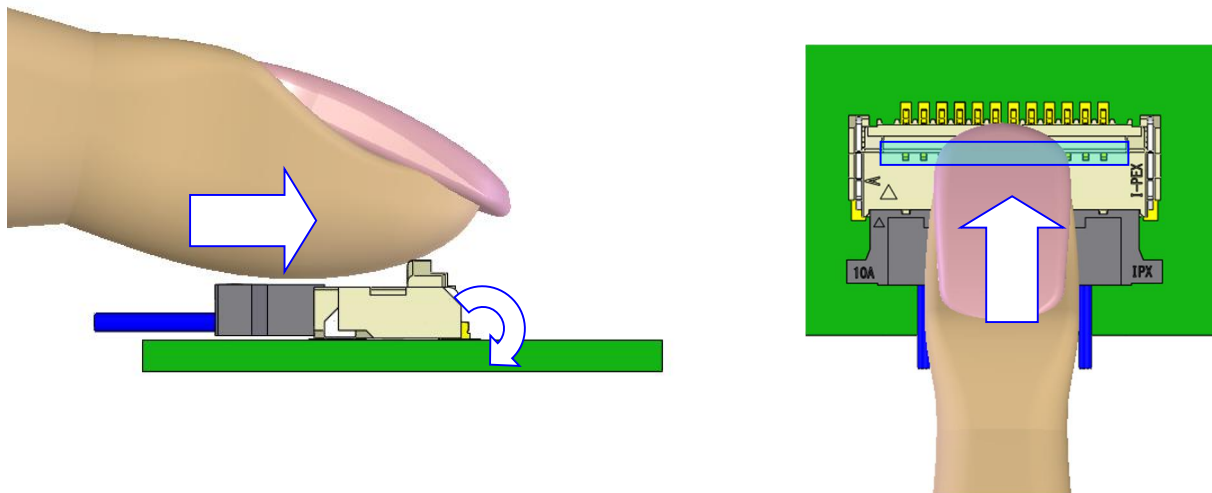

Fig.7 To lock actuator (OK)

<<Caution 4>>

- Please do not press an actuator from a top and lock actuator by finger nail. Actuator is damaged and a function is not satisfied.

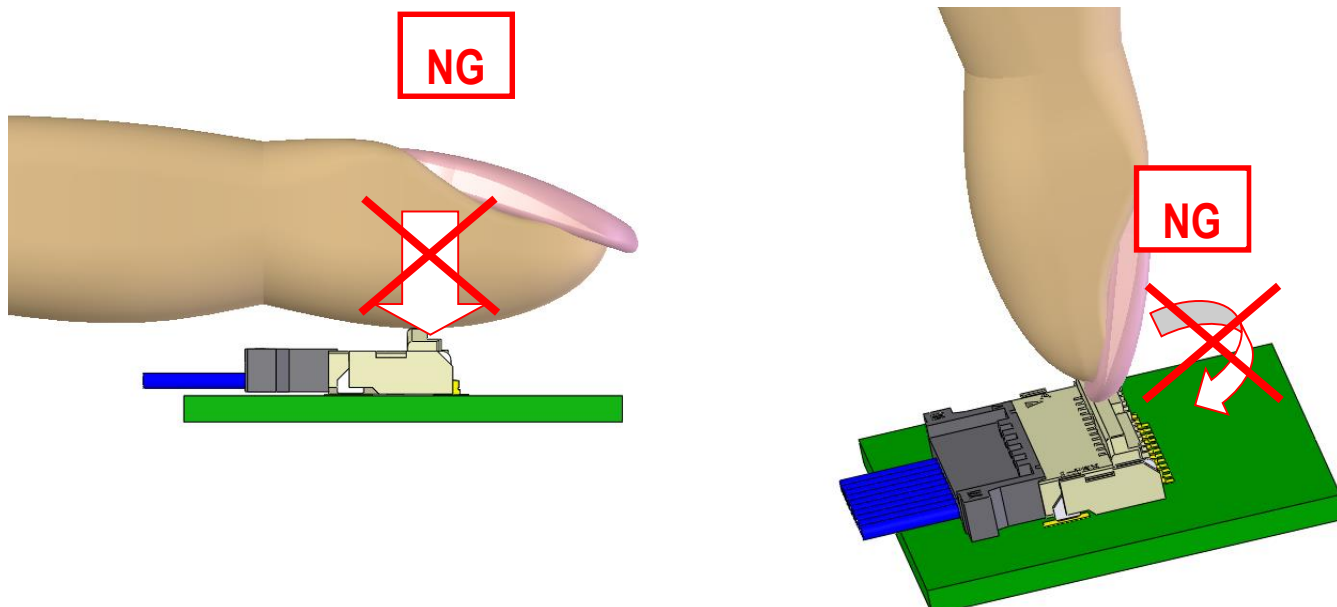

Fig.8 To lock actuator (NG)

- Please do not operate side of an actuator.
Actuator is damaged, or it becomes imperfect lock.

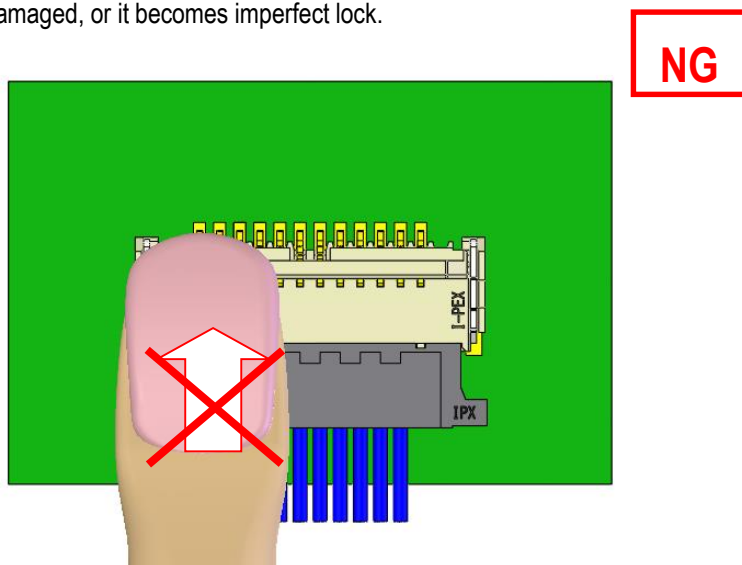

Fig.9 To lock actuator (NG)

- Please do not press at 10N or more housing on top and actuator after a lock actuator.
Connector and FPC are damaged. It becomes the electrical connection NG.

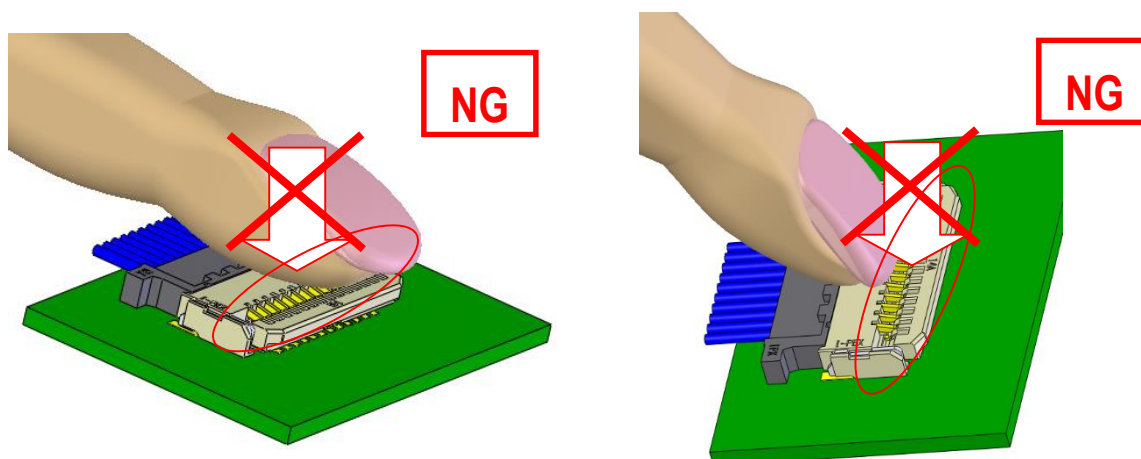

Fig.10 To lock actuator (NG)

- Please do not operate it using a sharp tool. (For example, tweezers) Connector is damaged.

【Connector Withdraw Method】

① To release actuator

Raise the center of actuator upwards lightly.

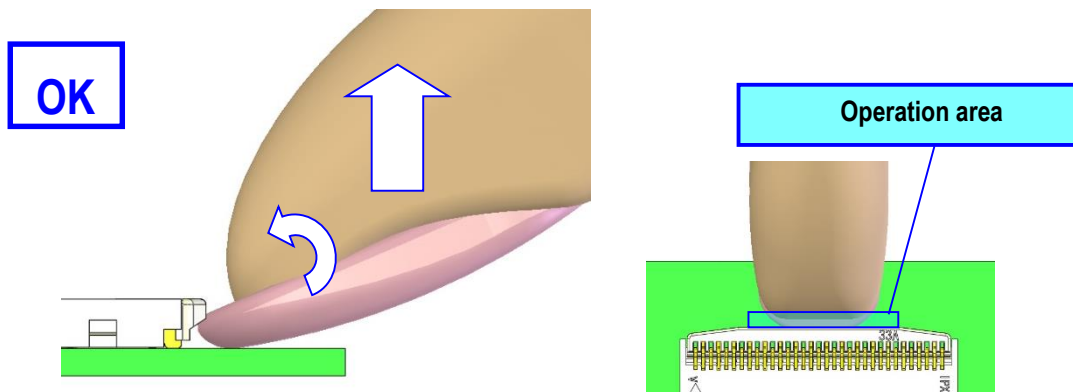

Fig.11 To release actuator (OK)

When release actuator is difficult, raise the center of actuator upwards lightly using the following JIG.

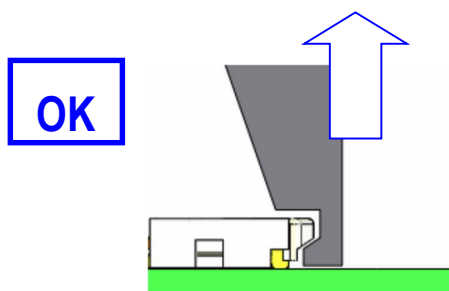

Fig.12 To release actuator (OK)

<<Caution 5>>

- Please do not press to the direction of FPC mating side.
Actuator and contacts are damaged.

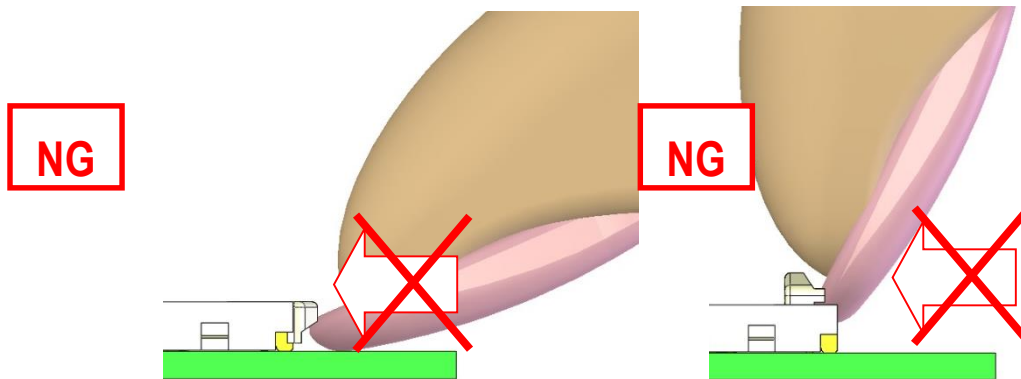

Fig.13 To release actuator (NG)

- Please do not operate side of an actuator. Actuator is damaged.

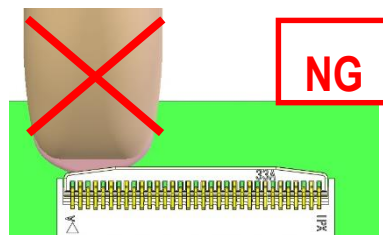

Fig.14 To lock actuator (NG)

- Please do not operate it using a sharp tool. (For example, tweezers) Connector is damaged.

- ② Pull the both ends of the pull bar which put up perpendicularly parallel to a board as shown in Fig.13.

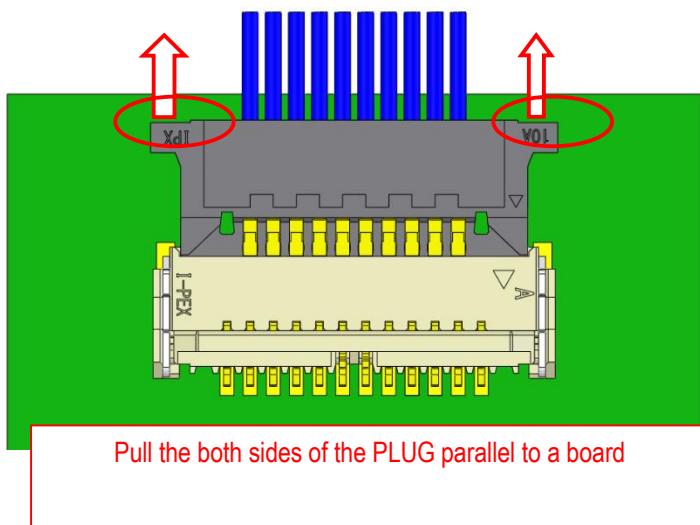

Fig.15 To withdraw PLUG (NG)

<Caution 6>

Please keep withdrawal slant 5° or less in horizontal direction.
By withdrawing with the slant more than 5° , deformation of the connector will occur.

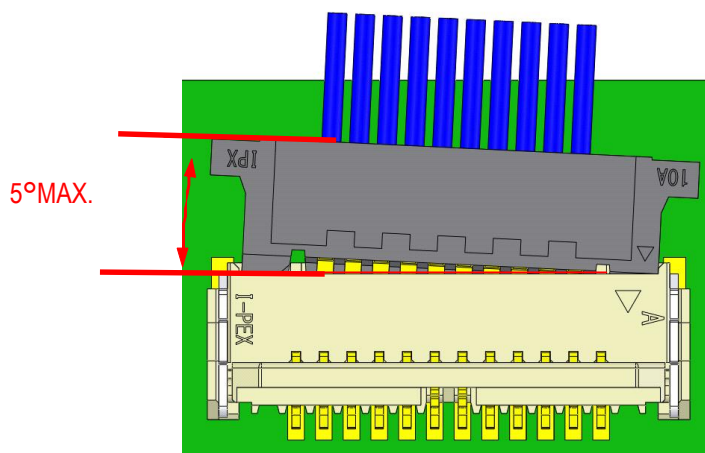

Fig.16

<Caution 7>

Please do not withdraw the connector by pulling the cable.
There is possibility to beak the cable.

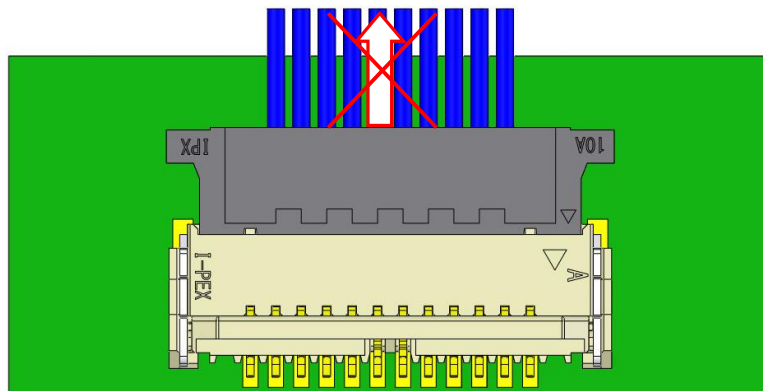

Fig.17

In handling the cable, please pay attention not to apply excessive force to the connector or the cable.
It may cause the connector or the cable breakage.

Continuous stress to the connector should not remain after assembly.
It may cause the mating defect or the connector breakage.

<<Caution 8>>

Please refrain from withdrawing PLUG with actuator close condition. It may cause deformation of PLUG.

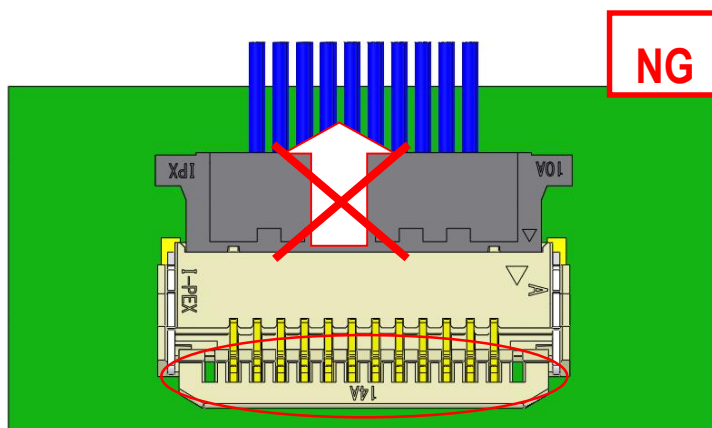

Fig.18 To withdraw PLUG (NG)

※If PLUG receives damage, PLUG retention force will be down, please exchange to new PLUG.