

CABLINE®-UM

Part No.Plug:20877-#**T-※※ / 21074-0**T-01

Receptacle:20879-#**E-※※ / 21076-0**E-01

Instruction Manual

16	S25063	January 31, 2025	K.Tanabe	M.Nakamura	T.Masunaga
15	S25051	January 28, 2025	K.Tanabe	M.Nakamura	T.Masunaga
14	S25032	January 15, 2025	T.Ono	M.Nakamura	T.Masunaga
13	S24069	February 13, 2024	H.Uchida	M.Nakamura	T.Masunaga
Rev.	ECN	Date	Prepared by	Checked by	Approved by

This manual is to explain the insertion & withdrawal methods and important points in handling of CABLINE-UM connector plug with cable for the purpose of proper use.

[Connector Name, Part number]

◆The cable side connector

Product Name : CABLINE-UM Plug

Part No. : 20877-#**T-※※ / 21074-0**T-01

◆The PCB side connector

Product Name : CABLINE-UM Receptacle

Part No. : 20879-#**E-※※ / 21076-0**E-01

“ ** ” part shows the number of the connector position.

“ ※ ” part shows the variation. Please refer to the drawing for details.

[Names of each part of the connector.]

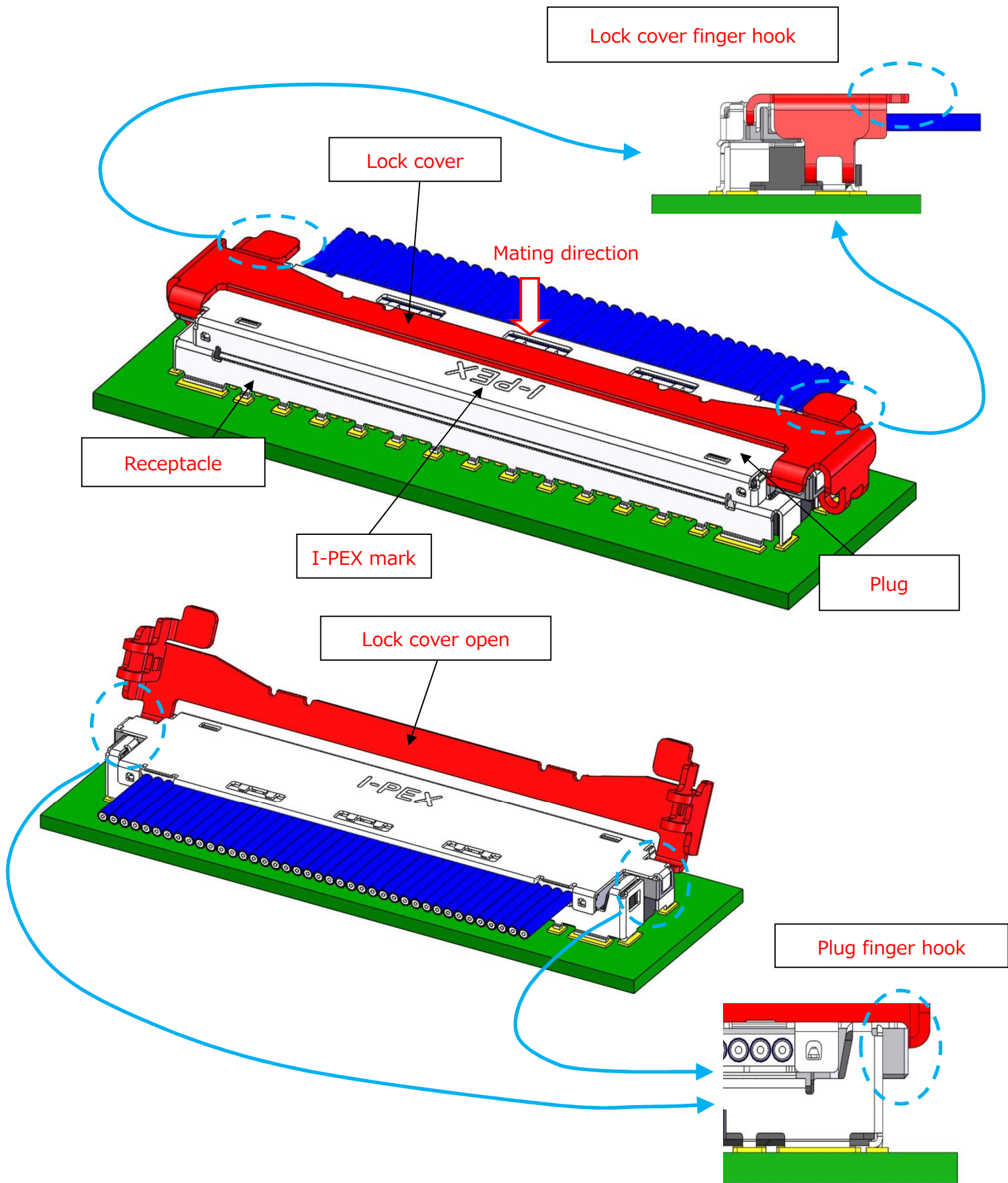

[Comparing Plug parts numbers]

20877-#E-※1**
21074-0E-01**
With Lock Cover

20877-#E-※2**
Without Lock Cover

20877-#E-※3**
With PULL TAPE HOLDER

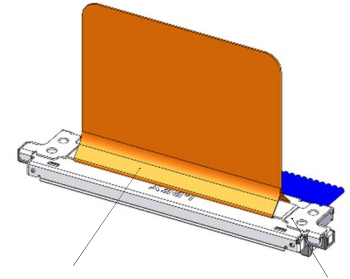
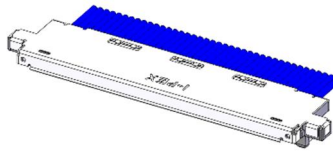
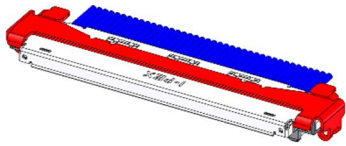

PULL TAPE PULL TAPE HOLDER

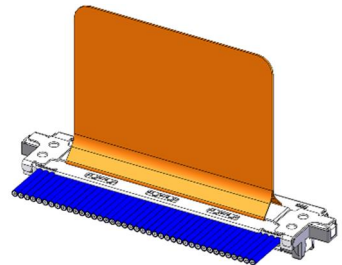
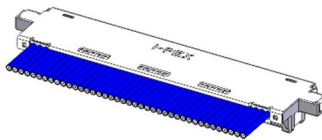
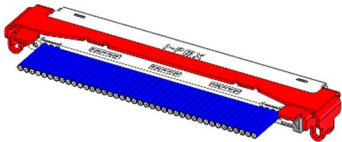

[Comparing Receptacle parts numbers]

20879-#E-※1**
21076-0E-01**
Shell Soldering Area

Refer to red dotted box below.

20879-#E-※2**
Shell Soldering Area

Refer to blue dotted box below.

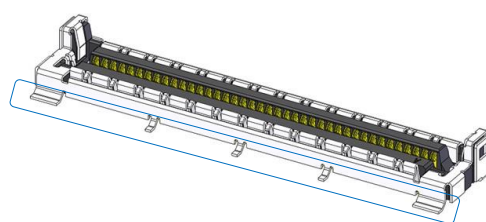
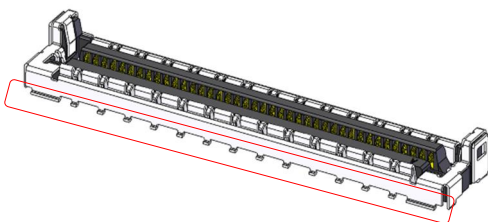
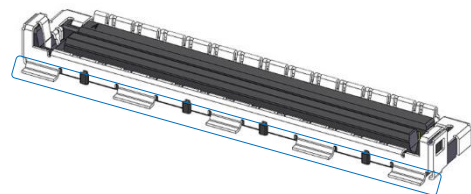
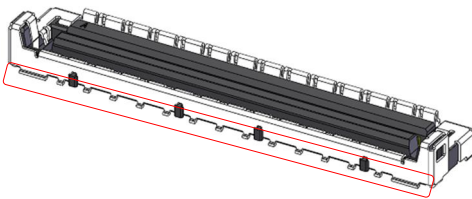

[Connector Insertion Manual]

1. Which direction to mate

As shown in Fig.1, make sure to place a cable on non-soldered tail side.

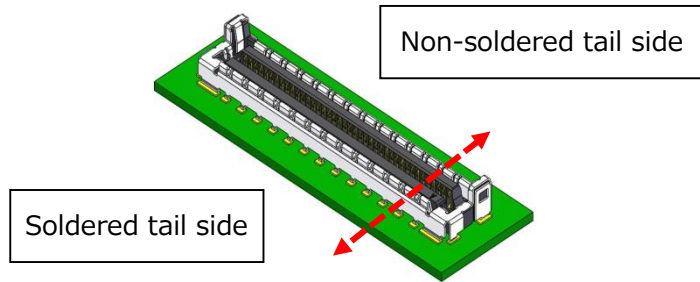

Fig.1

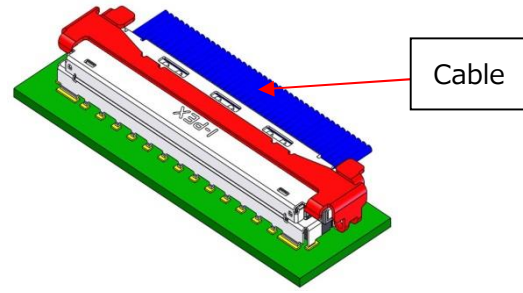

Fig.2 Correct Connector Mating View

CAUTION

Do not mate the connector while cable is at soldered tail side.

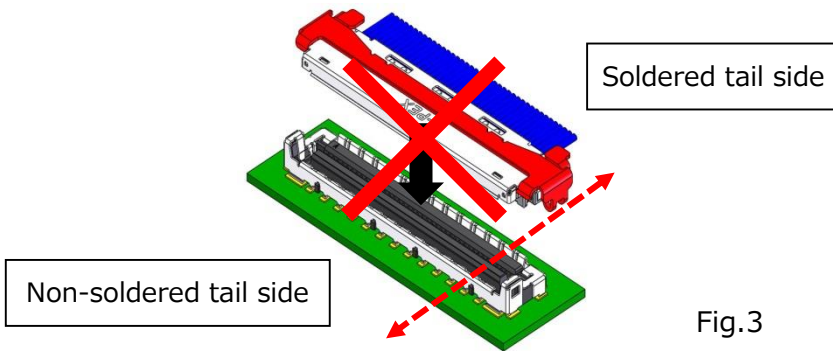
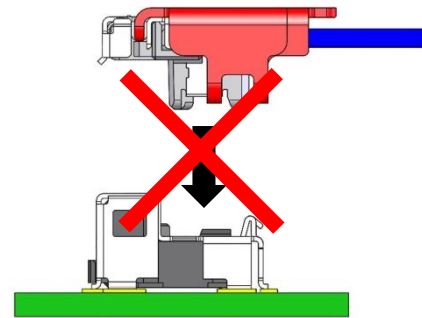

Fig.3



•As shown in Fig.4 and 5, Please set it so that both ends of PLUG are located within the "[]" of silk print on PCB.

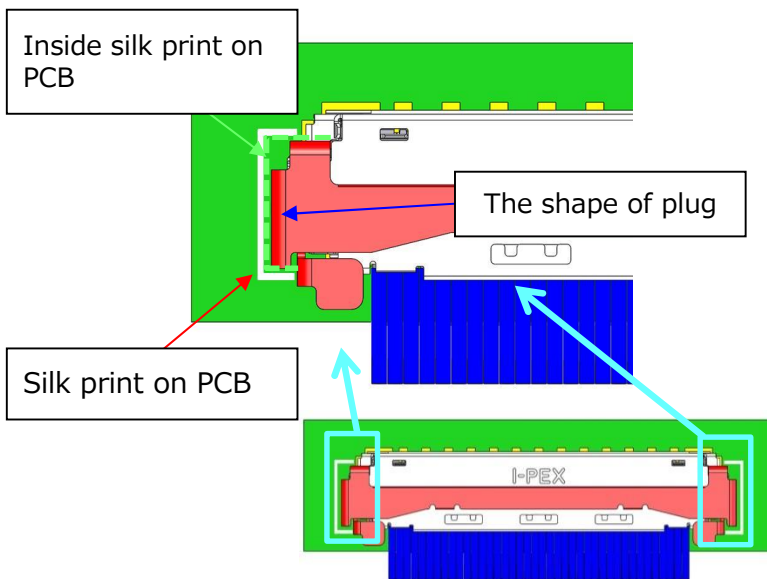

Fig.4 With Lock cover

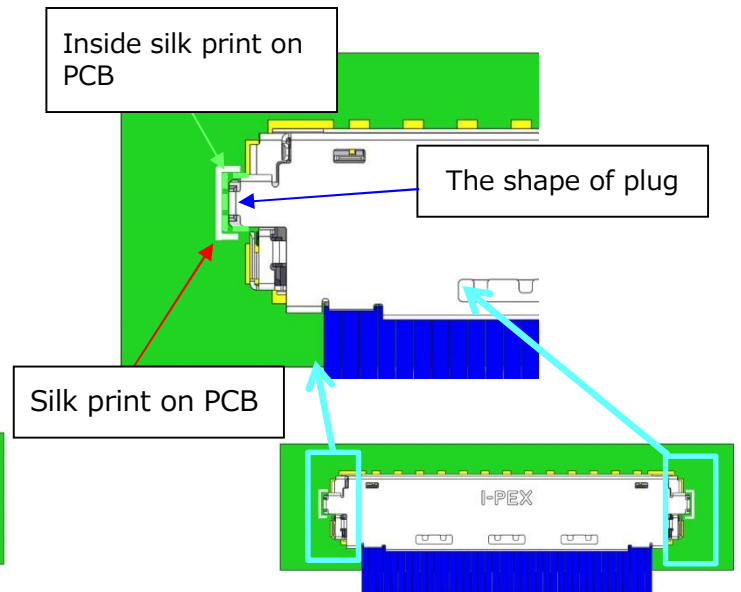

Fig.5 Without Lock cover

·Always close lock cover before mating plug or it may deform lock cover which will decrease locking strength.

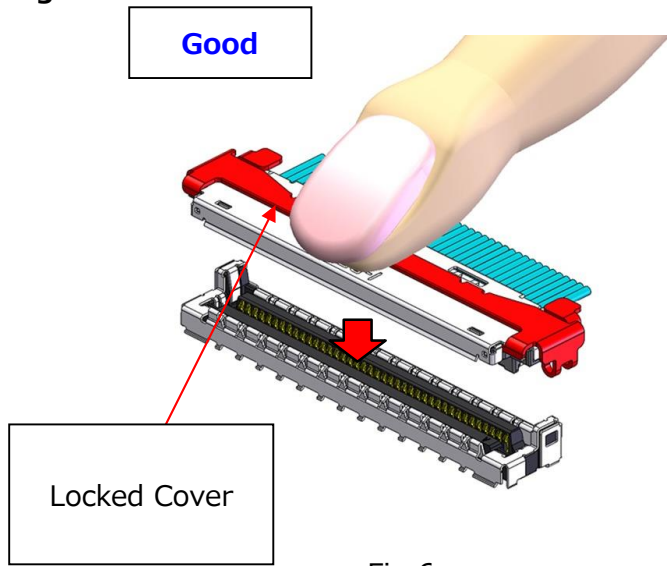

Fig.6

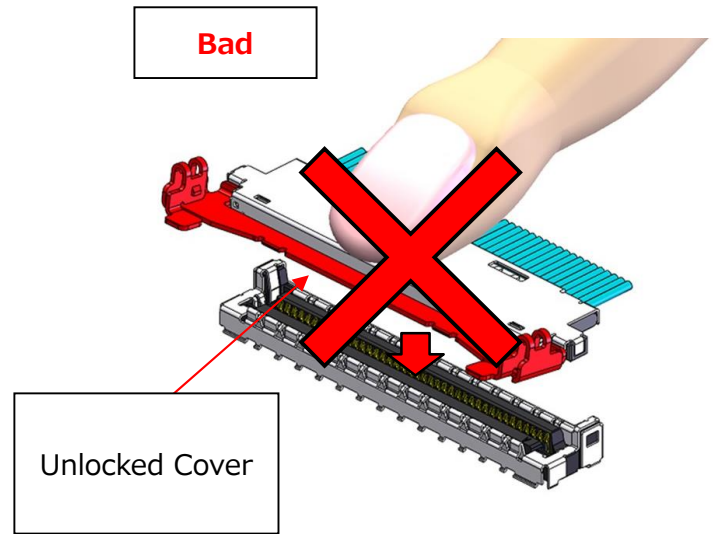

Fig.7

2. Pre-insert the cable connector into the receptacle connector.

The insertion angle in the height direction is within 12° as shown in Fig.8.

After that, Pre-insert until the plug connector is parallel to the receptacle connector.

CAUTION

- A support shall be designed and placed under PCB in order to prevent PCB from being deformed when cable connector is inserted with a pressing.
- The initial connector insertion angle allowance is given in Fig.8. Please set so that it becomes parallel without applying excessive force afterwards. Do not force to press cable connector when the insertion angle is out of this allowance angle.
- Do not mate the connector at an angle that exceeds the allowable angle or is out of the normal position. Connector damage may occur.

Note 1. One side mating: Receptacle and plug mating slot side wall are touched on one end

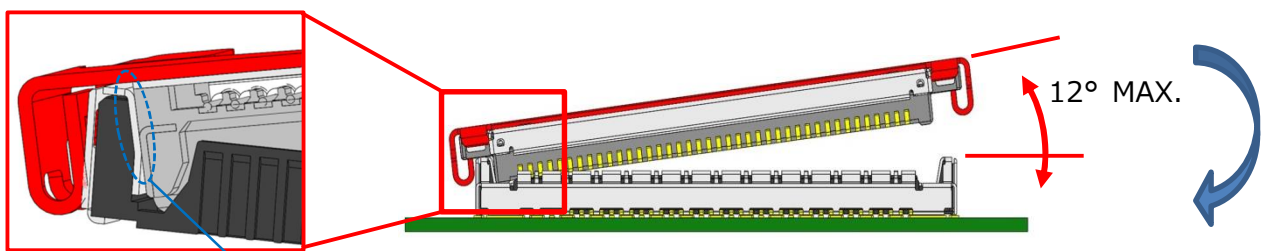

One side mating Note 1

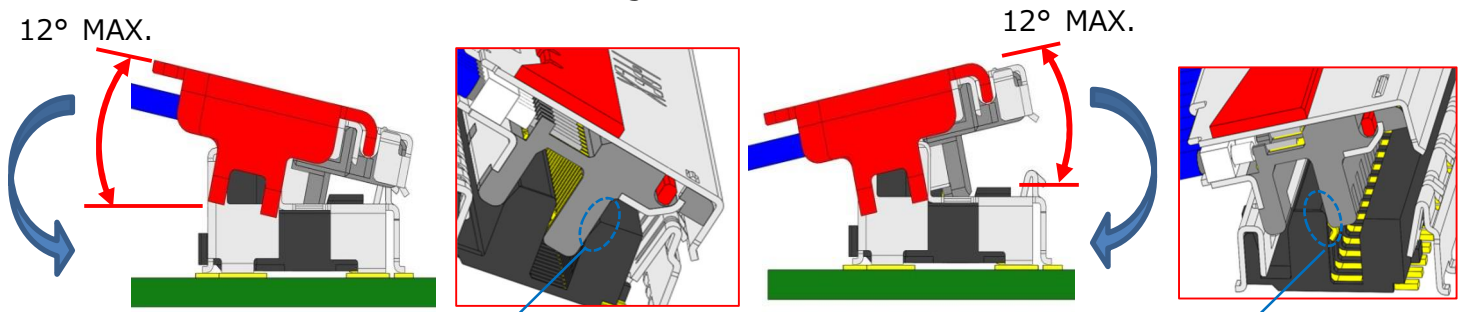

One side mating Note 1

One side mating Note 1

Fig.8 Insertion angle allowance

CAUTION

•If Pre-insert is NG, repeat step 2.

3. How to Mate

Push the center of cable connector vertically until it clicks.

The clicking shows the mating completion. [Fig. 9]

Push both ends of the connector to make sure the mating is completed. [Fig. 10]

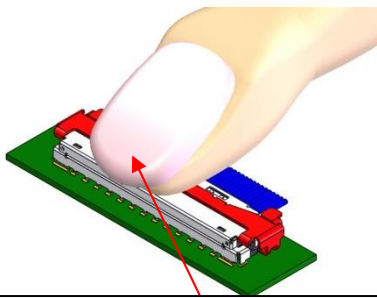

Push the center of connector

Fig.9

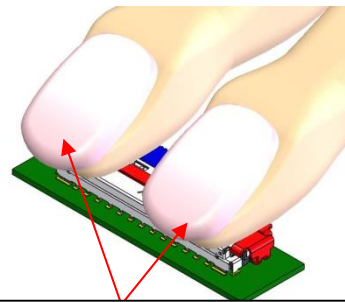

Then push both connector ends and check the mating condition to ensure that either end is securely inserted.

Fig.10

CAUTION

•If the connector is not locked on both sides, it may fall off.

【How to Withdraw Cable Connector by finger】

- ① Lift a lock cover finger hook outward on one end and repeat it again on opposite side to release lock cover. Make sure that the inner lock part is completely released. (see Fig.11)

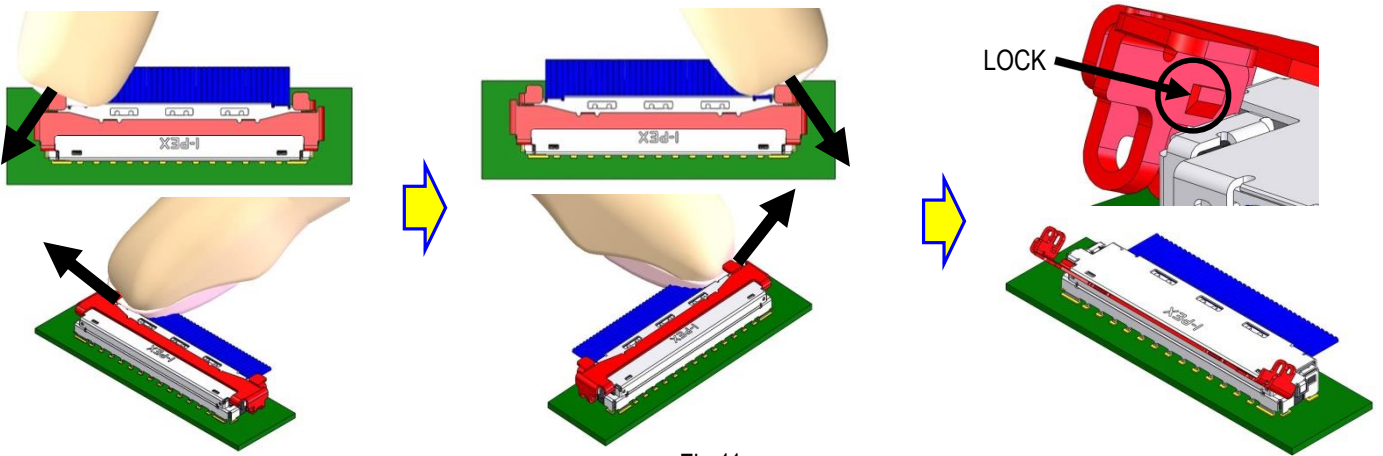
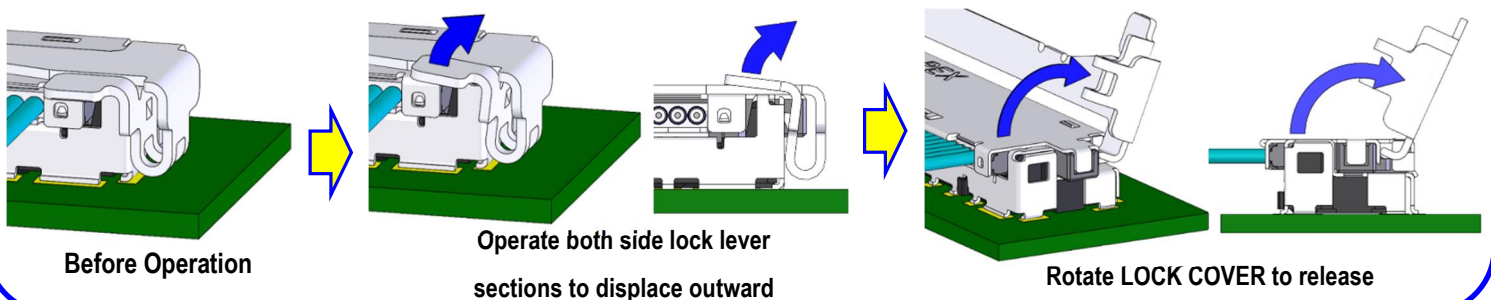

Fig.11

CAUTION

•When releasing the lock, operate the lever part so that it is displaced outward from the center of the product. Pulling up vertically near the lever section or forcibly pulling it up by pushing it into the anti-cable side will destroy the lock and cause a reduction in locking force.

Good operation



Bad operating procedure

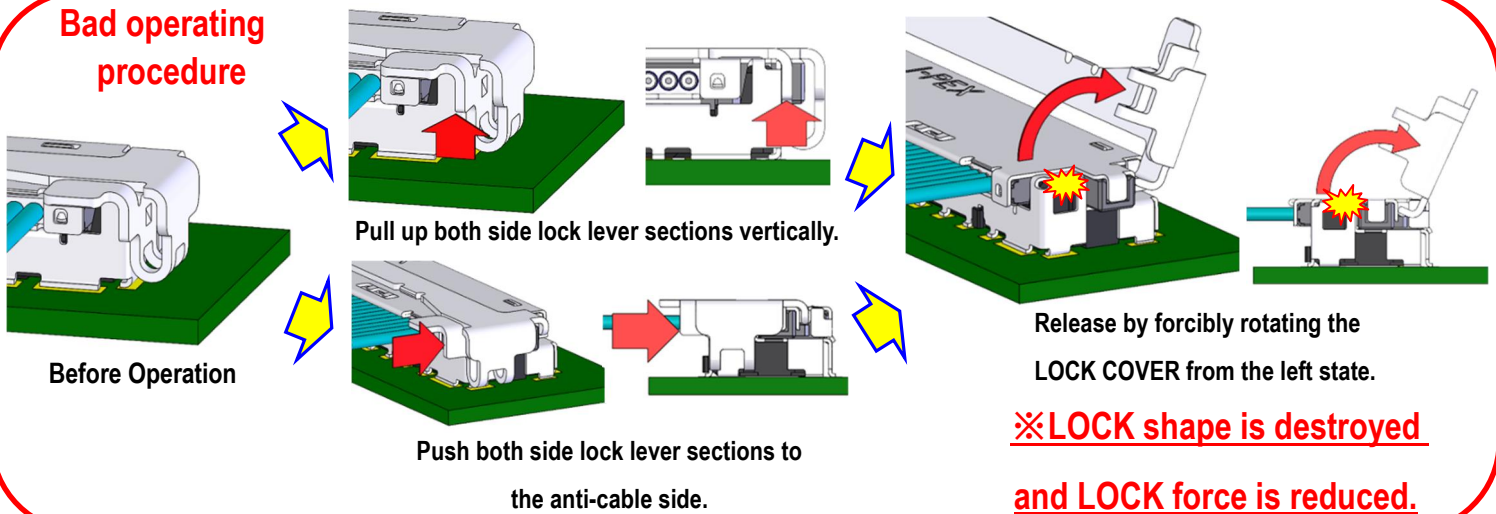

Fig.12

② TYPE 1

Hook both ends of the Plug with the nail and withdraw the connector. (see Fig.13)

TYPE 2

Jump up both ends of the plug one by one and withdraw the connector. (see Fig.14)

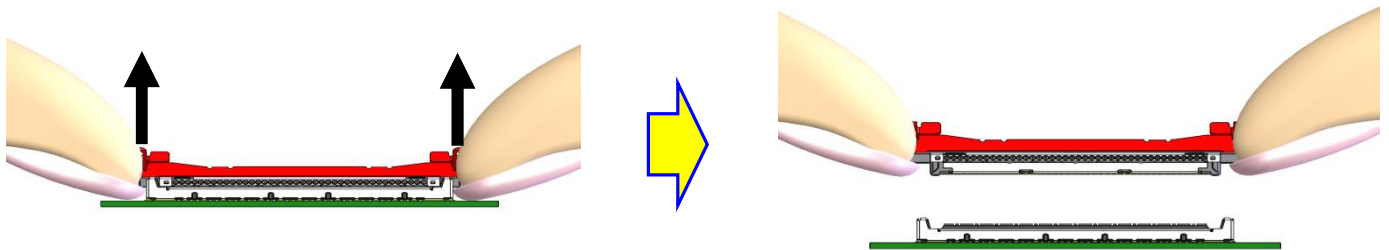

Fig.13 TYPE 1

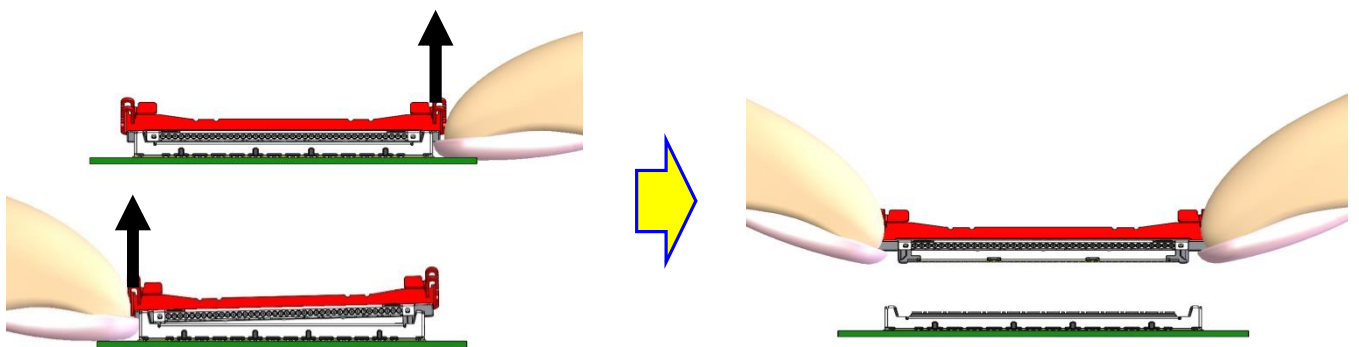

Fig.14 TYPE 2

[How to Withdraw Cable Connector by Unlock jig & Pull jig]

- ① Guide the Unlock jig to both side of the LOCK COVER as shown in Fig. 15-1, and set the JIG actuator at the bottom of the LOCK lever.
- ② If Unlock jig set is OK, pull up on Unlock jig to release the Lock

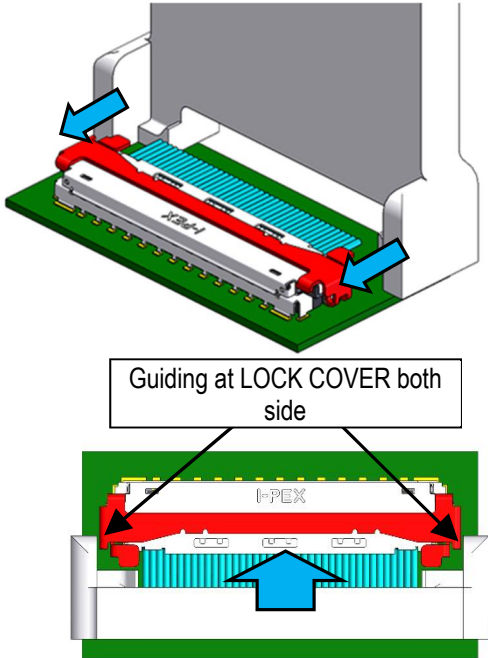

Fig.15-1

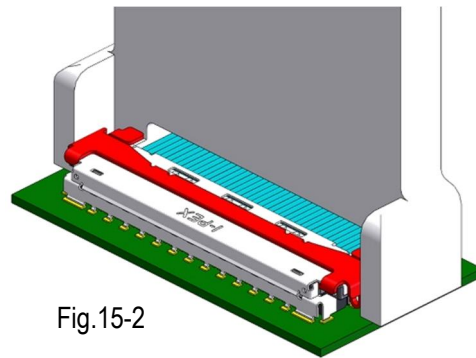
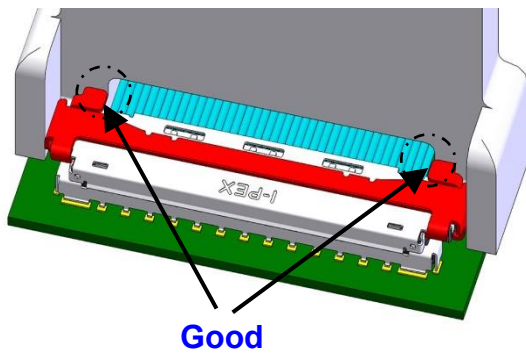

Fig.15-2

Set the JIG into the connector so that the LOCK operating shape of the JIG enters under the LOCK lever.

(See Good condition)

If a Bad condition is encountered, start the process over from the condition shown in Fig. 15-1.



Good

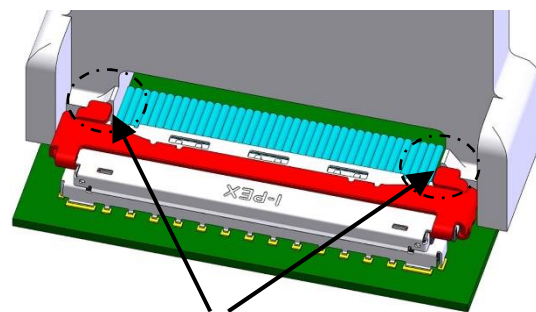

Bad

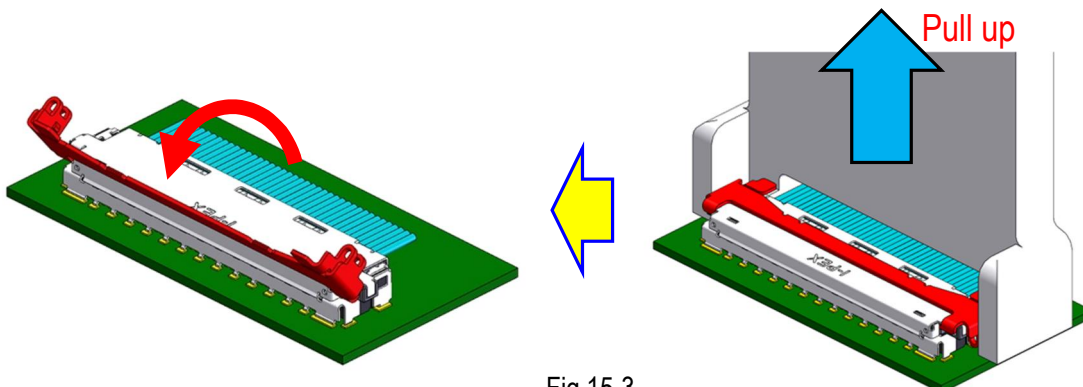

Fig.15-3

- ③ Slide the “pull jig” from the side of a cable and attach to the cable connector.(see Fig.16)
- ④ The jig shall be moved until it reach a stopper just as it hold the cable connector .(see Fig.17)
- ⑤ Lift up the jig vertically to the PCB surface.(see Fig.18)

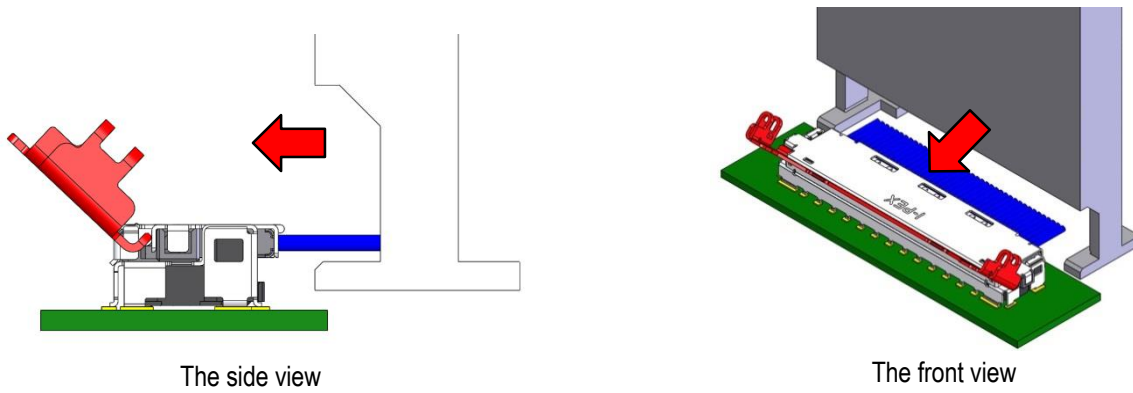

Fig.16

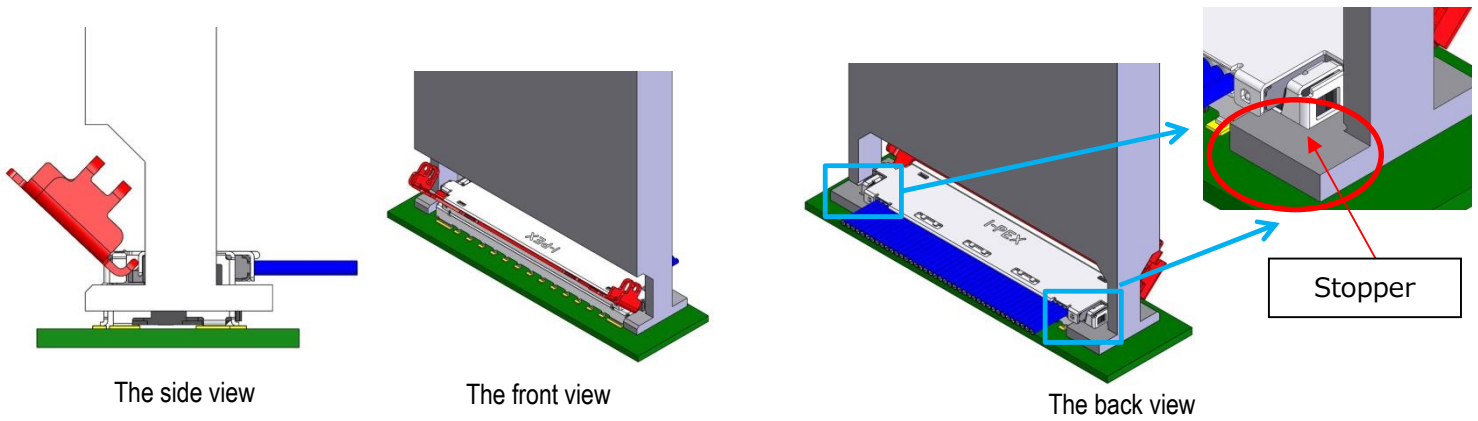

Fig.17

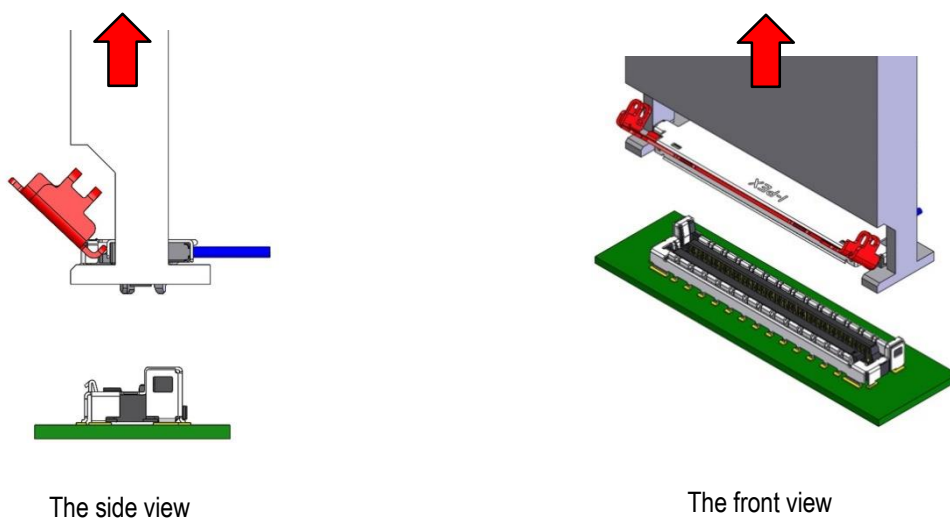

Fig.18

[Unlock Jig]

When withdrawal using Unlock jig, jig shape is presented in Fig.19 for reference.

pos.	A	B	C
30P	17.3	12.5	20.3
40P	21.3	16.5	24.3
50P	25.3	20.5	28.3
60P	29.3	24.5	32.3
70P	33.3	28.5	36.3

Unit: mm

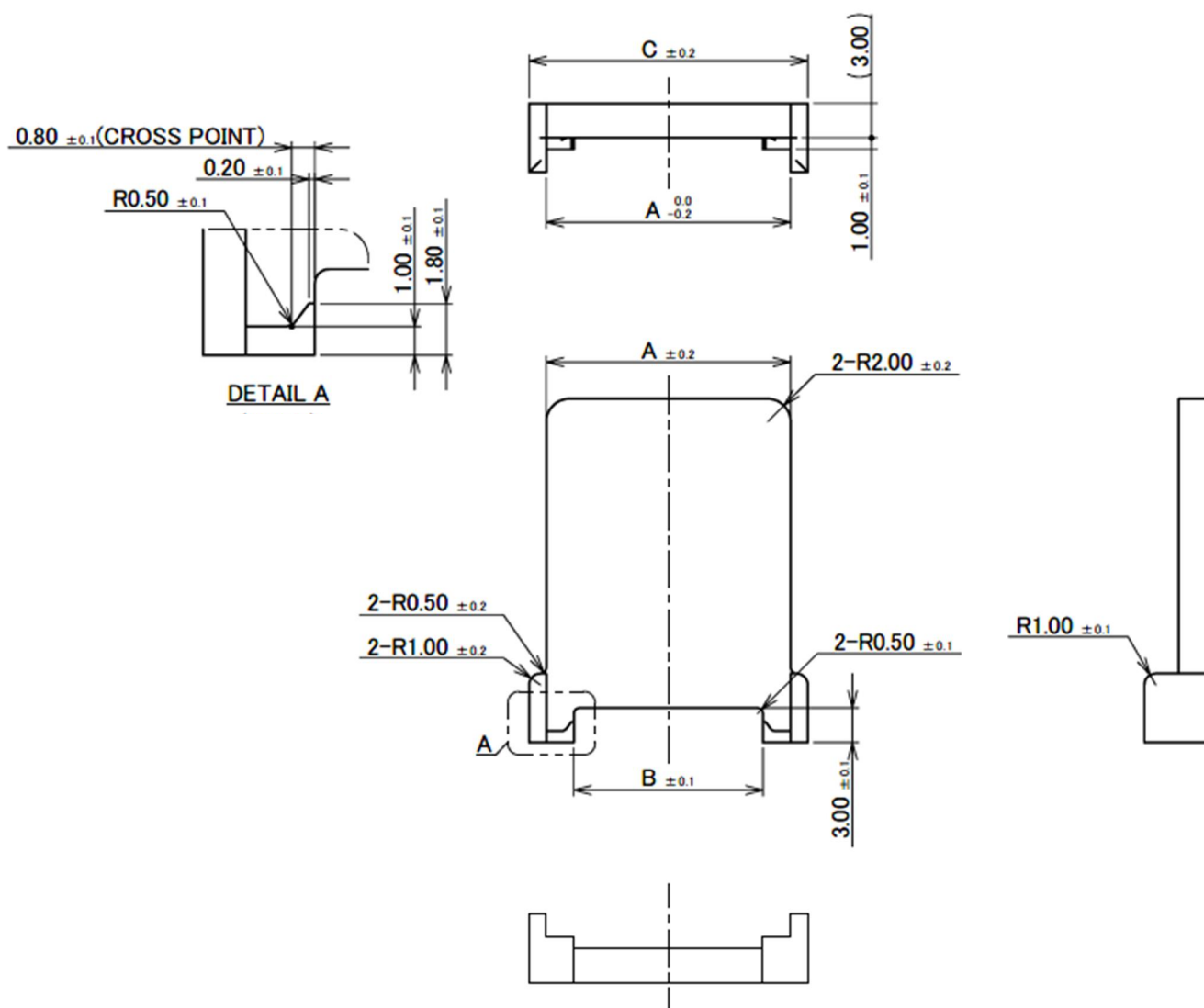

Fig.19 Reference: Unlock Jig

[Pull Jig]

When withdrawal using pull jig, jig shape is presented in Fig.20 for reference.

pos.	A	B	C	D
30P	18.2	16.6	12.8	15.5
40P	22.2	20.6	16.8	19.5
50P	26.2	24.6	20.8	23.5
60P	30.2	28.6	24.8	27.5
70P	34.2	32.6	28.8	31.5

Unit: mm

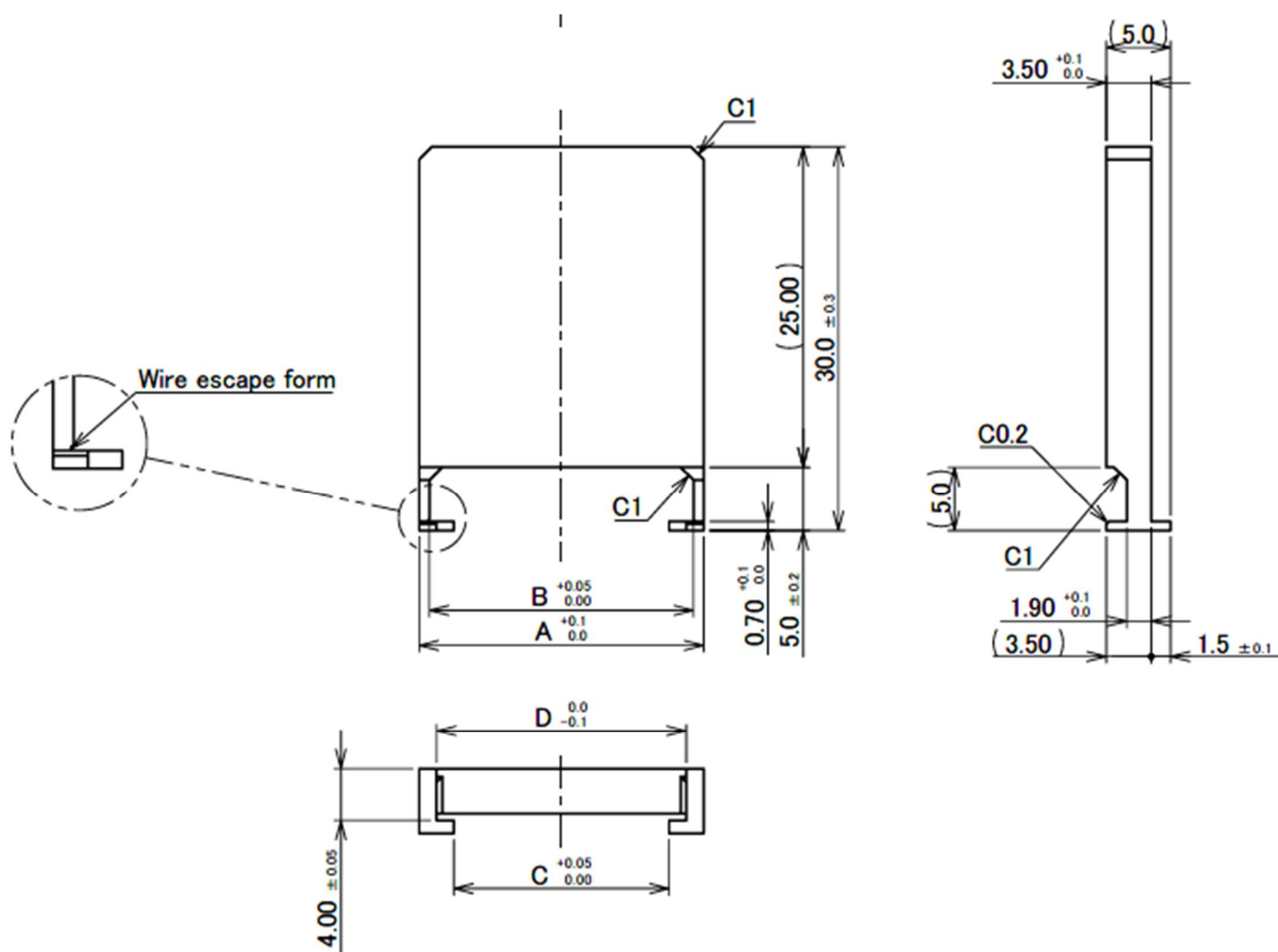

Fig.20 Reference: Plug Pull Jig

CAUTION

- Do not lift lock cover finger hook inward or excessive force applied to the connectors may damage them.
- Do not unmate a cable connector by pulling cable.
- When withdrawing the connector, we recommend that you pull the finger perpendicular to PCB. When removing one side (cable pitch direction) first, please do not apply load to the top of the connector. (see Fig.22)
- Allowable mating angle is shown in Fig.23. When the jig is lifted up to un-mate the cable connector, The unmating angle must be within this tolerance.

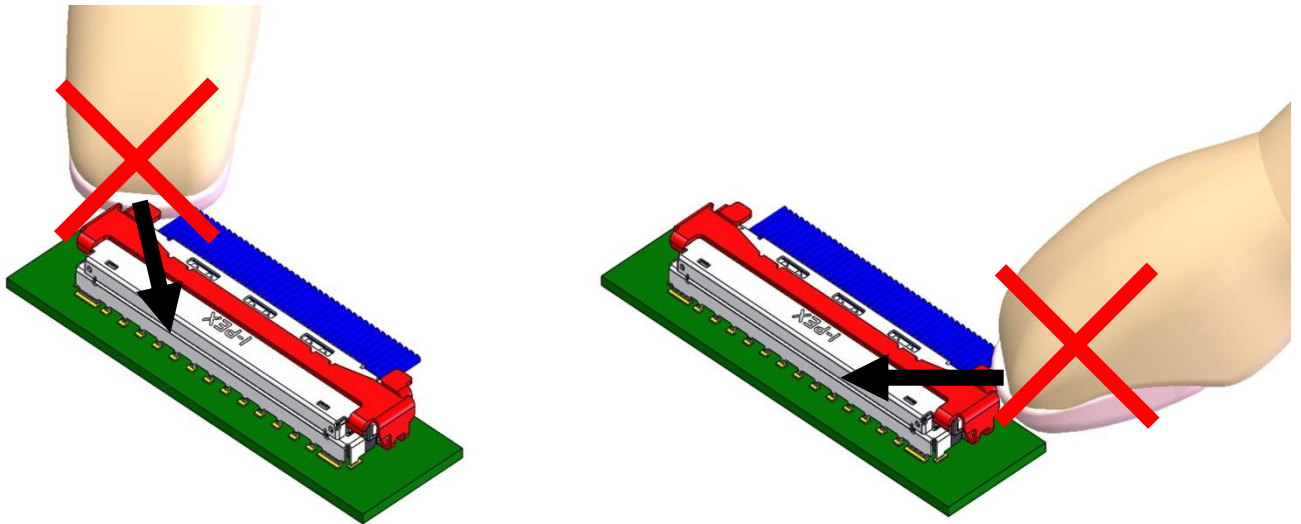

Fig.21

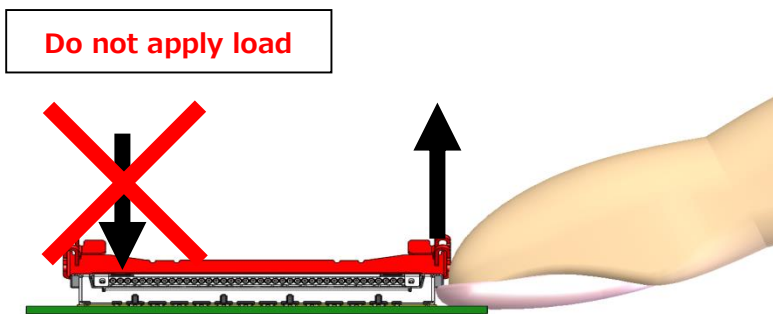

Fig.22

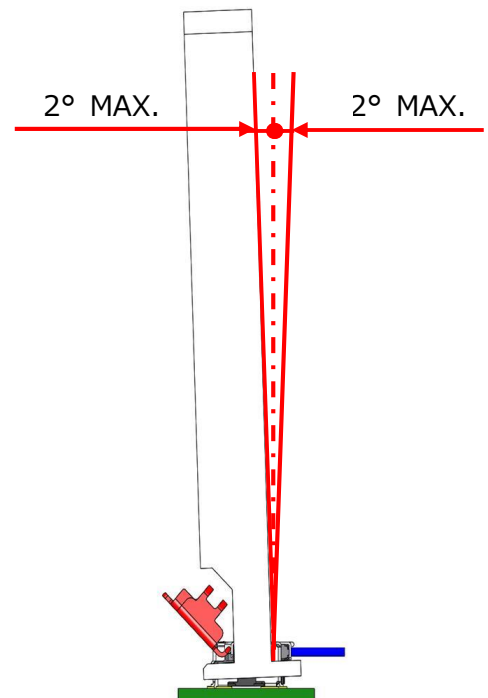

Fig.23 Allowance connector mating angle

CAUTION

·Do not unmate plug before opening lock cover, or it may damage receptacle and decreases plug retention force.

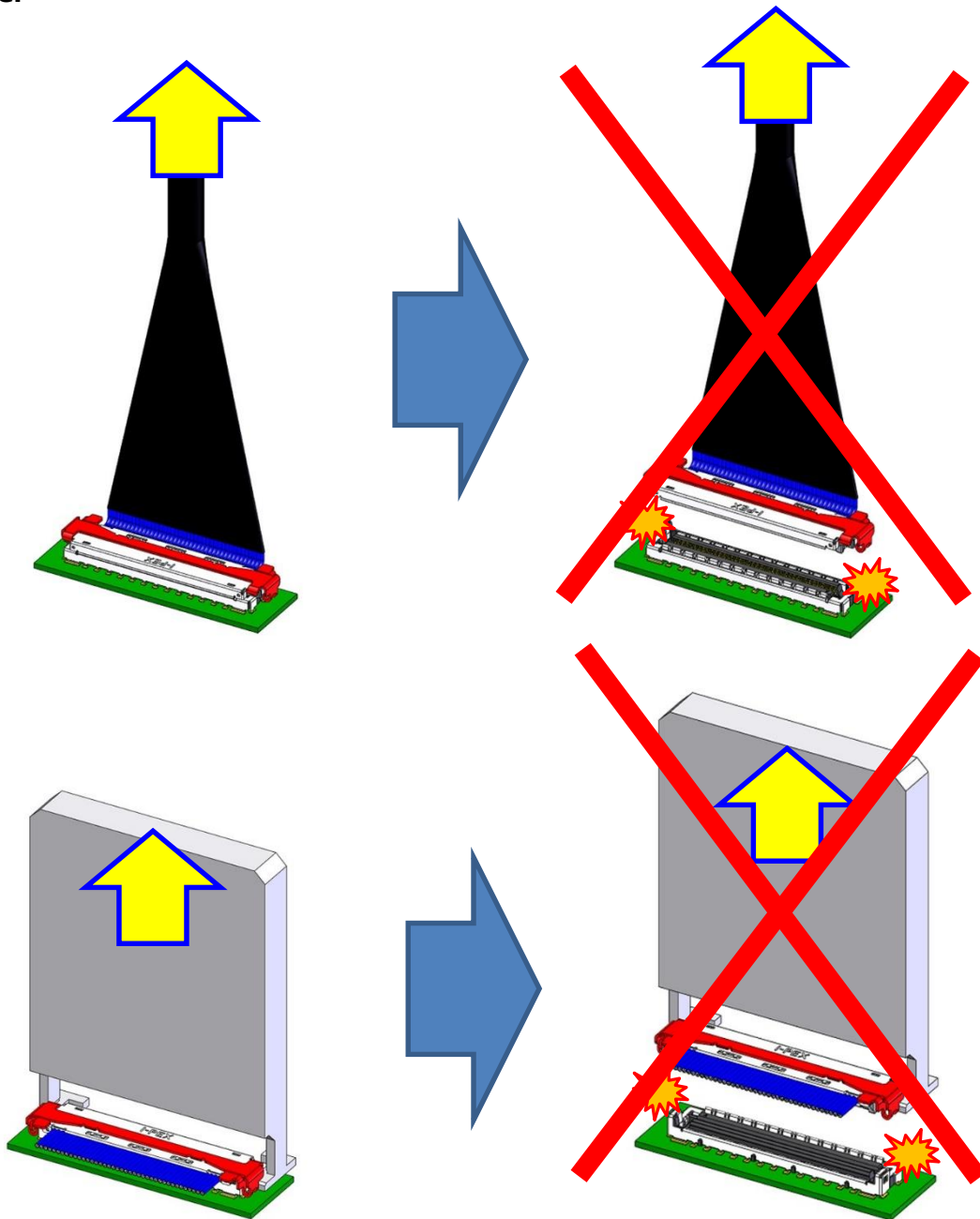

Fig.24 Unmating connectors by force

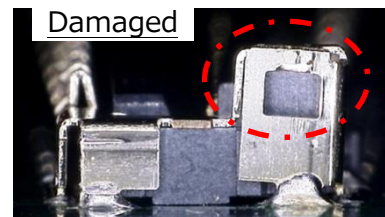
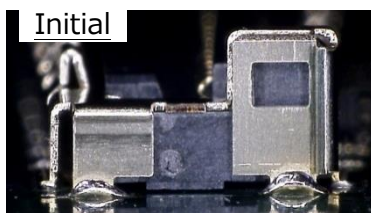

Photo.1 Damaged RECE.

[How to unmate by using PULL TAPE]

※For connector with PULL TAPE HOLDER only

- ① Place the TAPE attached to the PULL TAPE HOLDER vertically against PCB.

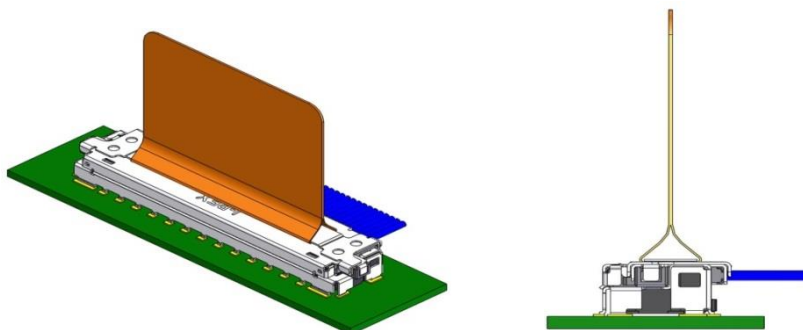

Fig.25 Mated Connector with PULL TAPE

- ② Hold center of the PULL TAPE with fingers and pull up vertically to unmate plug from receptacle.

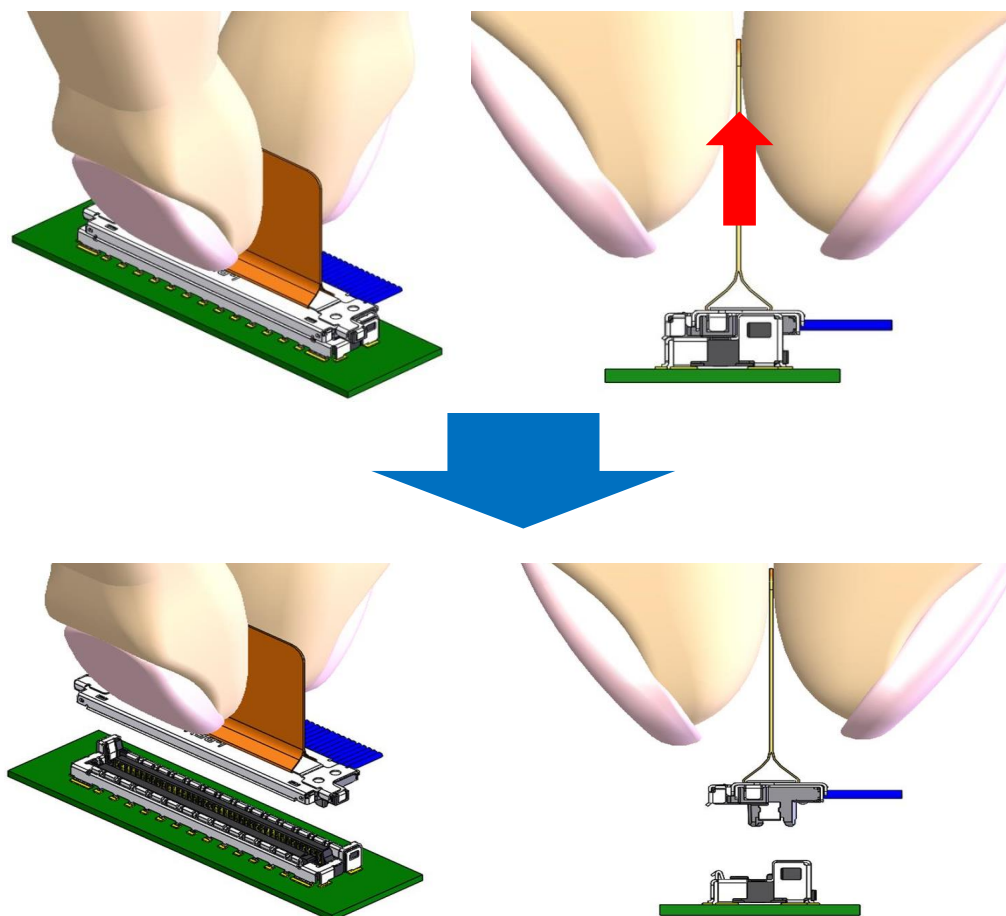

Fig.26 Unmatting connectors by pulling PULL TAPE

CAUTION

- Do not pull one side of the PULL TAPE and rotate it while unmating. [Fig. 27]
- Do not pull the PULL TAPE toward arrowed direction, or it may tear the PULL TAPE and deform SHELL-A and PULL TAPE HOLDER. Make sure to hold center of the PULL TAPE and pull it up vertically. [Fig. 28]
- Do not exceed PULL TAPE slanted allowance angle while connectors were mated. [Fig. 29]

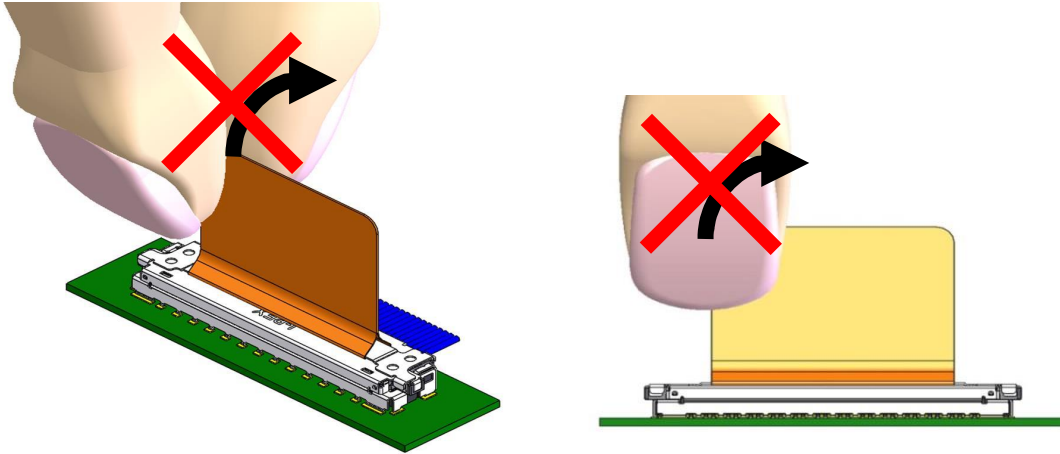

Fig.27 Do not pull one side of the PULL TAPE

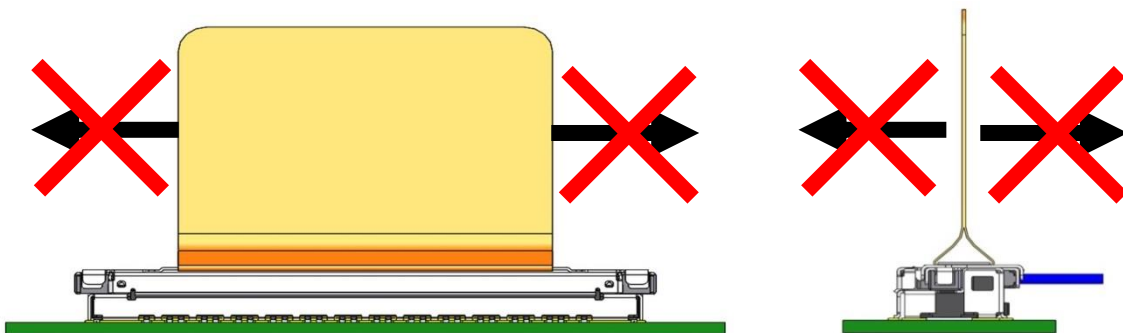

Fig.28 Prohibited PULL TAPE pulling direction

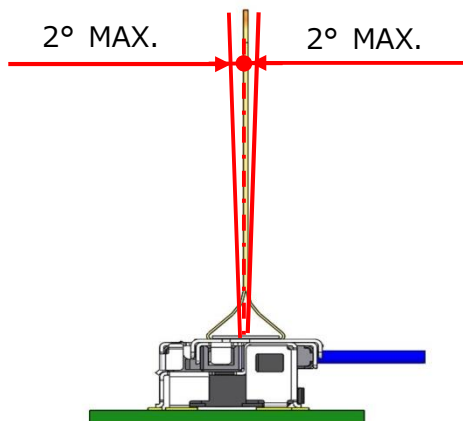
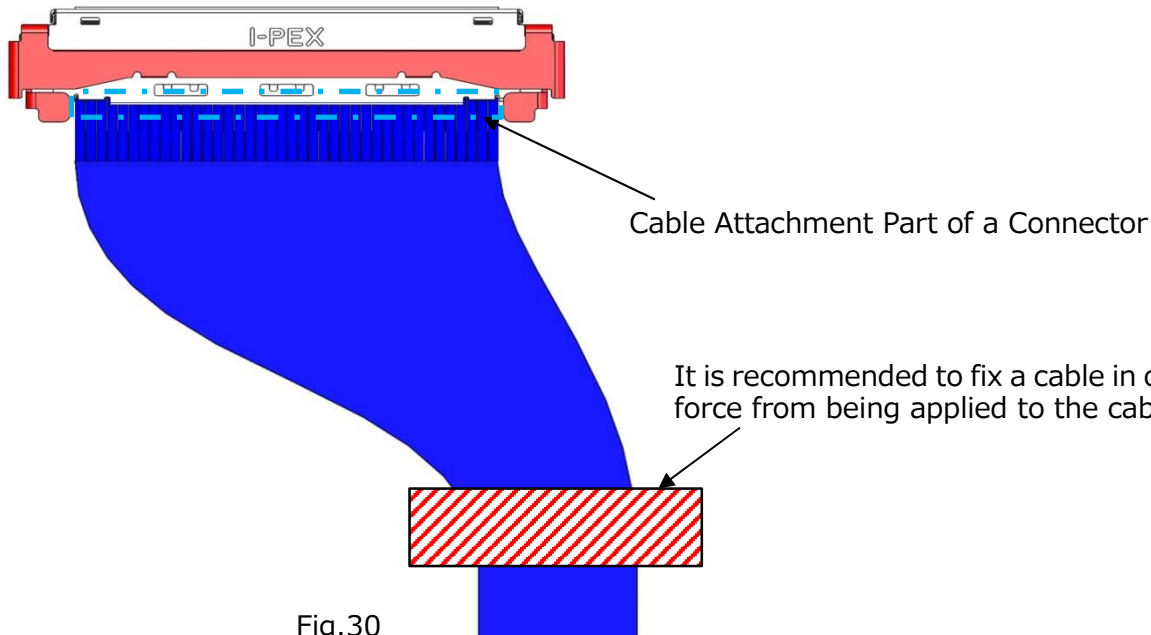

Fig.29 PULL TAPE slanted allowance angle

[Caution in Cable Connector Handling]

- Handle the cable connector carefully in cable harnessing work so that pulling force is NOT applied to specific cables.
- Be careful so that pulling force and/or repeated bending force is NOT applied to the cable attachment part of a cable connector.



- Do not pull cable that will apply excess force to it or it may damage or unmate the connectors. [Fig. 31]
- Do not pull cable to unmate connectors or it may damage receptacle. [Fig. 32]

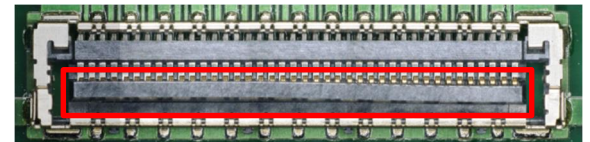
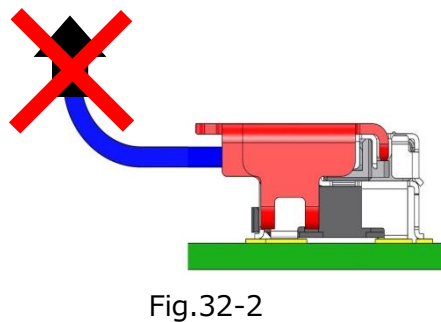
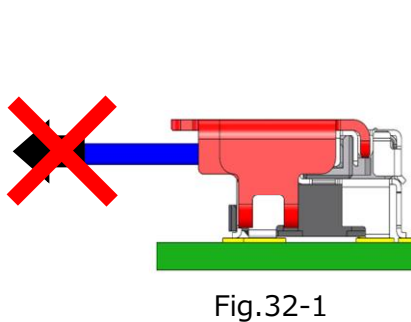
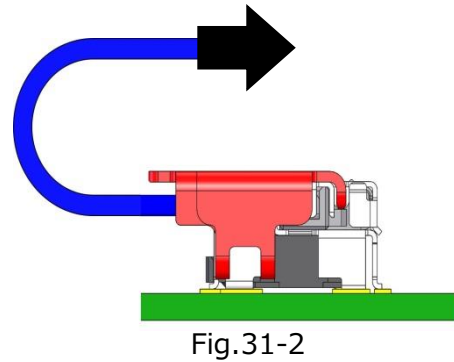
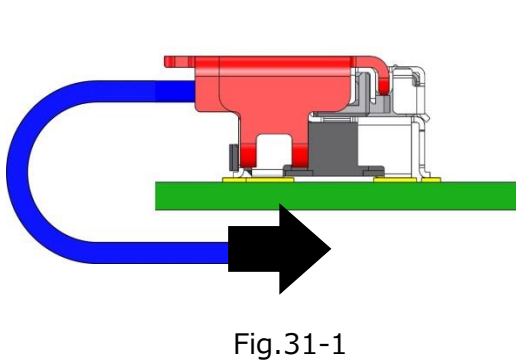

[Recommend Vacuum Nozzle Design for Receptacle]

Figure 33 shows the recommended vacuum areas of receptacle top surface. If current vacuum nozzle for mounter cannot vacuum well, refer to figure 34 for recommended vacuum nozzle design.

•20879-#**E-01 / 21076-0**E-01

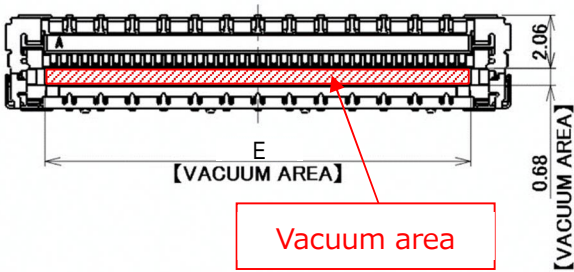

•20879-#**E-02

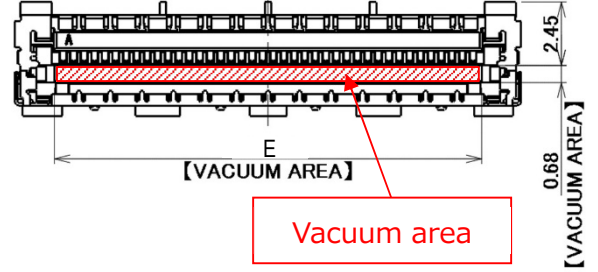

Pos.	E
30	12.07
40	16.07
50	20.07
60	24.07
70	28.07

Fig.33 Recommended Receptacle Vacuum Area [Unit: mm]

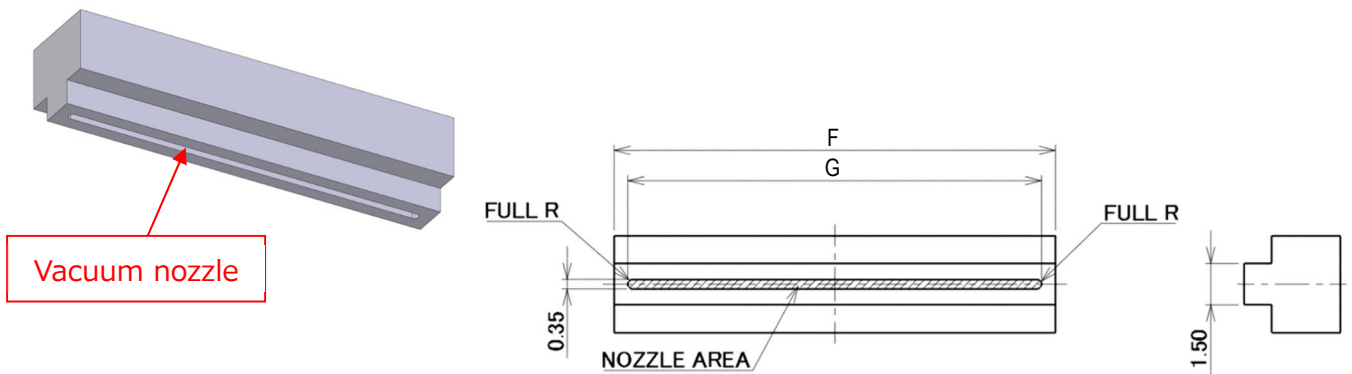

Pos.	F	G
30	12.00	11.00
40	16.00	15.00
50	20.00	19.00
60	24.00	23.00
70	28.00	27.00

Fig.34 Recommended Vacuum Nozzle Design [Unit: mm]