

CABLINE®-CBL

Part No. Plug: 20472-***T-10, Receptacle: 20474-0**E-1*

Instruction Manual

7	S24224	June 4, 2024	K.Tanabe	M.Nakamura	T. Masunaga
6	S22295	June 30, 2022	R. Morita	T. Masunaga	H. Ikari
5	S20392	August 6, 2020	Y. Sasa	T. Masunaga	H. Ikari
4	S17807	November 7, 2017	M. Imai	S. Kawamura	M. Takemoto
Rev.	ECN	Date	Prepared by	Checked by	Approved by

This manual provides the insertion and withdrawal methods and cautions to handle CABLINE-CBL connector properly.

【Connector name and part number】

◆The cable side connector

Product Name : CABLINE-CBL PLUG CABLE ASSEMBLY

Part No. : 20472-#* * T-10

└─ 0: Without Latch Bar
1: With Latch Bar

◆The PCB side connector

Product Name : CABLINE-CBL RECEPTACLE ASSEMBLY

Part No. : 20474-0* * E-1 #

└─ 1: With Boss
2: Without Boss

‘**’ part shows the number of the connector position.

‘※’ part shows the variation. Please refer to a drawing for the details.

【Names of each part of the connector】

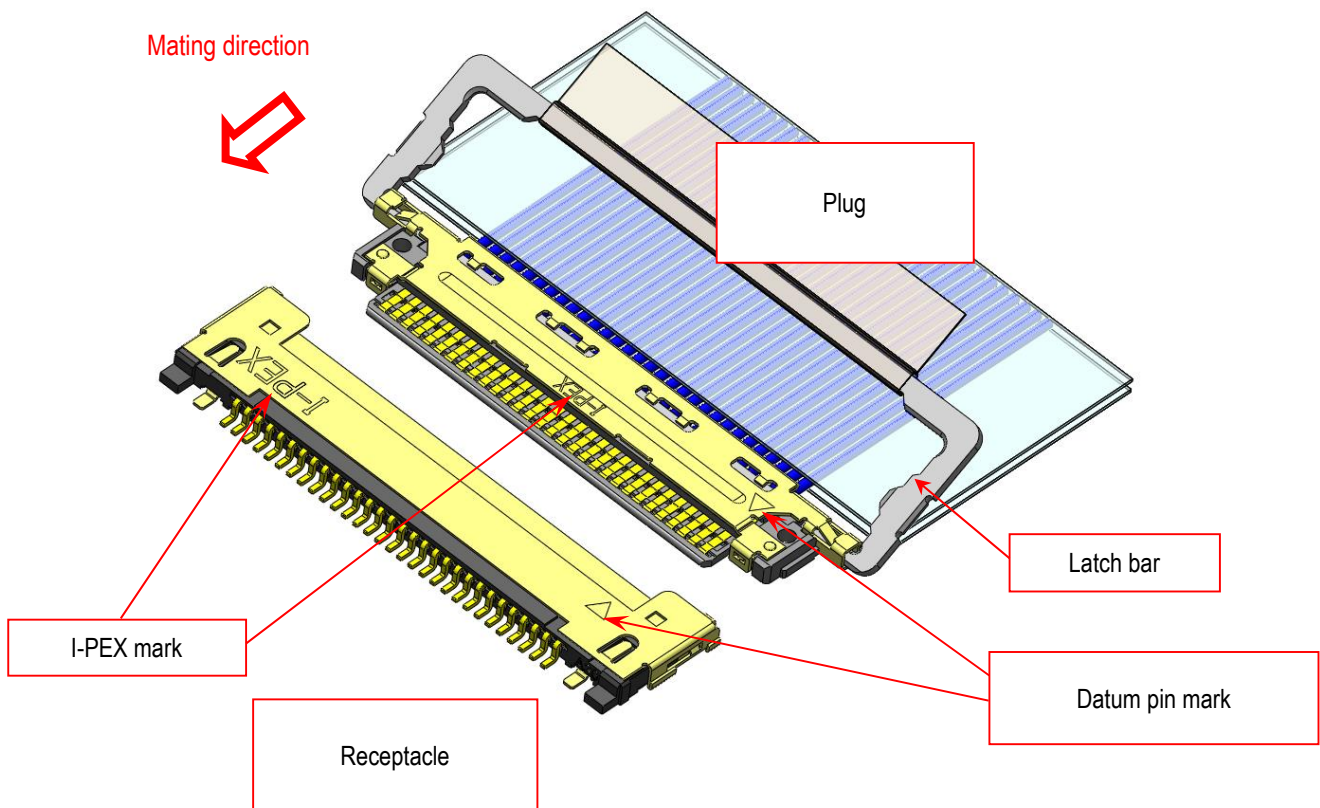

【Connector Insertion Method】

1. Direction to mate

As shown in Fig. 1, cable connector shall be inserted into PCB connector so that the cable locates on the opposite side of datum pin of the PCB connector.

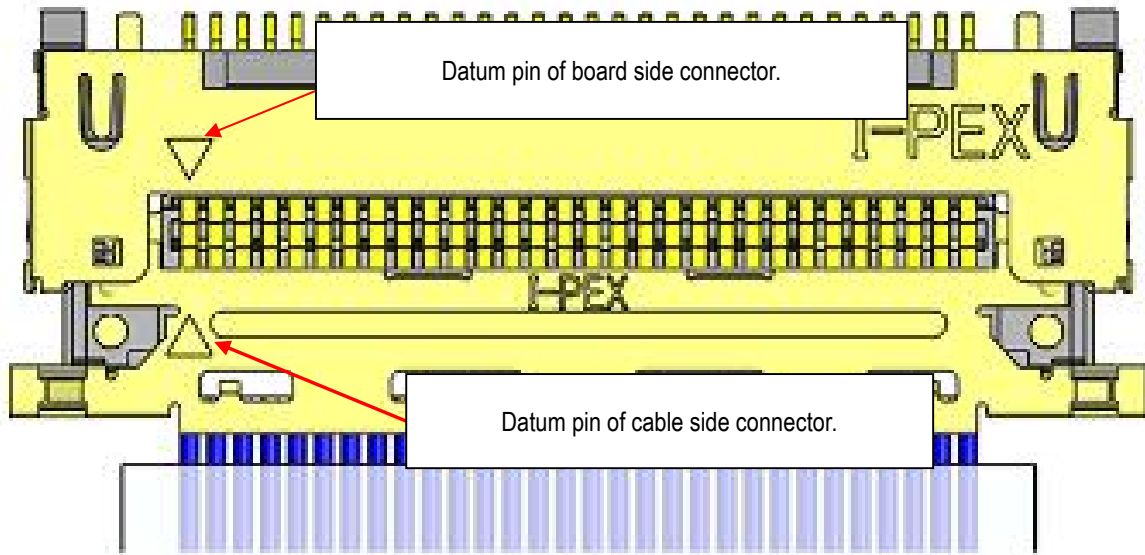

Fig. 1

For the connector with latch bar.

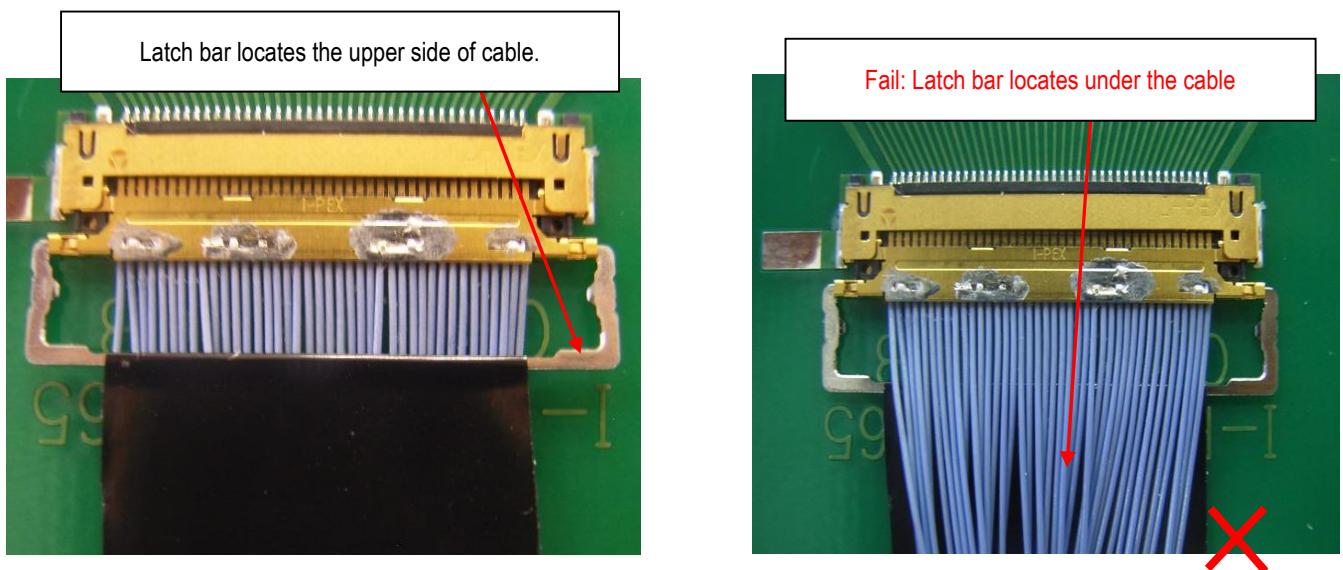

Fig. 2

2. How to mate

- ① Pre-insert the plug connector into the receptacle connector.

The insertion angle in the height direction is within 10° as shown in Fig.3.

Pre-insert until the plug connector is parallel to the receptacle connector as shown in Fig.4

※Pre-insert without applying excessive load in the insertion direction until both sides of the plug connector overlap the receptacle connector.

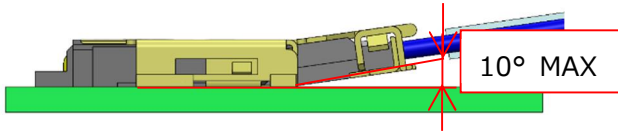
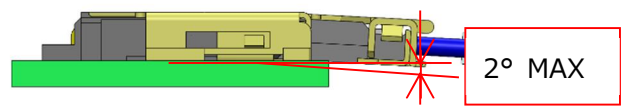
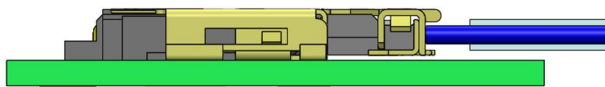

Fig. 3



Pre insert



Check both sides of the plug connector overlap the receptacle connector.

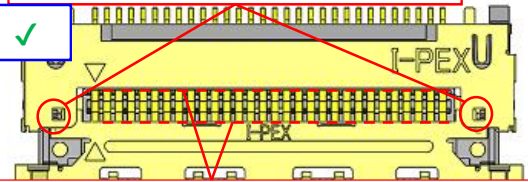

Check the plug connector and receptacle connector are

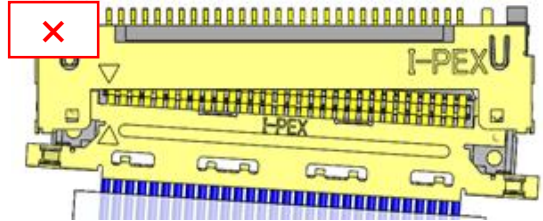

Fig. 4

<Caution 1> If Pre-insert is NG, repeat step ①.

- ② Push both ends of cable connector horizontally as shown in Fig.5 until it is locked.

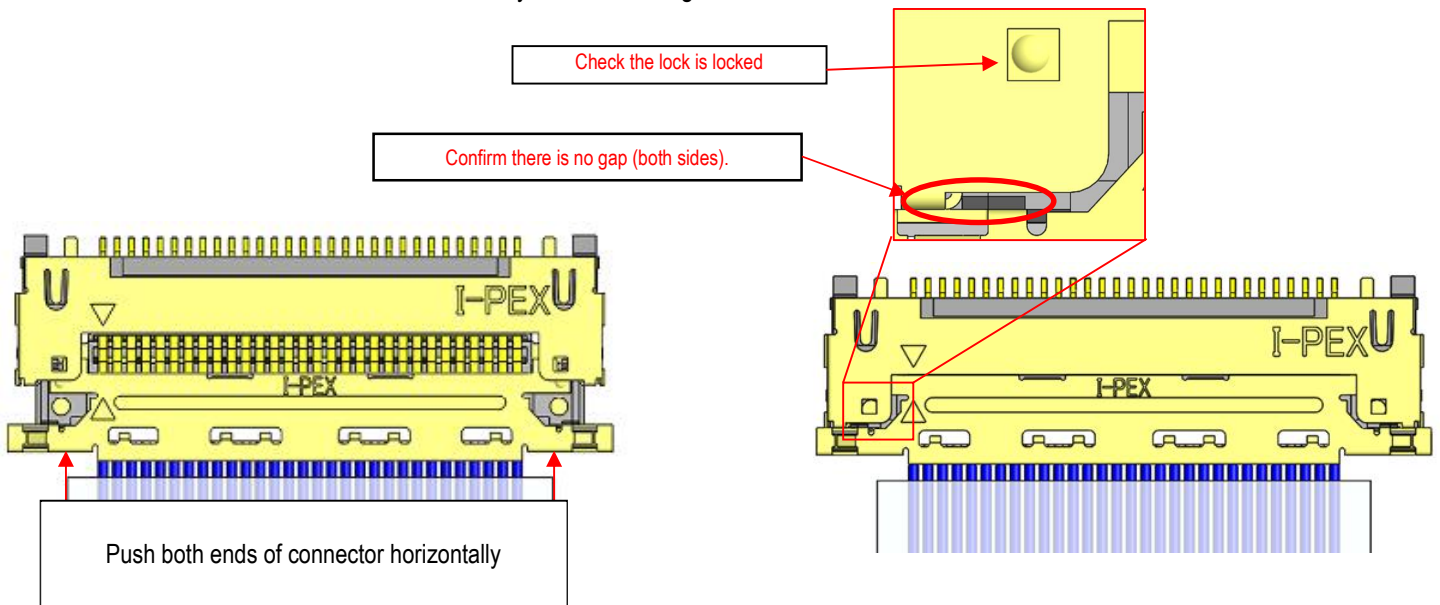

Fig. 5

<Caution 2> If you push one side, the mating may be incomplete as shown in Fig. 6.

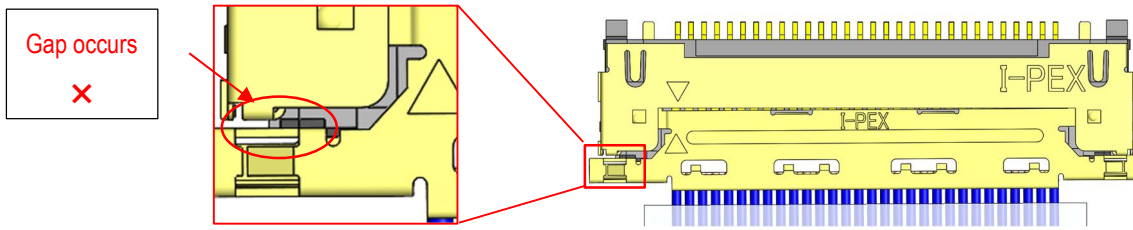

Fig. 6

<Caution 3> Don't insert the plug connector into the receptacle connector the state shown in Fig.7.
The connector may be damaged and no conductivity.

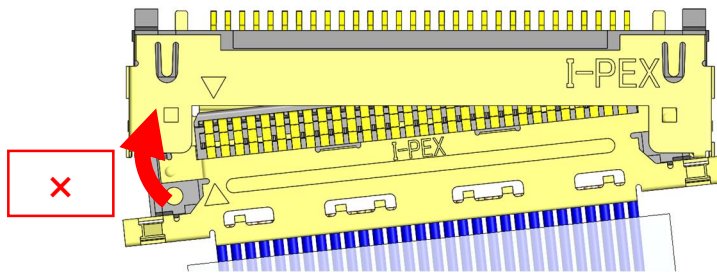

Fig. 7

<Caution 4> Don't insert the plug connector into the receptacle connector before it has not been pre-insert as shown in Fig.8.
The connector may be damaged.

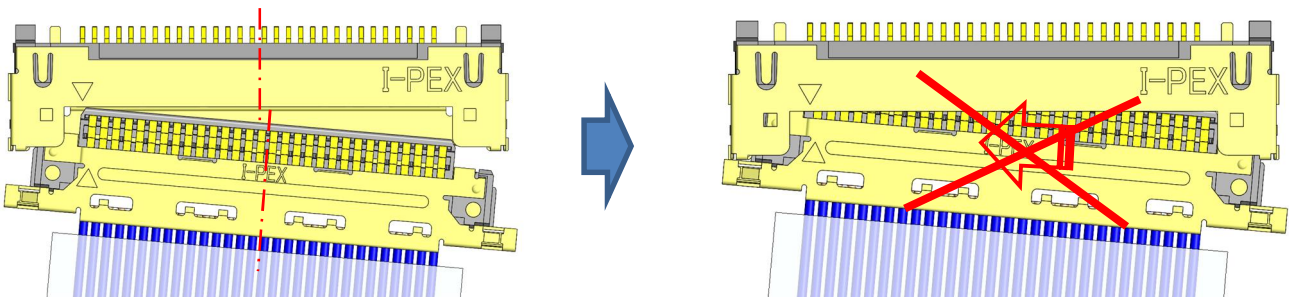

Fig.8

For the connector with Latch bar.

From temporary inserting condition as shown in Fig. 9, turn Latch bar to the PCB connector side and push both ends of cable side connector horizontally. When the lock hole is locked, the mating is completed.

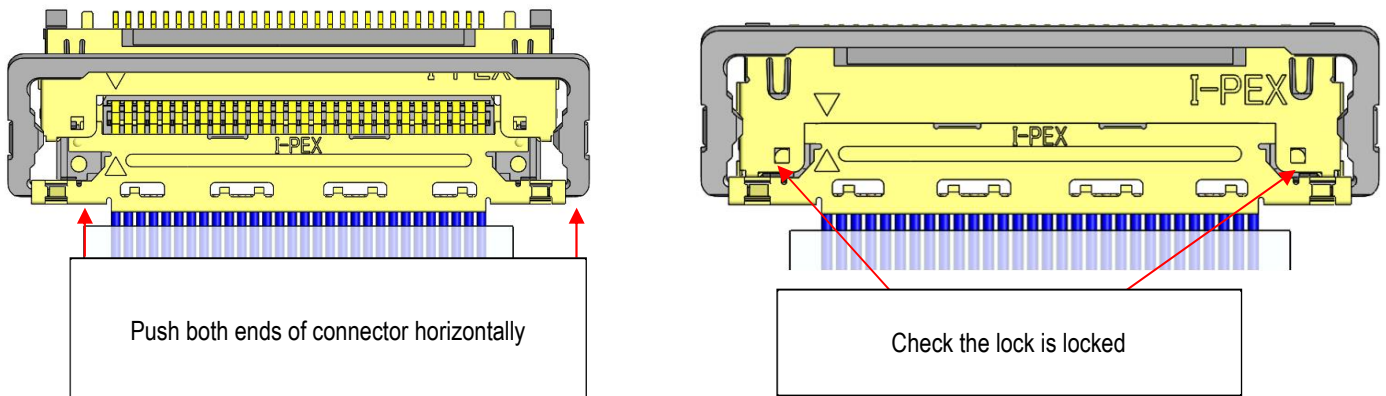

Fig. 9

【Mating jig】

When mating plug connector, if it is difficult to mating correctly, please use reference jig as shown in Fig.10.

< Shape of mating jig (reference) >

	A	B	C	D	E	F	G
30P	18.60	15.00	9.00	16.65	18.30	19.60	13.00
40P	22.60	19.00	13.00	20.65	22.30	23.60	17.00

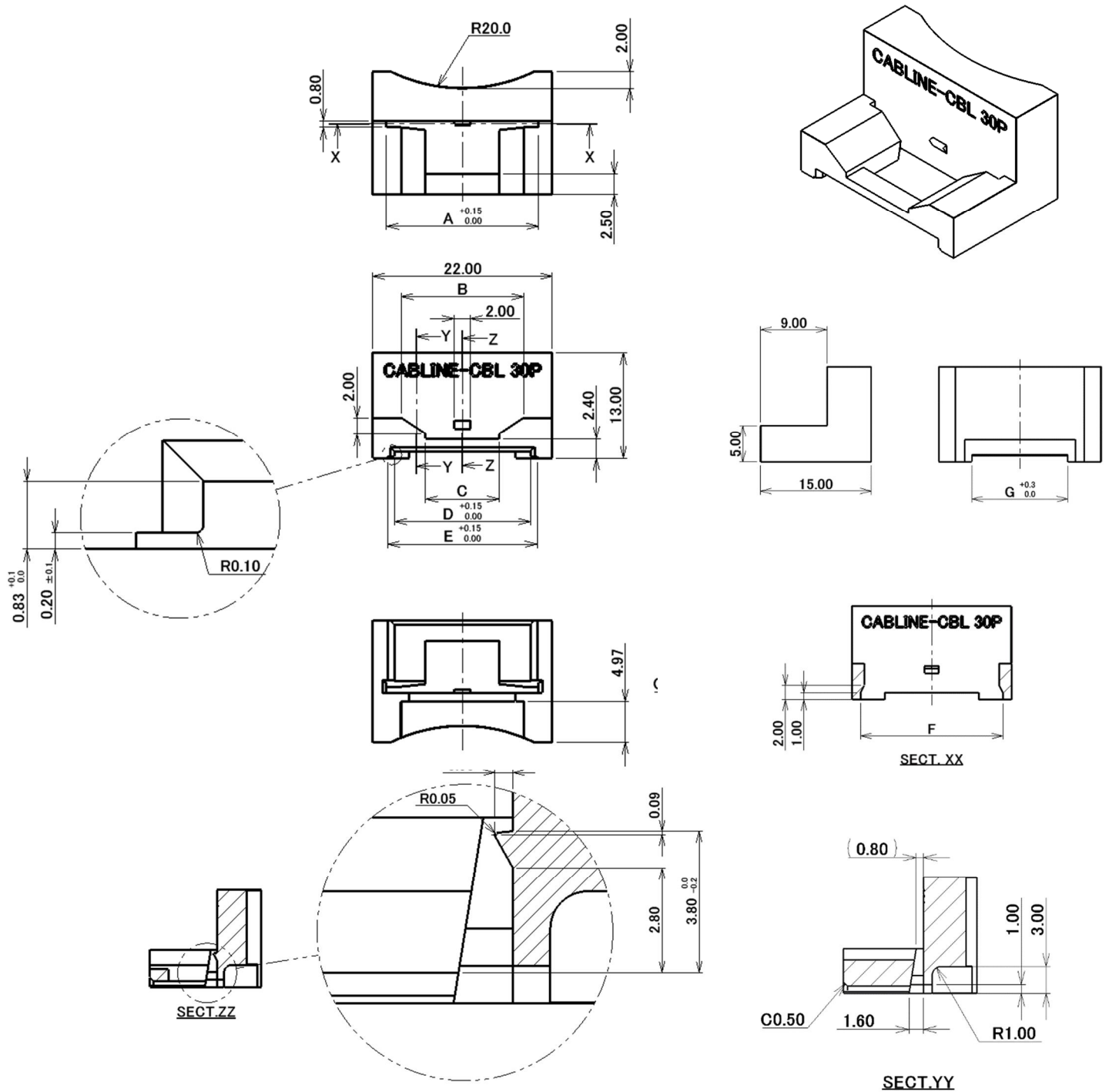

Fig.10

< How to use of mating jig >

- ① Stand up the Lock bar vertically and fit the jig from above. (Fig.11)

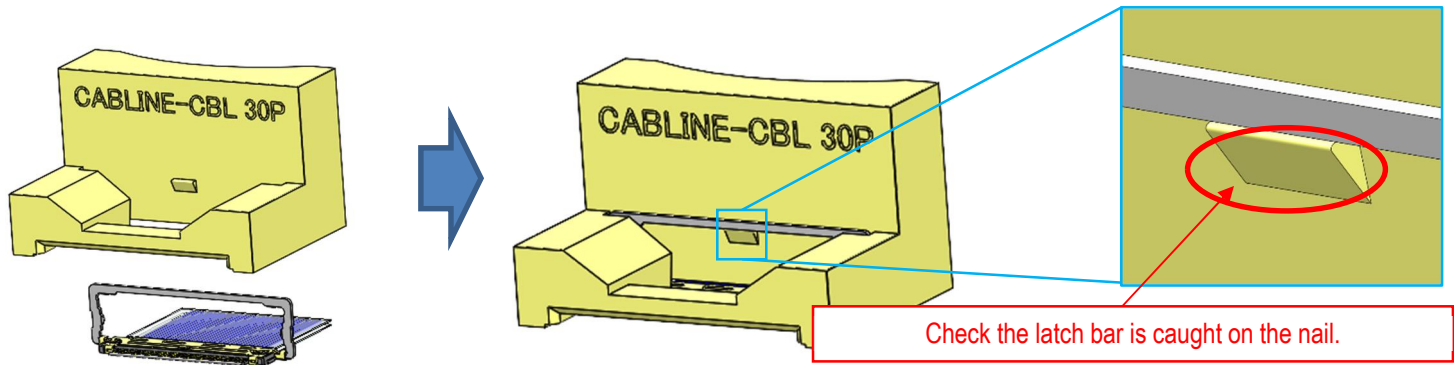

Fig.11

- ② Set the mating jig with the plug connector attached as shown in Fig. 12.

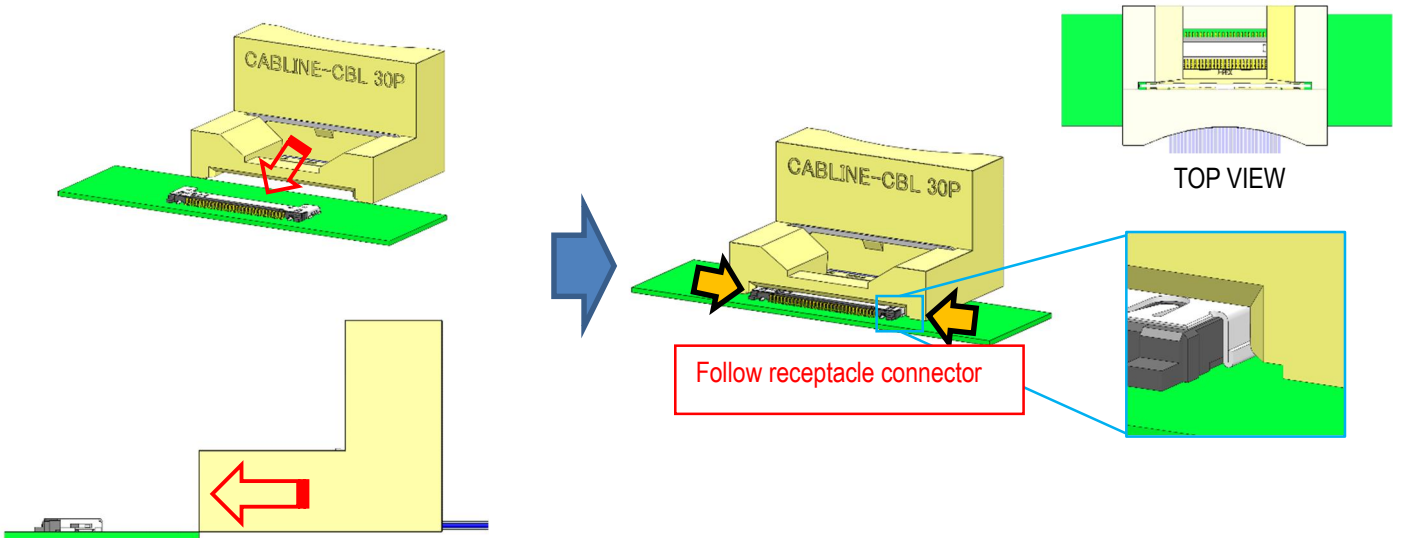

Fig.12

- ③ Pre-insert mating jig horizontally, check the plug connector and receptacle connector are parallel, and then insert the plug connector. (Fig.13)

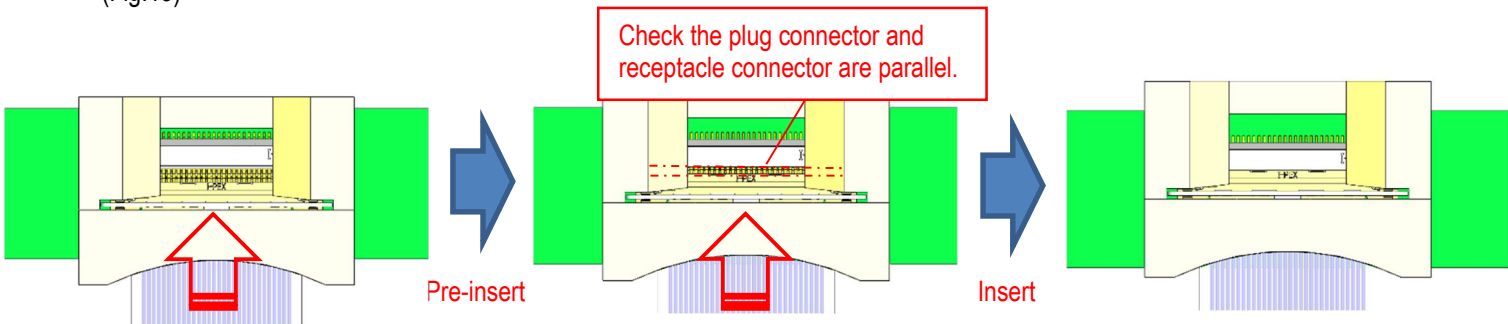

Fig.13

④ Remove the mating jig vertically as shown in Fig.14.

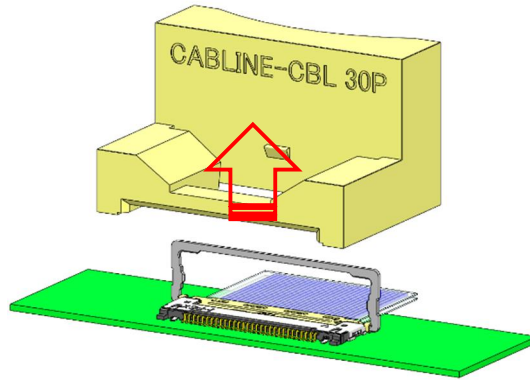

Fig.14

<Caution 5> Please do not apply force toward the PCB side to the plug connector in insertion. PCB will be damaged like below and it may cause the disconnection of the pattern or the short.

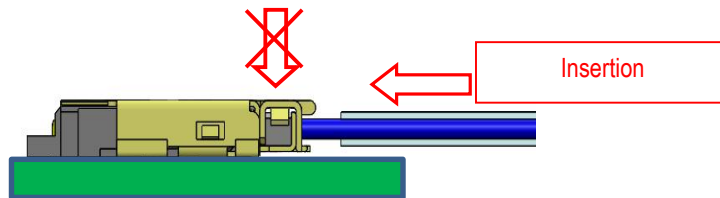

Fig.15

For the connector with Latch bar.

In insertion, in case you mate the connector pushing latch bar as shown in Fig. 16, there are possibilities to cause latch bar deformation or the rotation axis dropping out from the connector. Please don't push latch bar.

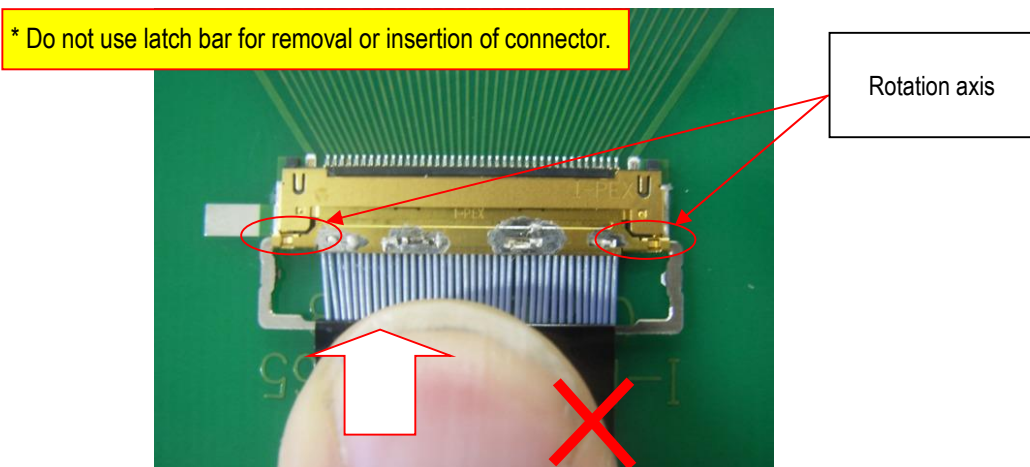
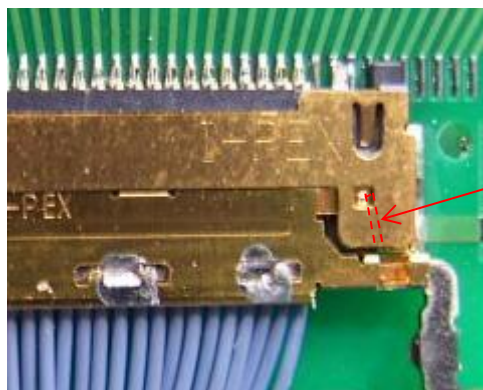

Fig.16

Receptacle shell has an insertion guide as shown in the photograph below.

Please insert connector along this guide.

As long as inserting along the guide, deformation of the connector doesn't occur.



The guide shape on the back side of shell

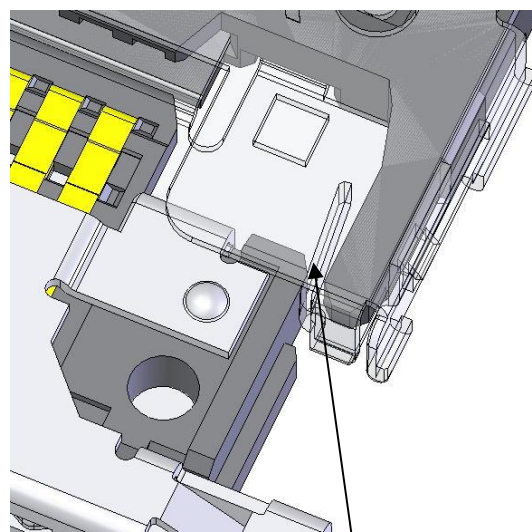
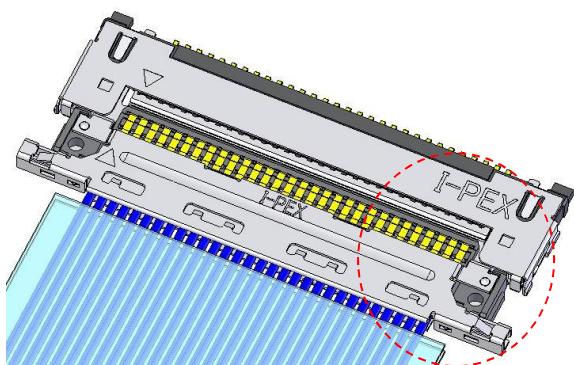

Receptacle shell guide

Fig. 17

3. How to lock

After mated, latch bar rotated and push both ends of latch bar vertically as shown in Fig. 18 until it is locked.

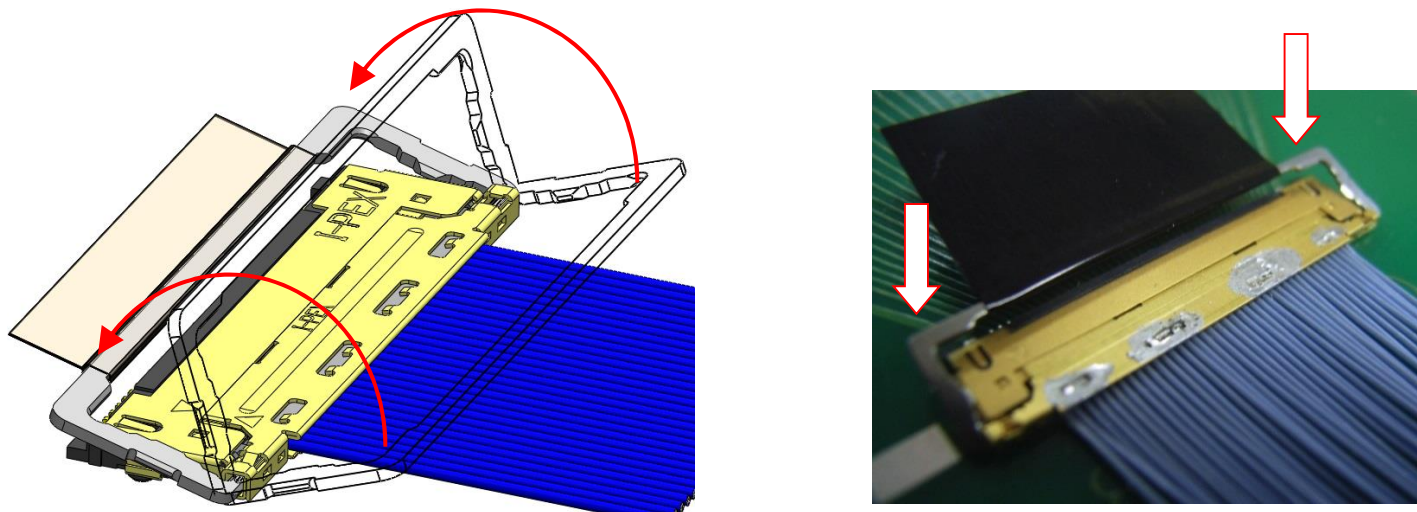

Fig. 18

Contents of confirmation :

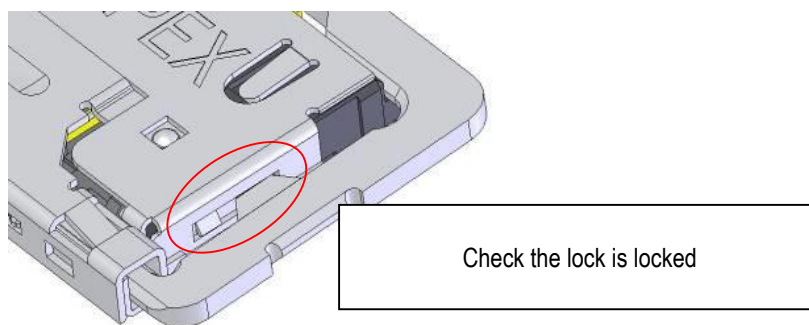
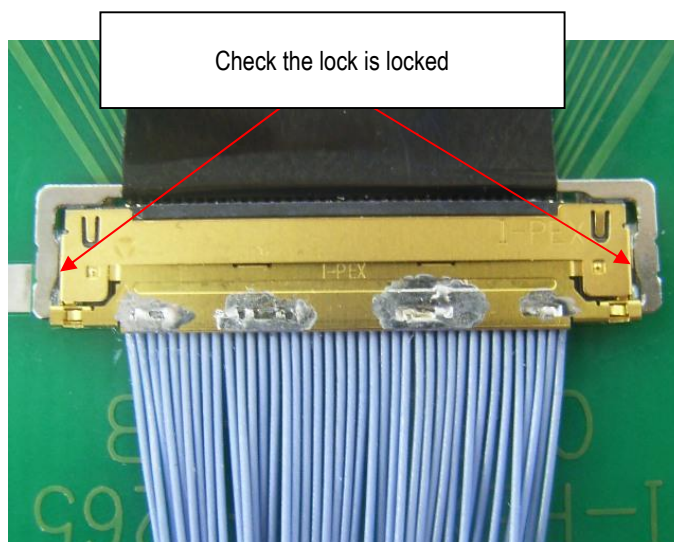

Fig. 19

【Connector Withdrawal Method】

1. Withdraw connector

Withdraw cable side connector in parallel with board side connector as shown in the Fig 20.

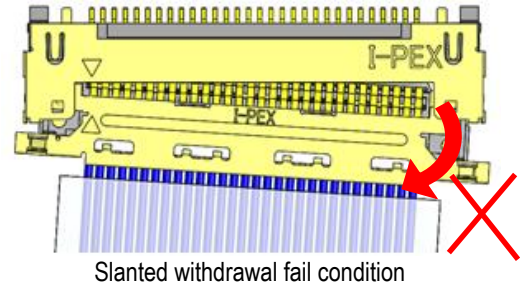
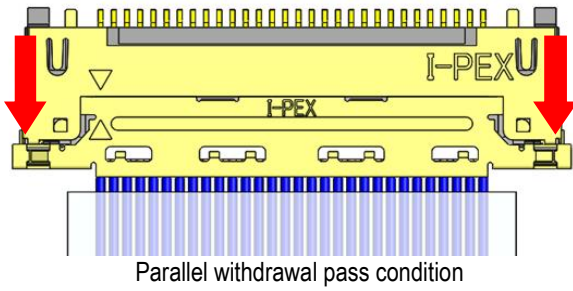
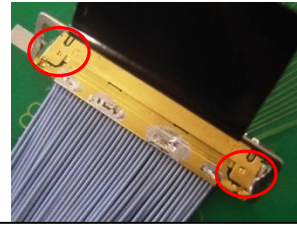
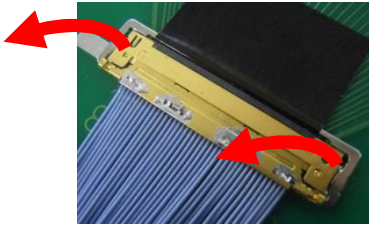

Fig. 20

For the connector with Latch bar.

Pull up both ends of latch bar vertically at the same time as shown in Fig. 21 until the right and left sides of locks are unlocked.



Check the lock is unlocked

Fig. 21

Withdraw cable side connector in parallel with board side connector as shown in the Fig 22.

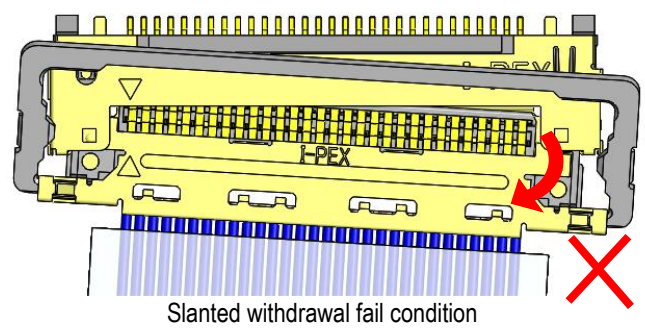
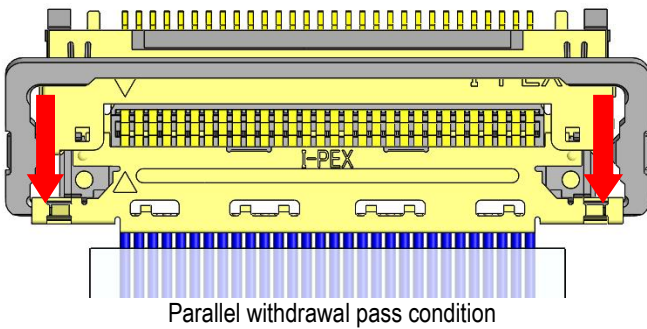

Fig. 22

Deformation of the latch bar occurs, if you pull up only center of latch bar.



Fig. 23

<Caution 6> Please do not apply force toward the PCB side to the plug connector in withdrawal. PCB will be damaged like below and it may cause the disconnection of the pattern or the short.

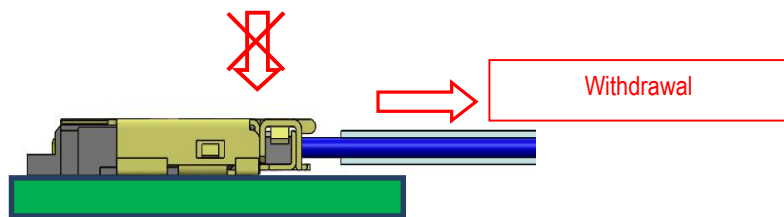

Fig. 24

For the connector with latch bar.

In withdraw, in case you unmate the connector pulling center of latch bar as shown in Fig. 25 there are possibilities to cause latch bar deformation or the rotation axis dropping out from the connector.

Please don't pull latch bar.

* Do not use latch bar for removal or insertion of connector.

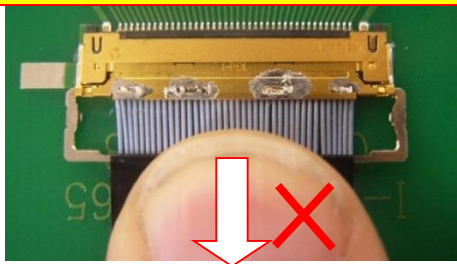
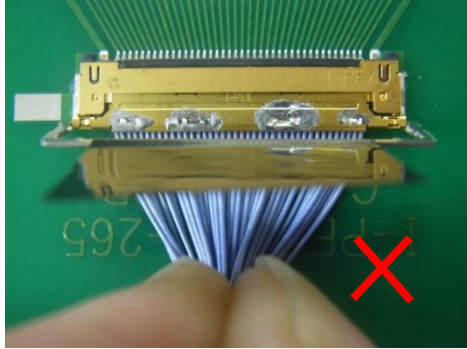

Fig. 25

【Caution in cable connector handling】

- In case you withdraw connector by pulling cable, there is possibility to break the cable. Please avoid such withdrawal. In addition, such withdrawal can cause locally-force to cable and the inner conductor can be damaged. Especially, slanted withdrawal by some cables is more dangerous. Please be careful.



Fail

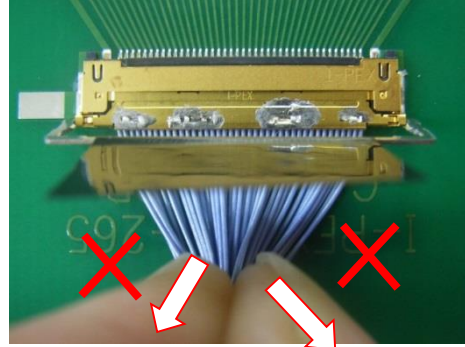

Fail

Fig. 26

In case the cable is pulled to the vertical direction, shell of the PCB side connector can deform. Please don't pull vertically. Similarly, latch bar should not be pulled to the vertical direction.

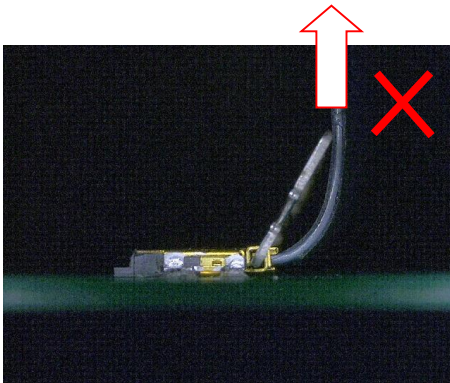

Fail for handling

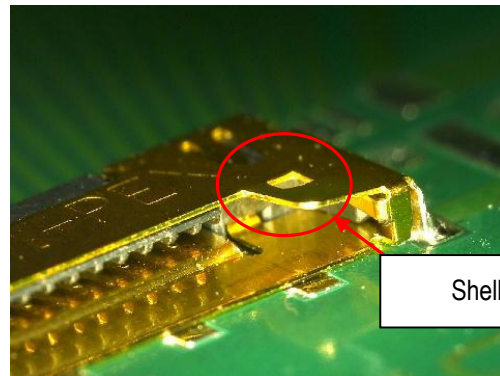

Shell deformation

Fig. 27

- In cable harnessing work, be careful NOT to apply the pulling force to specific cables.
Be careful NOT to apply the pulling force or repeated bending force to the cable attachment part of a cable connector.

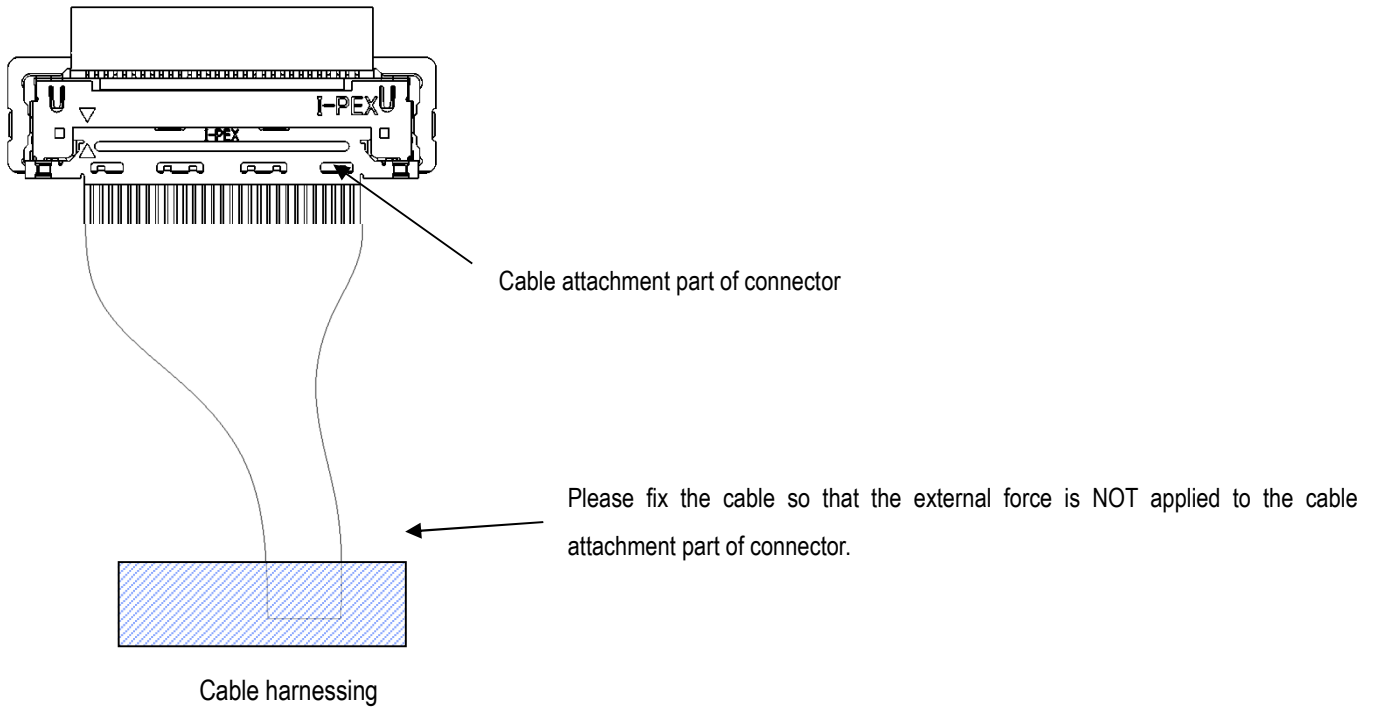

Fig.28

- Continuous force of the direction shown in black arrow in Fig. 29 can damage connectors or cause the coming off from receptacle connector. Please be careful NOT to apply such force.

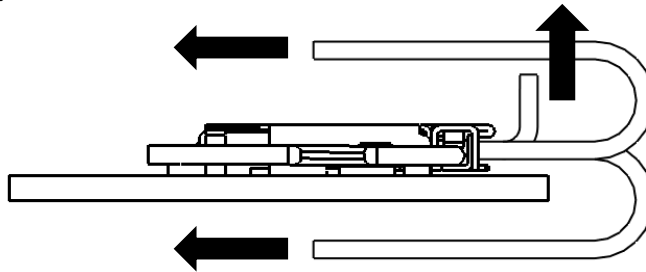

Fig. 29

- Do not wipe metal area of connector with chemical liquid, such as alcohol, or rust due to corrosion may cause electrical discontinuity.

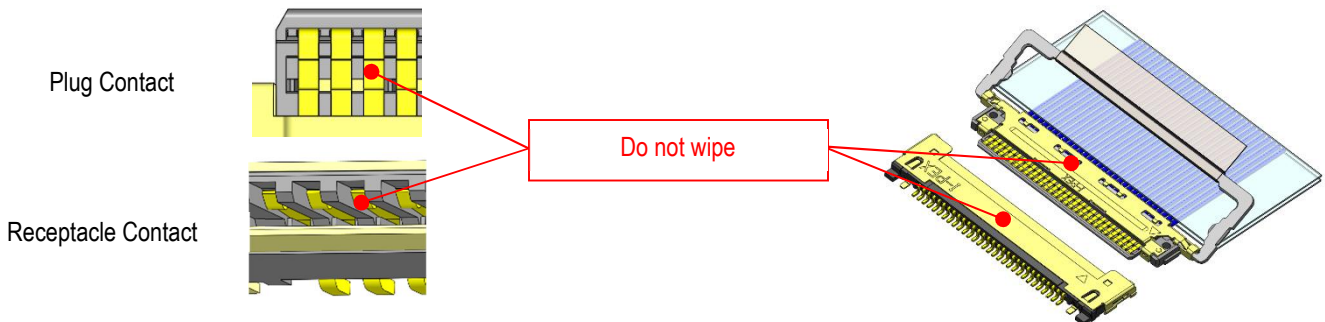

Fig. 30

【Cautions for electrical inspection when using plug】

Please note that damage, buckling and offset will occur on the receptacle when the receptacle is inserted into the damaged or distorted plug housing, and these may cause short circuit.

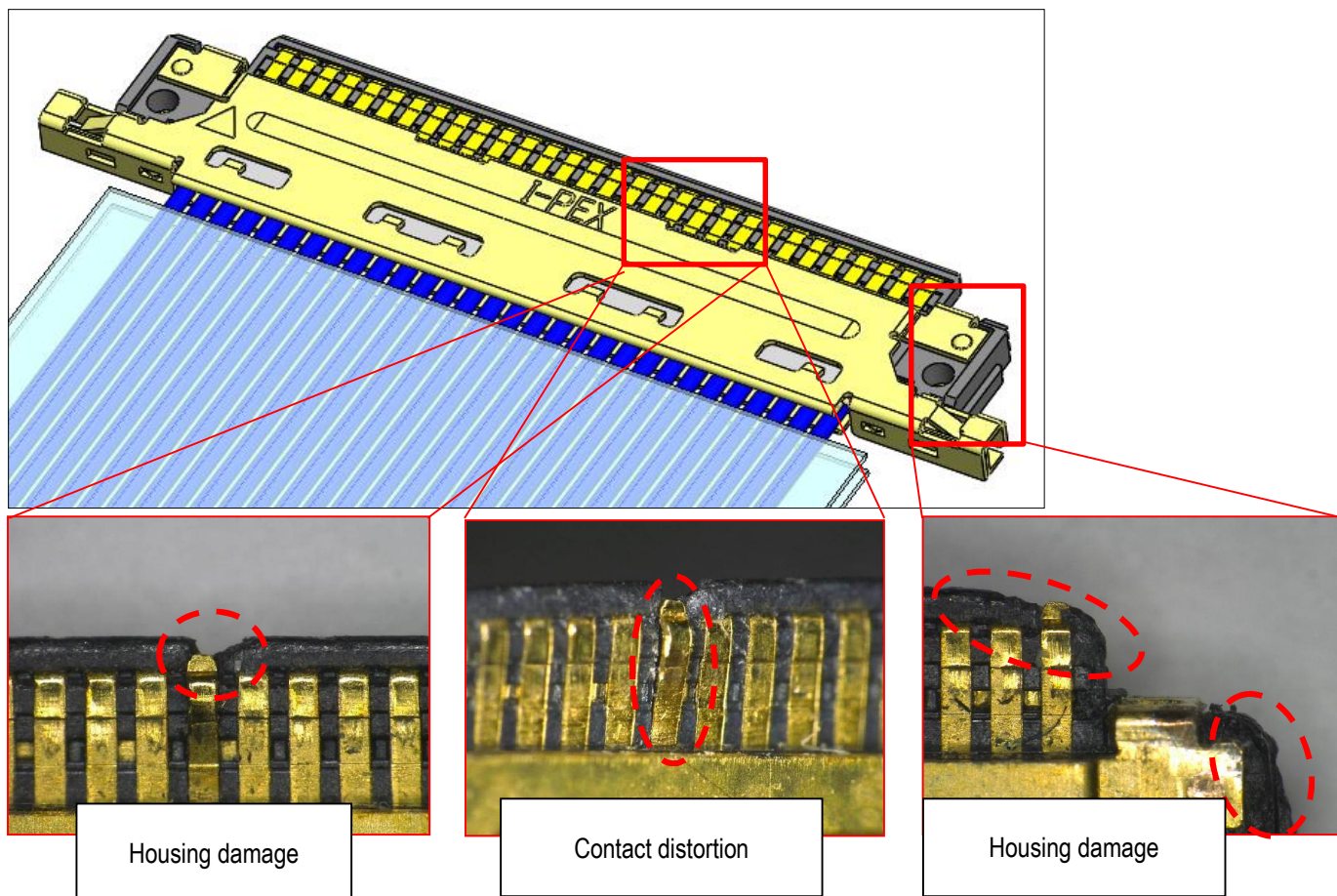

Fig. 31