

# AP-10

Part No. PLUG: 3531-0001-00T  
 3539-0001-45T  
 21037-001E  
 RECEPTACLE: 3532-0001-00T  
 21022-001E

## Instruction Manual

2	S24374	September 17, 2024	F.Jin	S .Kamada	Y.Hashimoto
1	S24117	April 2, 2024	W. Lau	Y. Shimizu	M. Takemoto
0	S22382	August 30, 2022	K. Tanaka	-	Y. Hashimoto
Rev.	ECN	Date	Prepared by	Checked by	Approved by

This manual outlines precautions for proper handling of I-PEX AP-10 power terminal.

**【Part name and part number】**

Product name AP-10 PLUG

Product No.

	Part No.	
Plug Height	h=7.5mm	h=14.5mm
Sn Plating	3531-0001-00T	3539-0001-45T
Sn Plating with cap	-	21037-001E

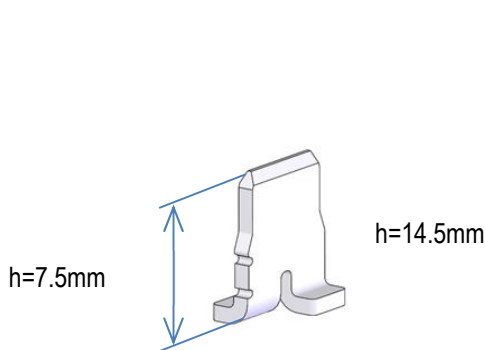

Fig.1:3531-0001-00T

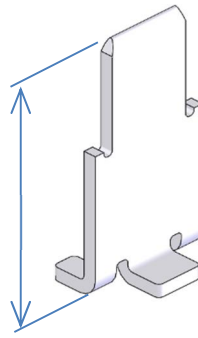

Fig.2:3539-0001-45T

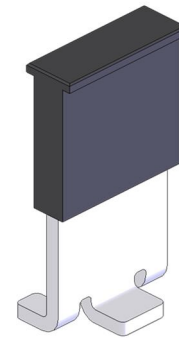

Fig.3 :21037-001E

Product name AP-10 RECEPTACLE

Product No.

	Part No.
Sn Plating	3532-0001-00T
Sn Plating with cap	21022-001E

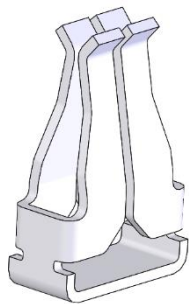

Fig. 4 :3532-0001-00T

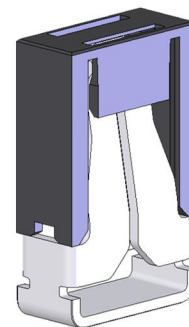

Fig.5 :21022-001E

【Mating condition】

Plug Height	h=7.5mm	h=14.5mm
Plug	3531-0001-00T	3539-0001-45T
Receptacle	3532-0001-00T	3532-0001-00T

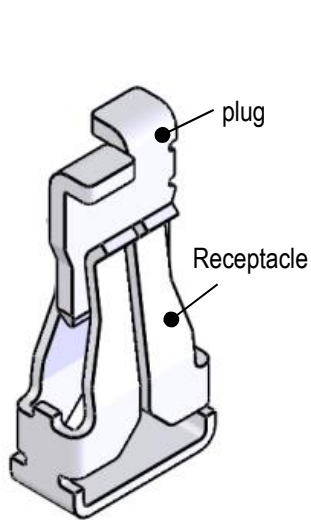

Fig. 6

Plug: 3531-0001-00T

Receptacle: 3532-0001-00T

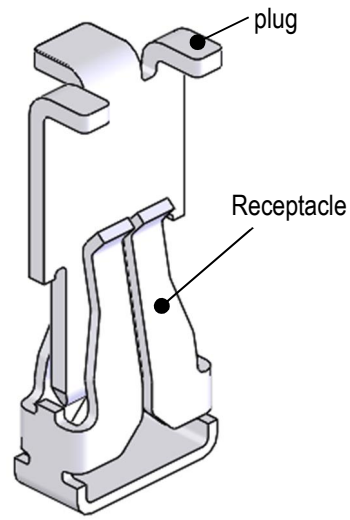

Fig. 7

Plug: 3539-0001-45T

Receptacle: 3532-0001-00T

## 【PLUG CAP handling point】

When remove the CAP, hold side surface of the PLUG CAP and pick up the CAP vertically from the PCB surface.

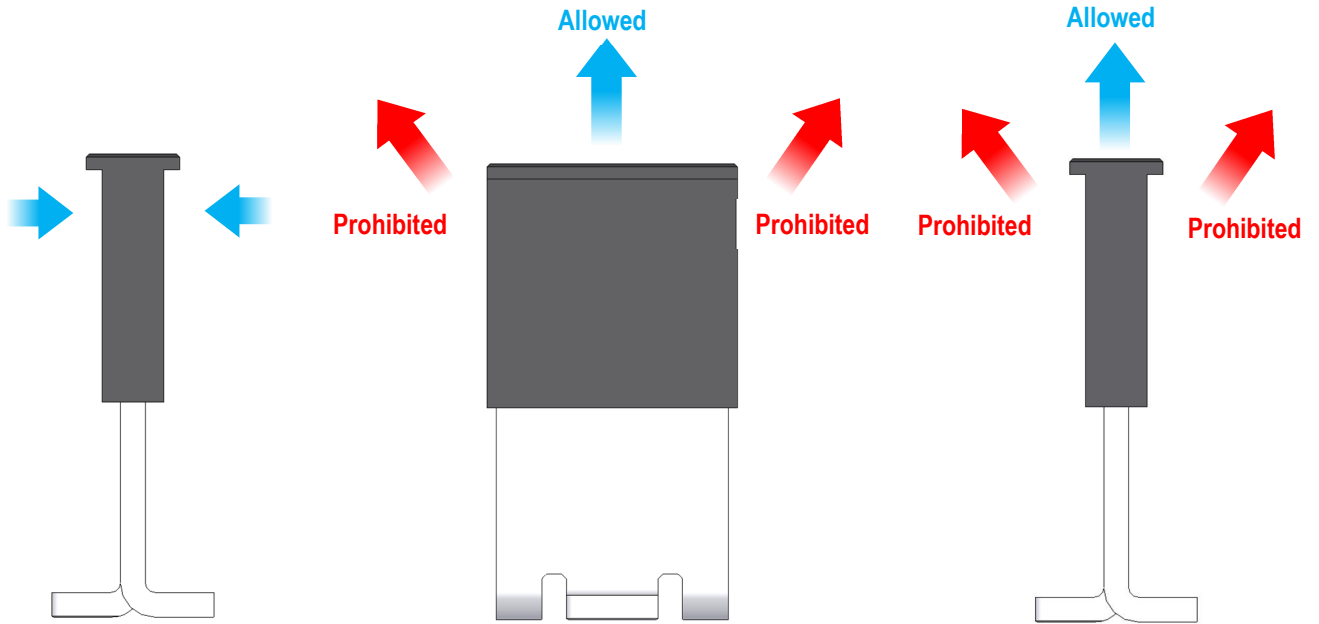

Fig.8 CAP holding area

Fig.9 CAP pick up direction

## 【RECEPTACLE CAP handling point】

When remove the CAP, hold side surface of the RECEPTACLE CAP and pick up the CAP vertically from the PCB surface.

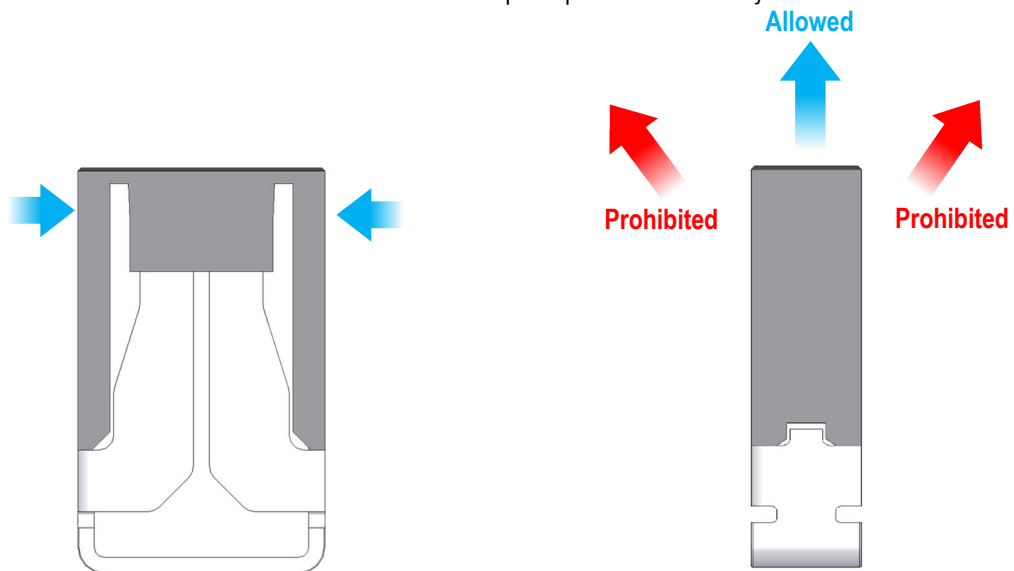

Fig.10 CAP holding area

Fig.11 CAP pick up direction

【Precaution for PLUG insertion】

1. Insertion procedure
2. Misalignment
3. Definition of misalignment in X-axis direction
4. Mating height

1. Insertion procedure

Place the plug to the receptacle guide as Fig.12. In the aligning, control the misalignment between receptacle and plug centers to be within the guaranteed misalignment range.

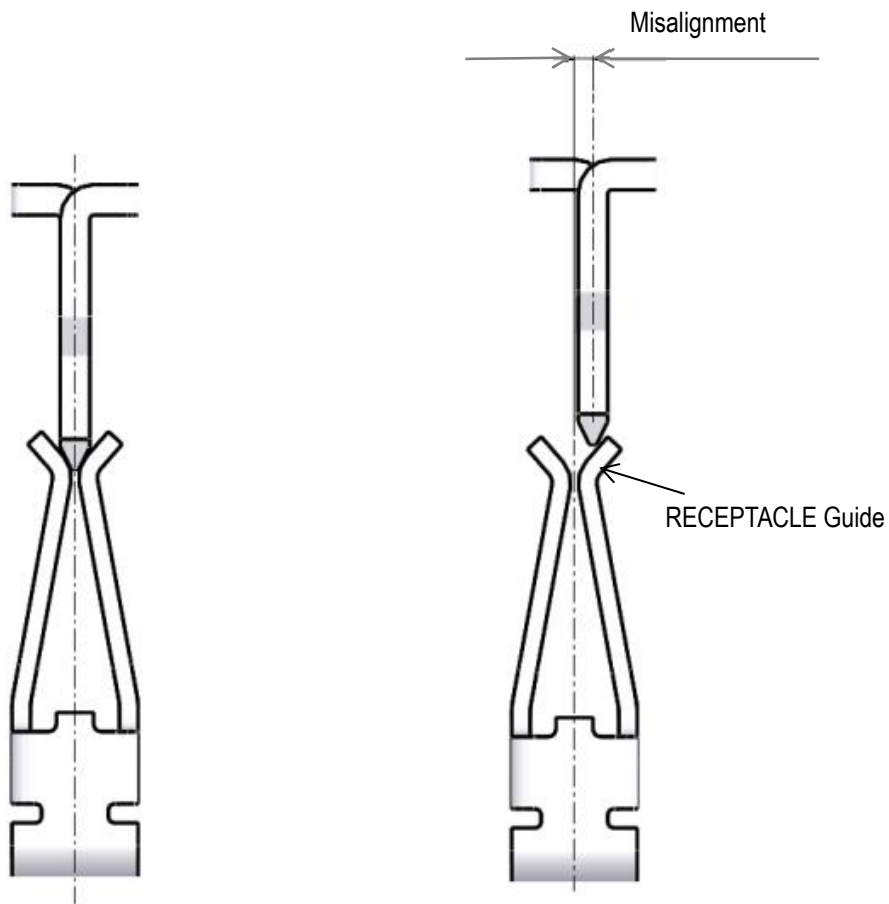
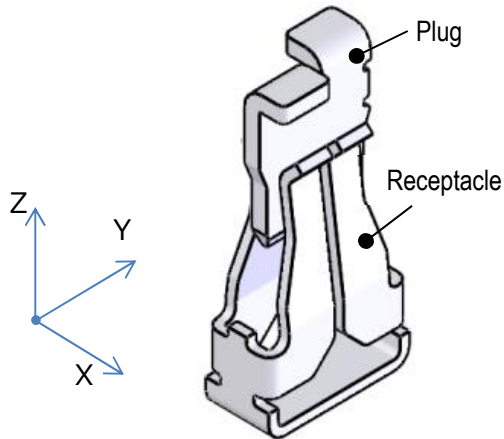

Fig. 12 Insertion procedure

## 2. Misalignment

### 2-1. About the X, Y, and Z directions



### 2-2. Misalignment allowance in Y-axis direction

The misalignment in Y-axis direction should be within the range where the RECEPTACLE spring ends do not extend beyond the both ends of the PLUG area.

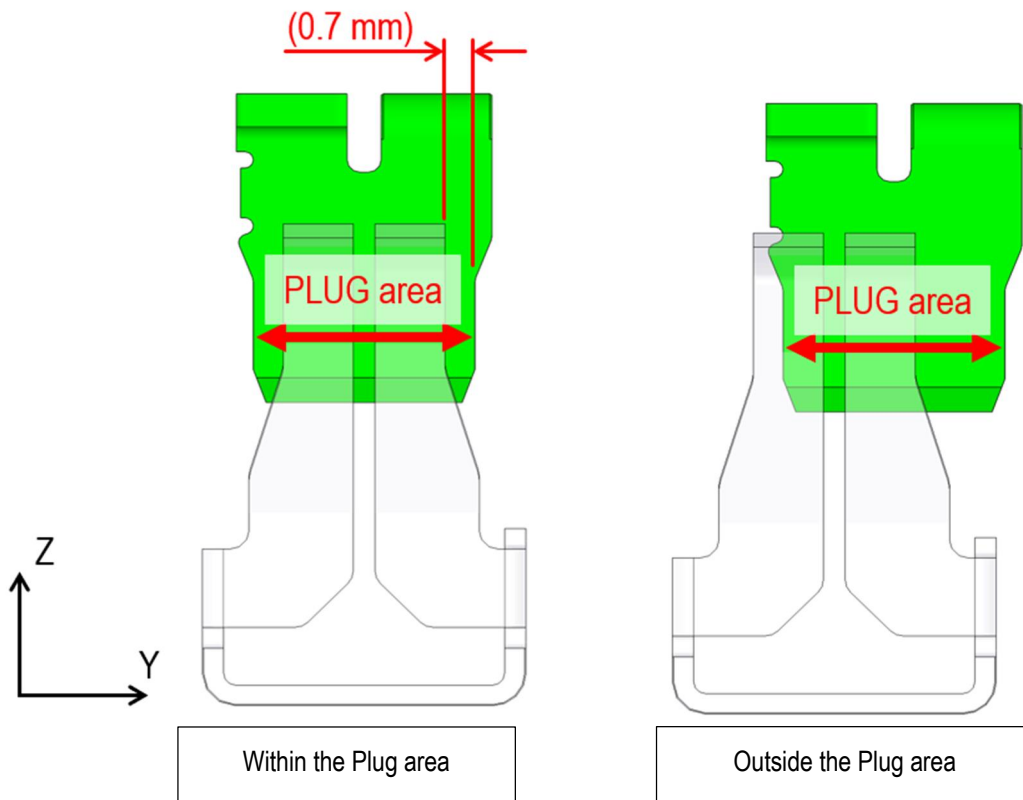

## 2-3. Misalignment allowance in X direction

- 1) Misalignment at the initial insertion is 0.55mm. Control the insertion misalignment between initial insertion position and re-insertion position to be within 0.45mm. (See Fig.13, re-insertion condition.) The misalignment allowance in X direction has been set considering the production tolerance.
- 2) Connection other than the contact position is out of our warranty when mating Plug and Receptacle connector.

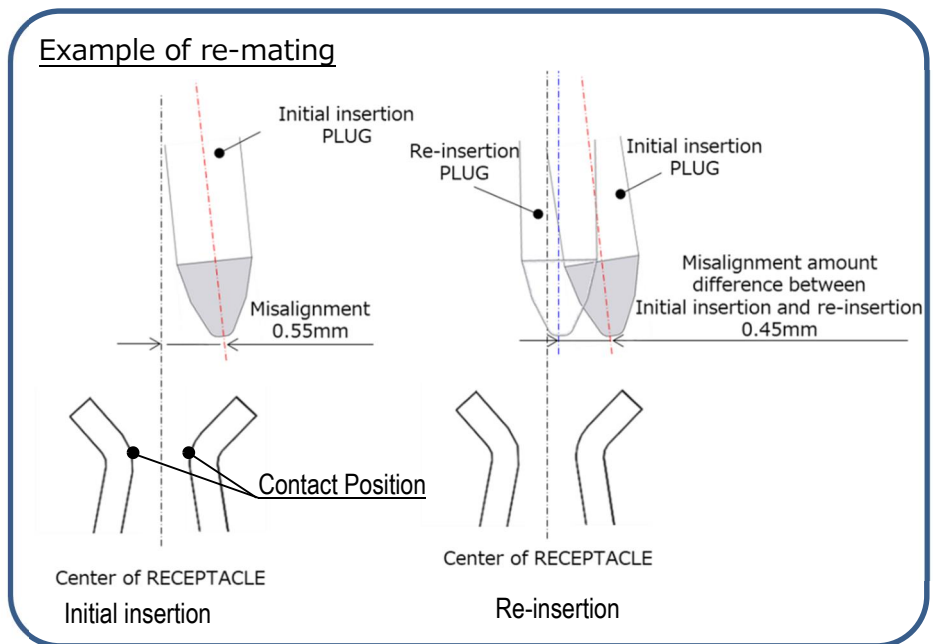
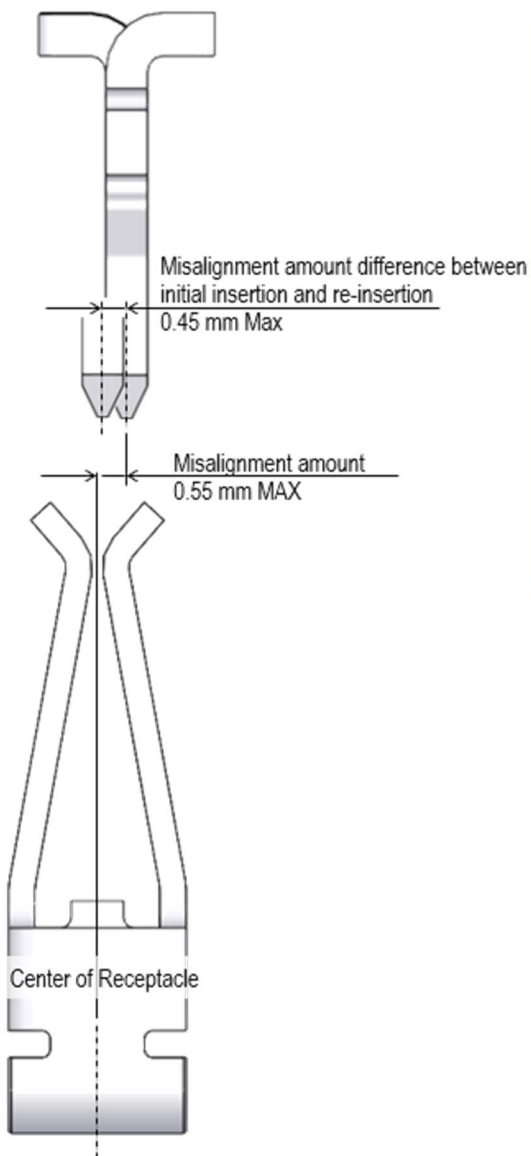

Fig.13 Condition of re-insertion

3. Definition of misalignment in X-axis direction

The amount of axis deviation is the sum of the offset amount X [mm] and the deviation components [A], [B], and [C] in the x-axis direction.

Misalignment :  $X + [A] + [B] + [C]$

[E.g.]  $X + [A] + [B] + [C] = 0.4 \text{ mm} + 0.1 \text{ mm} + 0.02 \text{ mm} + 0.05 \text{ mm} = 0.57 \text{ mm} \rightarrow \text{NG}$

$X + [A] + [B] + [C] = 0.35 \text{ mm} + 0.12 \text{ mm} + 0.02 \text{ mm} + 0.03 \text{ mm} = 0.52 \text{ mm} \rightarrow \text{OK}$

The misalignment components [A], [B], and [C] are defined below. (See Fig. 6)

[A] : Displacement amount of the contact point in axis x direction caused by PLUG rotation

angle  $\theta \dots 1.90\text{mm (RECEPTACLE spring area)} \cdot \tan\theta$

[B] : Amount of displacement that increases in the x-axis direction of the contact part when

Y is offset in the y-axis direction with PLUG rotated by  $\theta \dots Y \cdot \tan\theta$

[C] : Displacement amount of point W in x axis direction with the plug leaning  $\dots (AP-10 \text{ PLUG height}) \cdot \sin\phi$

( $\theta$  [deg] : PLUG rotation angle, Y [mm] : Misalignment in axis y direction,  $\phi$  [deg] : PLUG leaning angle)

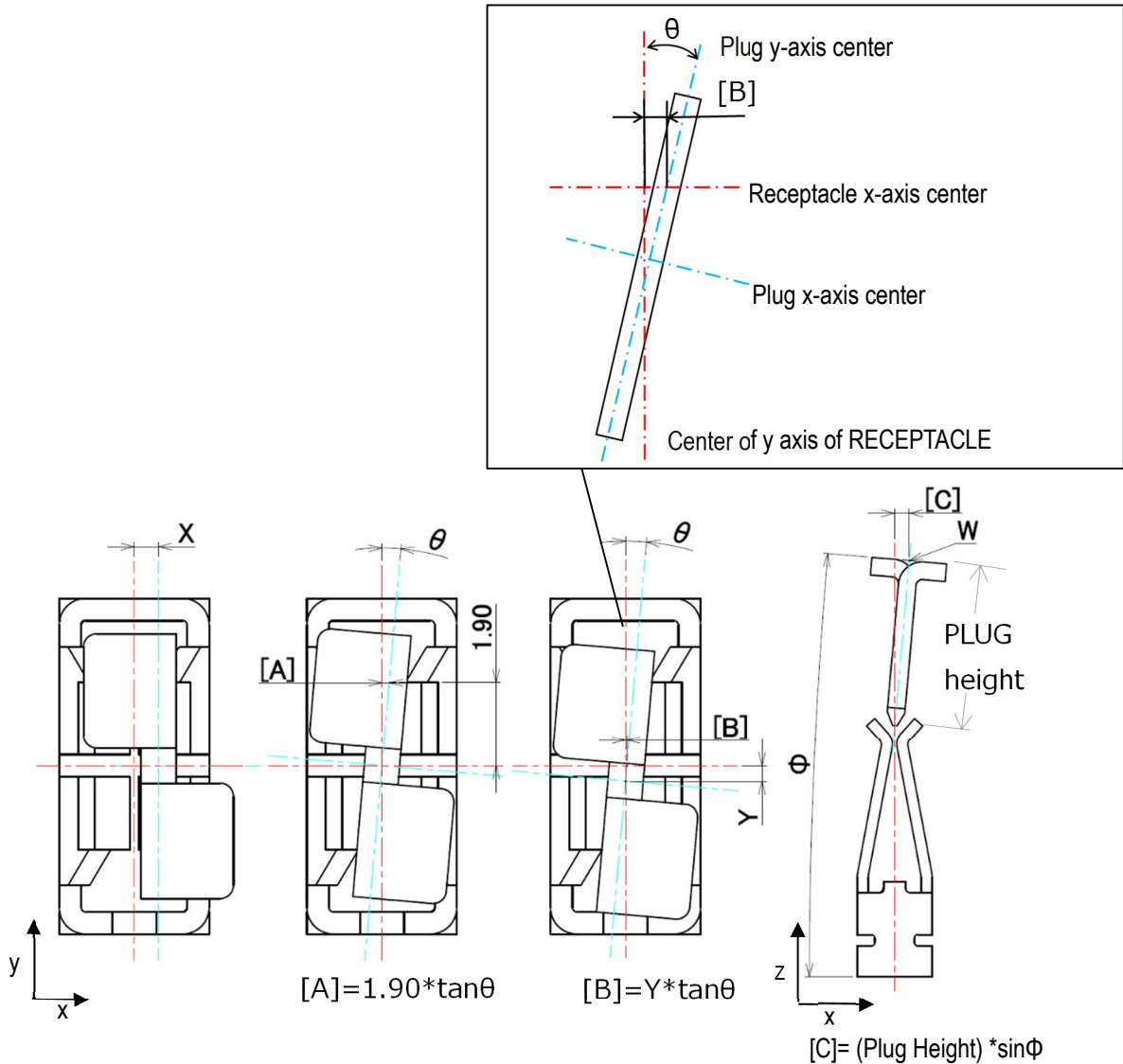

Fig.14 Misalignment component



## 4. Mating height

Insert PLUG vertically and use the mating height within the range shown in Fig.15.

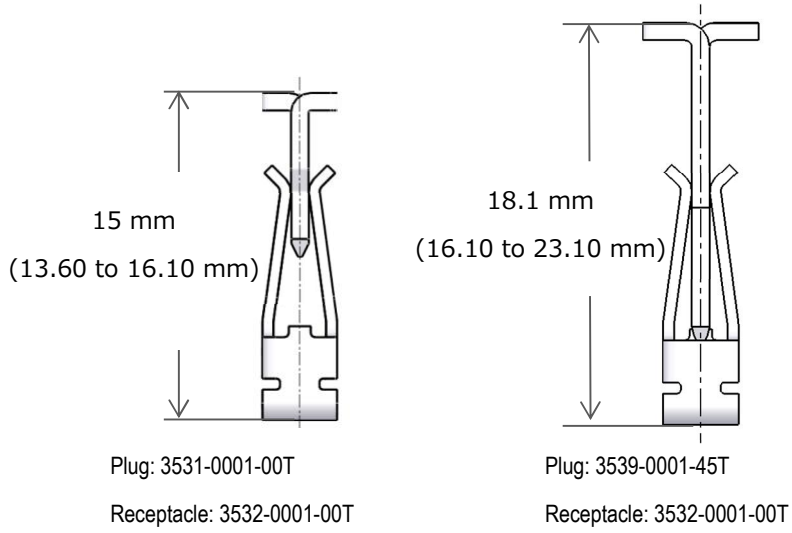

Fig.15 Mating Height