

FPL™ II PLUG

Part No. 20437

Assembly Manual

3	S24237	June 10, 2024	E.Tanaka	M.Nakamura	T.Masunaga
2	S23311	September 27, 2023	H.Uchida	M.Nakamura	T.Masunaga
1	S14518	December 17, 2014	K.Tsusu	-	J.Tateishi
0	S12055	February 7, 2012	H.Aoki	J.Tateishi	T.Harada
Rev.	ECN	Date	Prepared by	Checked by	Approved by

1. Purpose :

This manual explains the soldering method and assembly processes of the FPL II CONNECTOR PLUG with shell-A.

2. Applicable Connector :

Name: FPL II CONNECTOR PLUG

Parts No. :

Type	For AWG#32~#40
Cable Assembly	20437-#**T-*1
Housing Assembly	20438-#**T-*1
Shell-A	2496-0**

3. Recommended use of Tool Equipment :

- Pulse Heater : Nippon Avionics Co., Ltd.

Products Name	Products No.
Pulse Heat Generator	TCW-215
Reflow Head	NA-66

- Heater Tip

Pressure: 9.8N (1.0 kgf)

【Size】Thickness: 0.6~0.8 mm

Width:

Positions	Dimension of Heater Tip [mm]
For AWG#32~#40	A
30P	15.5±0.2
40P	20.5±0.2
50P	25.5±0.2

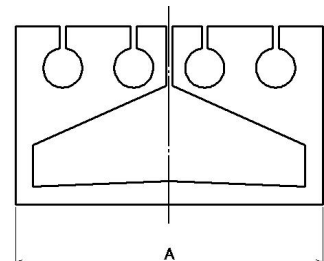

- Solder Bar

(Recommended) $\phi 0.15$ mm (resin-cored solder) is pressed and used.

Positions	Length of Solder Bar [mm]
For AWG#32~#40	
30P	15.5±0.2
40P	20.5±0.2
50P	25.5±0.2

- Soldering Iron 50W

4. Recommended Pulse Heat Condition

① Idle Temp.	:	150 °C
② 1 st Heat Temp.	:	230 °C
③ " Rise Time	:	0.5sec.
④ " Holding Time	:	2.0sec.
⑤ 2 nd Heat Temp.	:	325 °C
⑥ " Rise Time	:	0.5sec.
⑦ " Holding Time	:	3.0sec.

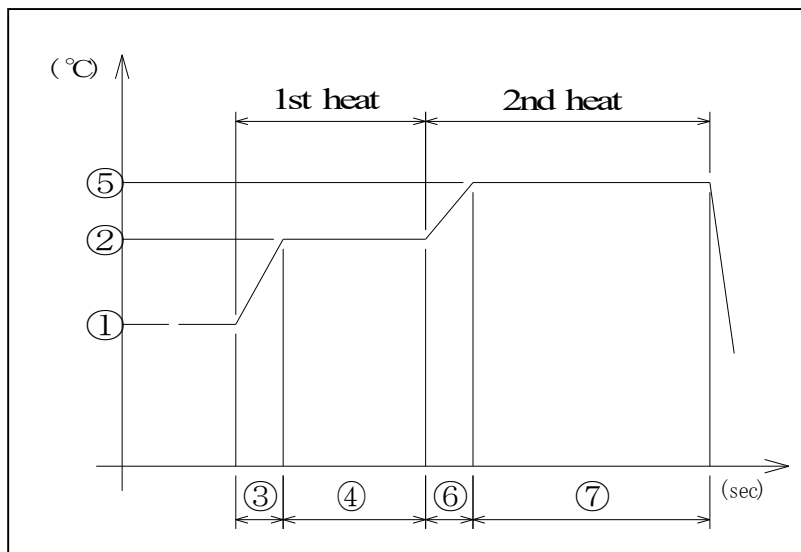

*This pulse heat condition was evaluated and confirmed by our pulse heat jig and instruments. The most optimum condition may change based on the shapes of pulse heat jig and instruments, the environments, or other reason.

Therefore, please examine the pulse heat condition adequately in advance of use.

5. Work Procedures :

5-1. Soldering of Center-Conductor

① The cables have to be fabricated as shown below in advance of soldering.

POS.	A	E
30	14.50	17.50
40	19.50	22.50
50	24.50	27.50

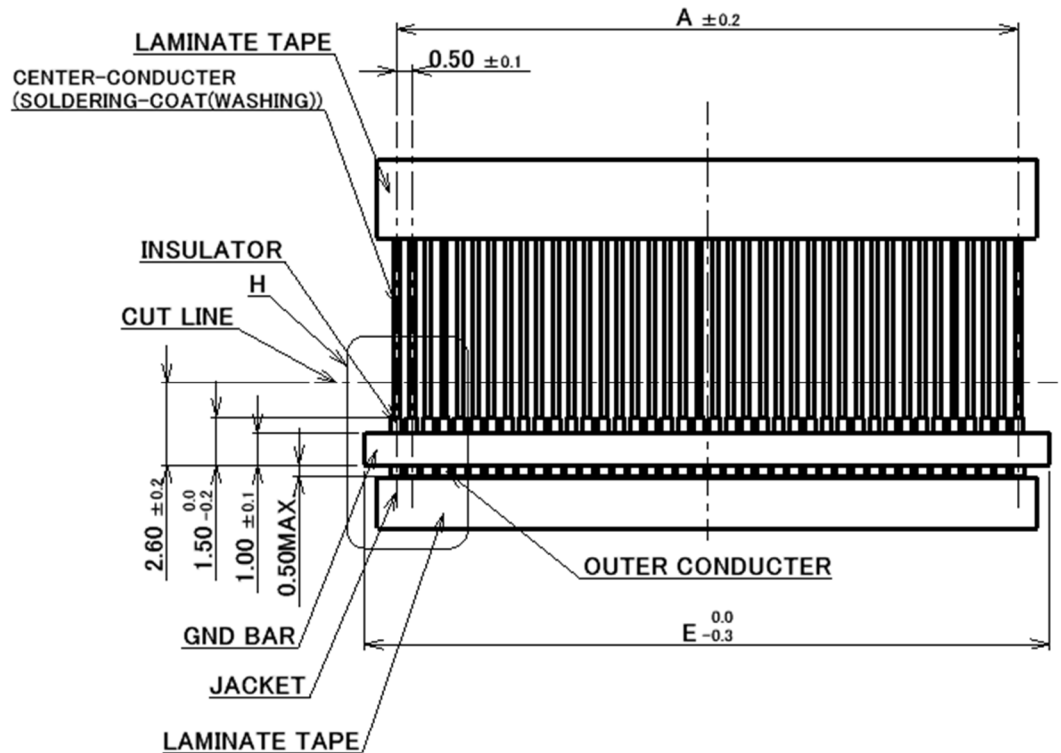

Recommended Micro-Coaxial Cable Dimensions

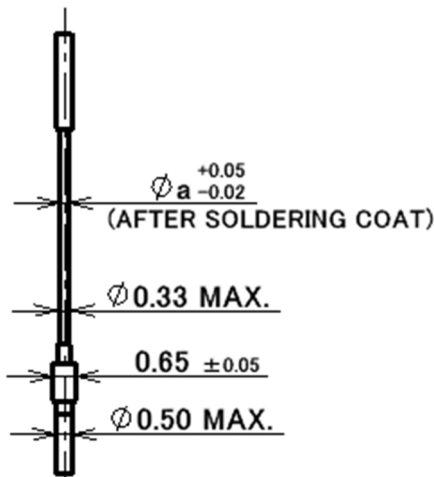

Micro-Coaxial Cable AWG#**

Characteristic Impedance Matching Micro-Coaxial Cable

	a
#36	0.15
#38	0.12
#40	0.09

Characteristic Impedance Un-Matching Micro-Coaxial Cable

	a
#32	0.24
#34	0.192

Micro-Coaxial Cable #32, 34: Not Recommended for
High Speed Signal Transfer

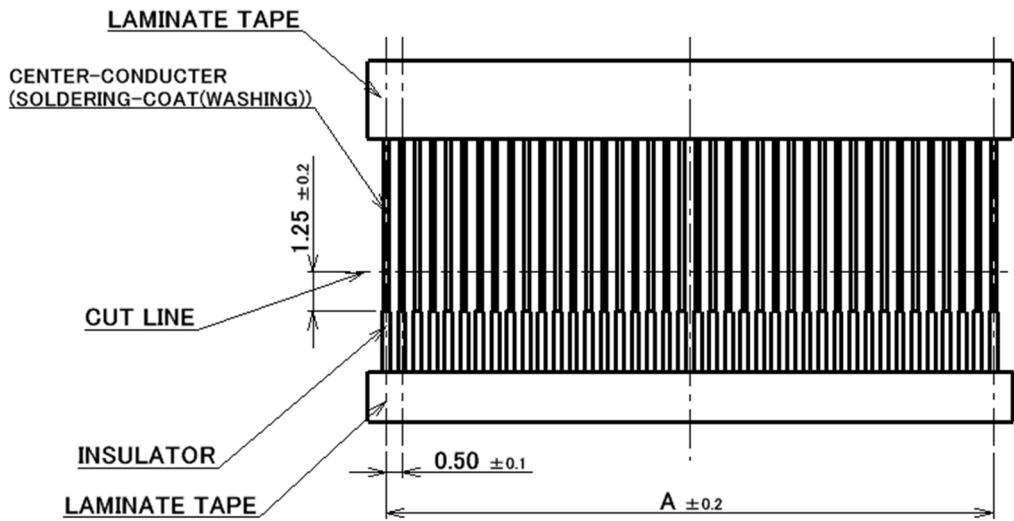

Recommended Discrete Wire Dimensions

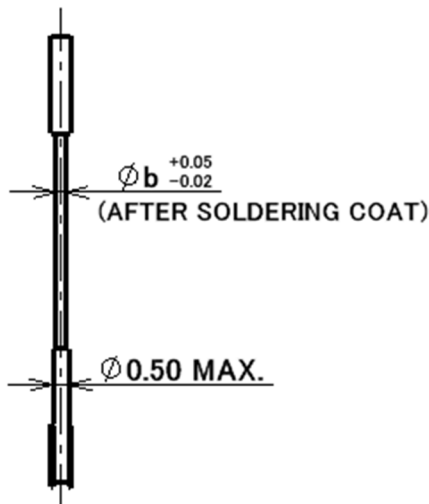

Discrete Wire AWG#**

Discrete Wire Dimensions

	b
#32	0.24
#34	0.192
#36	0.15

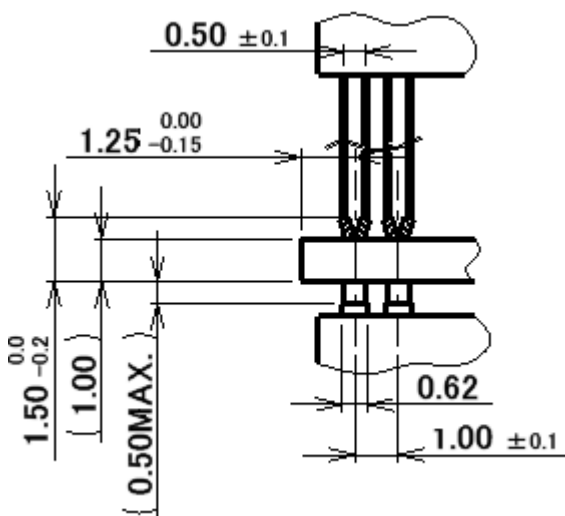

Recommended Twinax Cable Dimensions

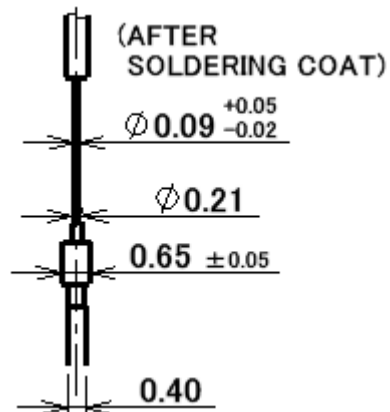

Twinax Cable AWG#40

② Set the solder bar on the connector.

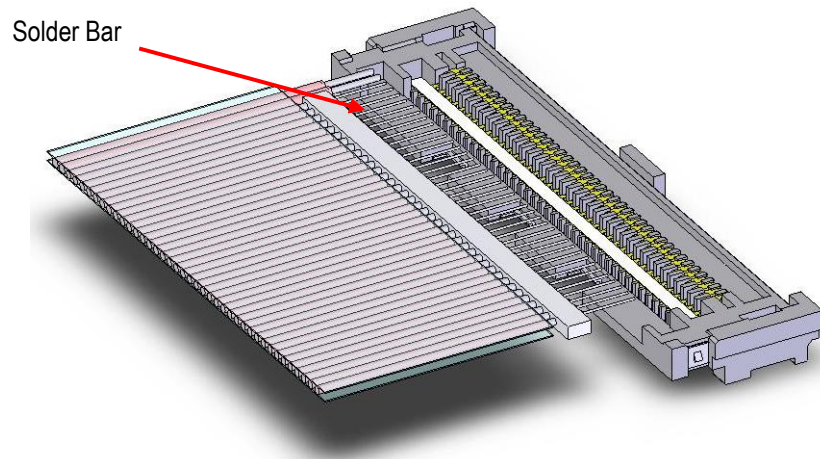

Fig.1 Set of Solder Bar

③ Set the cable.

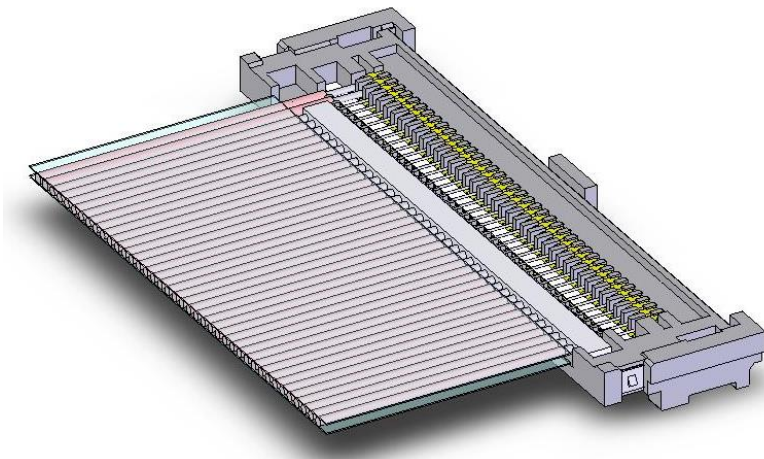

Fig.2 Set of Cable

④ Center-conductors are soldered with pulse heater. See Fig .3 of soldering condition.

Set of discrete cable is to protect 0.5 mm MAX. as below. There is danger that center-conductor touch the ground shell-A.

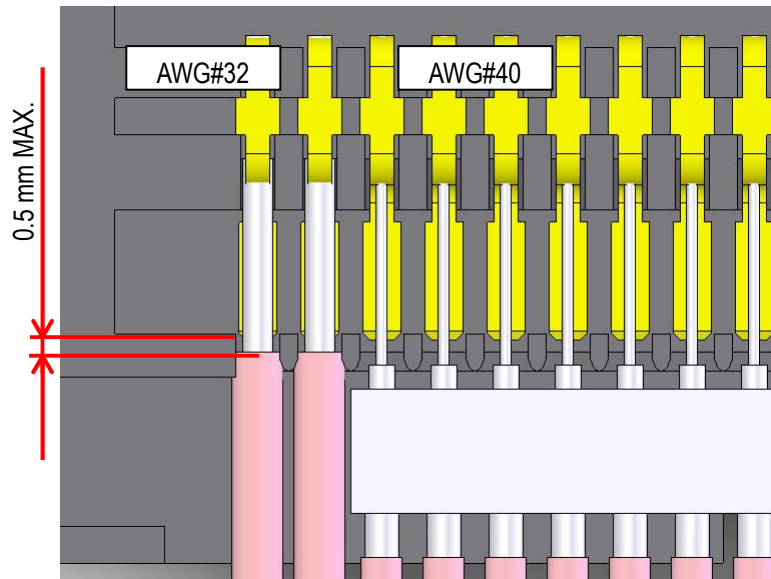

Fig.3 AWG#32, #40

*When solder bridge is appeared between the terminal, try heating again with pulse heater only one time.

If the bridge isn't repaired, use the soldering iron only the failure point.

Condition of Soldering Iron : 50W

Operating Temperature : 350 °C

Application Time of Soldering Iron : Within 5sec.

5-2. Cautions in Treating Shell-A

Shell-A is delivered in the reel with a carrier.
The following is the method to cut shell-A from carrier.

- ① Cut carrier on the cut line of the left below picture (green line) by a scissors for metal.

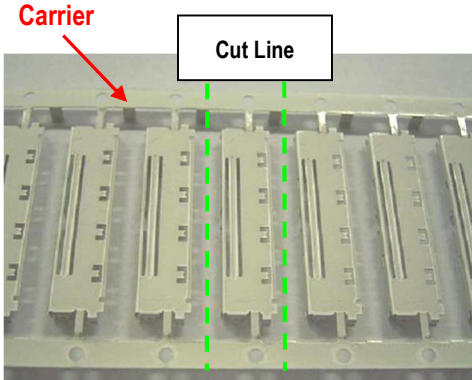

Photo.1. Before Cut

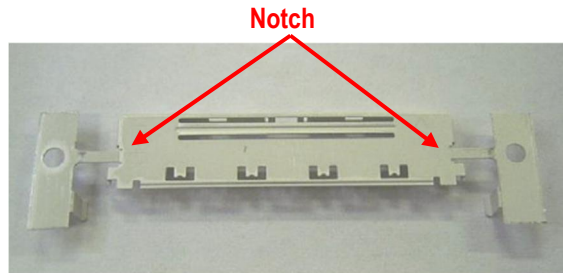

Photo.2. After Cut

Plug Shell-A Detail of Notch

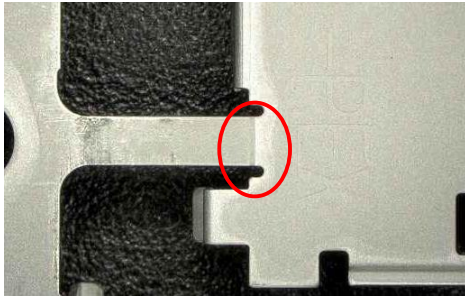

Photo.3. Upper Side View

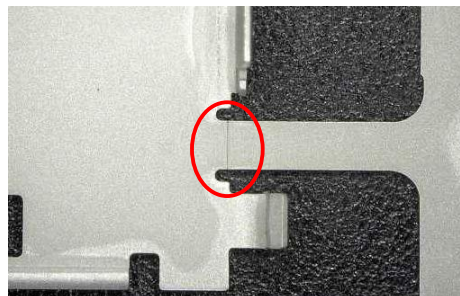

Photo.4. Bottom Side View

- ② Hold the center of plug shell-A and cut it off from notch by ± 45 deg of reciprocating work.
When it does not be cut, try again this reciprocating work. After separated, check there is no burr around the cut part. (Photo.6)

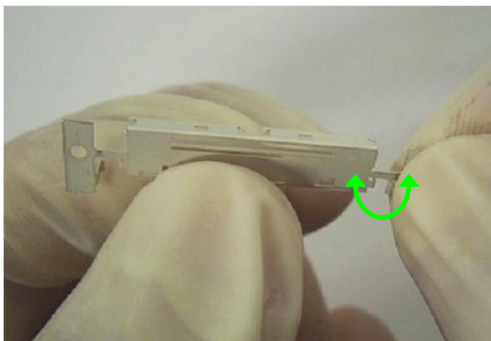
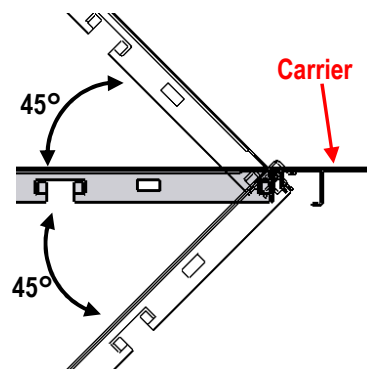

Photo.5. Cut Condition



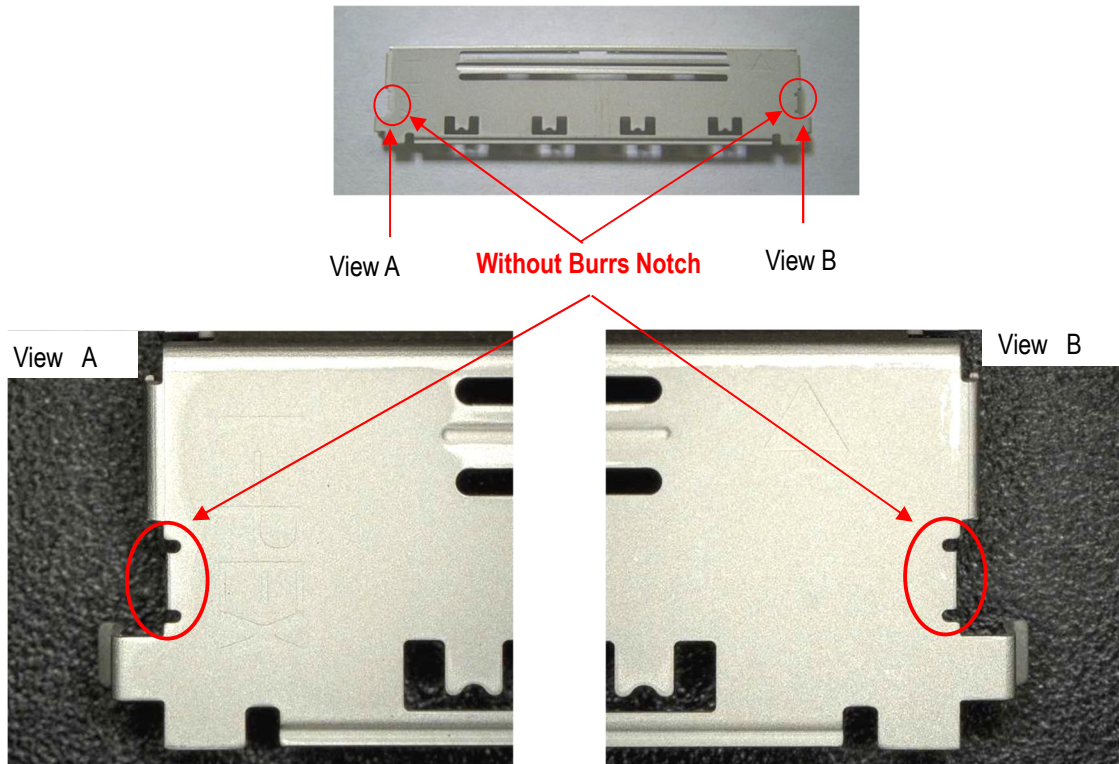

Photo.6. After Cut

Caution: By pulling like the photo below to cut off by force (red arrow direction), burrs and deformation can be caused.

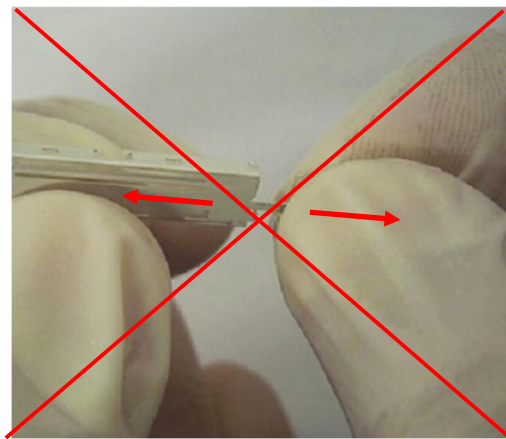

Photo.7. Cut by Force (Bad Example)

5-3. Assembly of Shell-A

- ① Pull tape is got in shell-A.

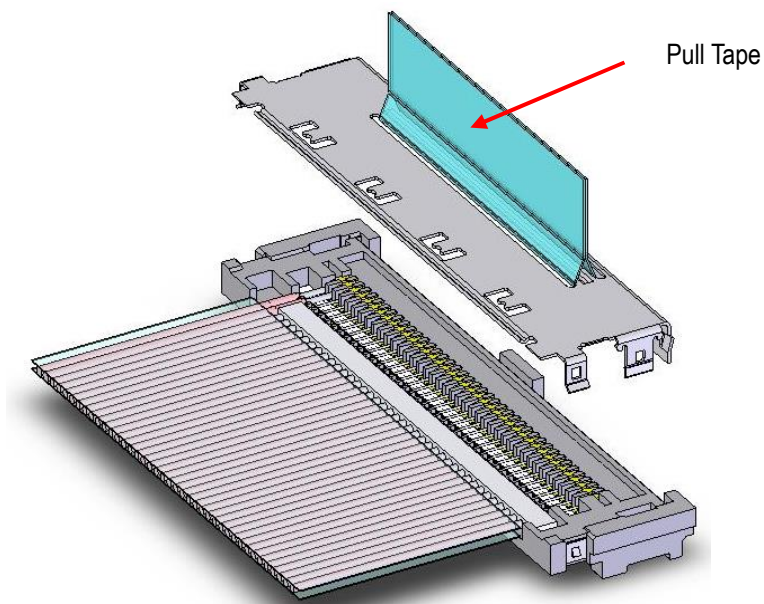

Fig.4 Assembly Pull Tape

- ② Temporary sets shell-A. See Fig.5.

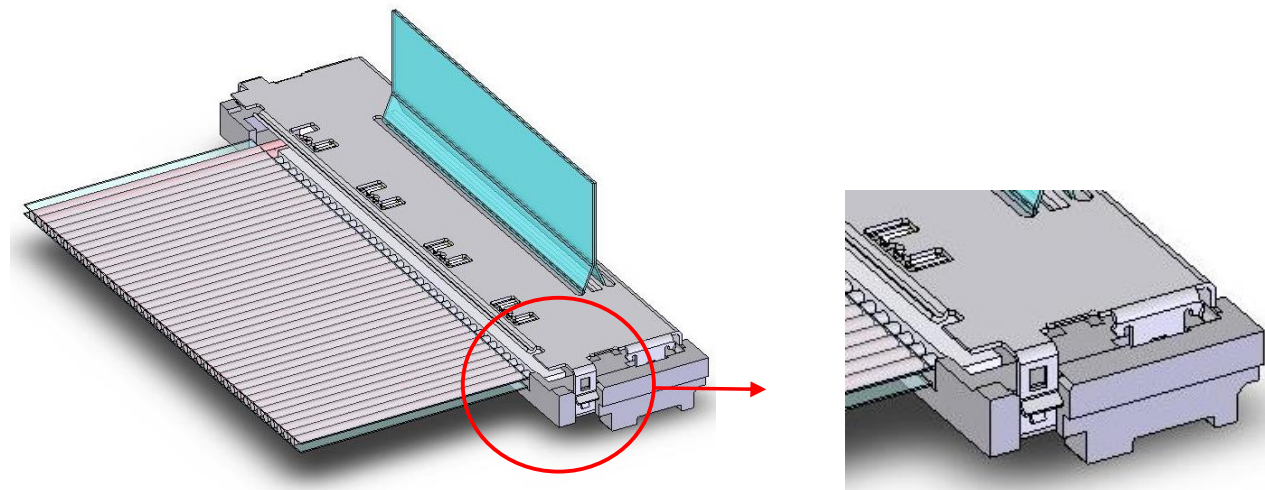

Fig.5 Temporary Sets Shell-A

③ The ○ part (see Fig.6) of shell-A is pushed and inserted.

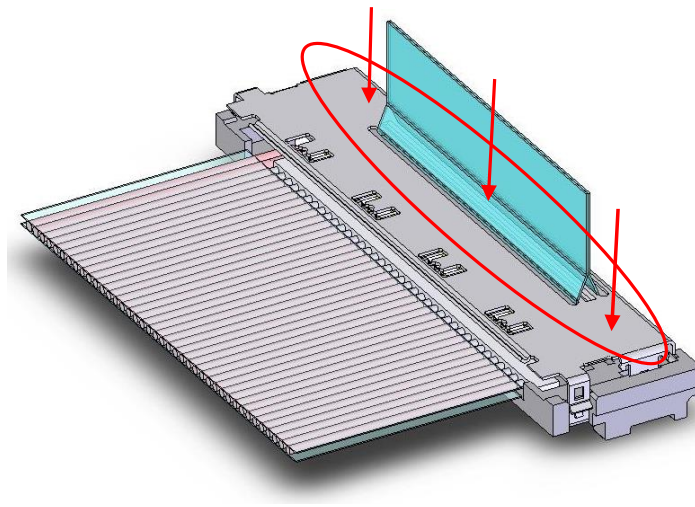

Fig.6 Insert of Shell-A (Correct)

【Attention】

Don't push the ○ part (see Fig.7) when insert shell-A. It may not be able to be assembled normally.

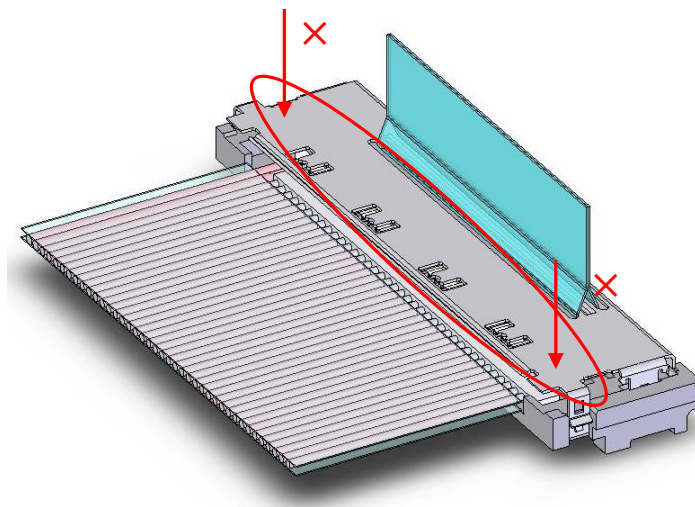

Fig.7 Insert of Shell-A (Incorrect)

④ It confirms whether shell-A is being inserted normally.

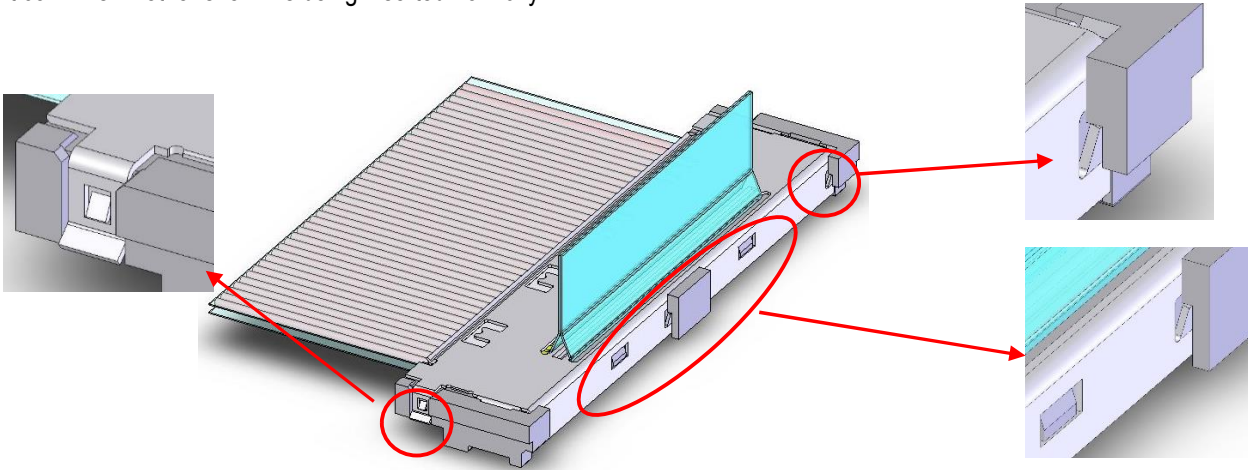

Fig.8 The Insertion Confirmation of Shell-A

5-4. Fixation of the Cable and Shell-A, Shell-B

The □ part (Fig.9) of shell-A, shell-B is soldered to ground bar.

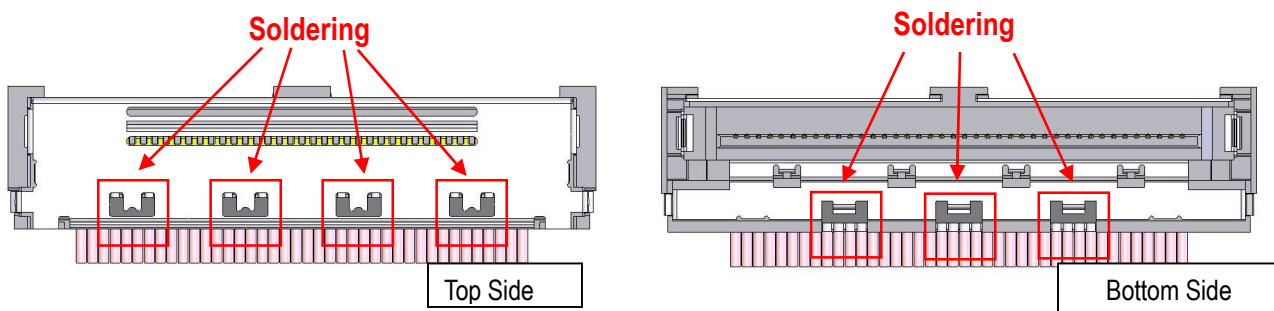

Fig.9 Soldering Shell-A, Shell-B

The cable terminal part and shell-A, shell-B are fixed with the bond.

Recommended bond: LOCTITE352

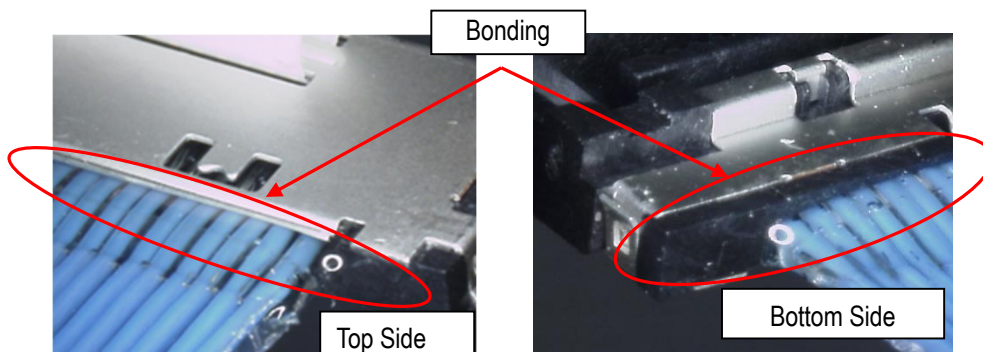

Photo.8 Bonding