

Recommended P/N 20864-010E-01

PART NO.	Pos.
20864-010E-01	10

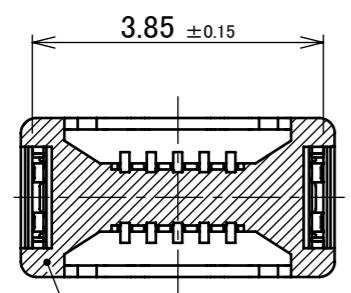

There is a possibility of dent shape in the bottom surface of HOUSING.

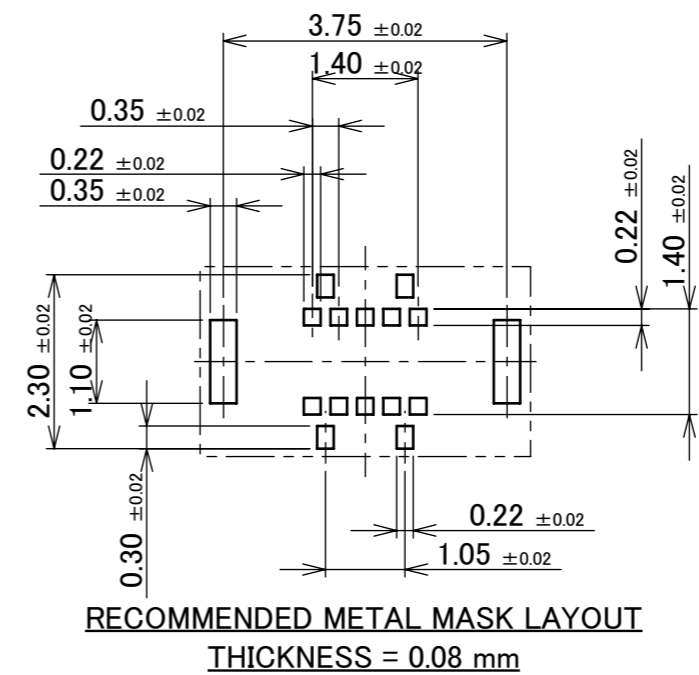
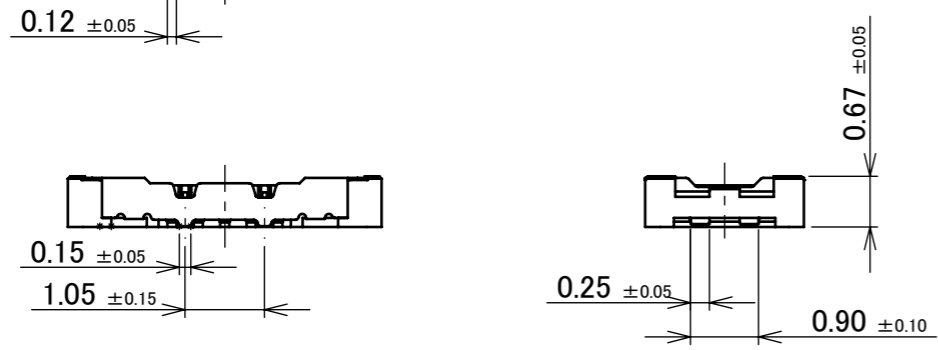
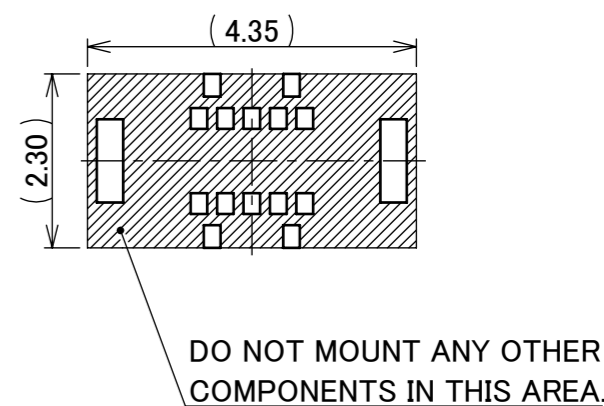
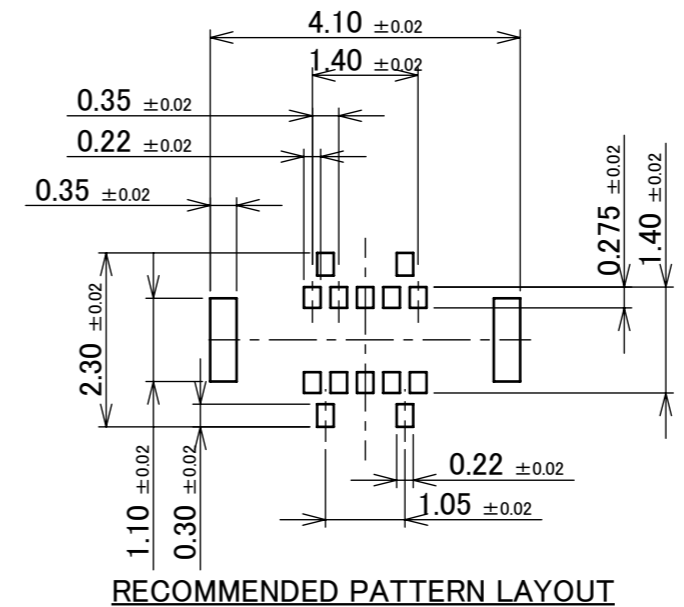
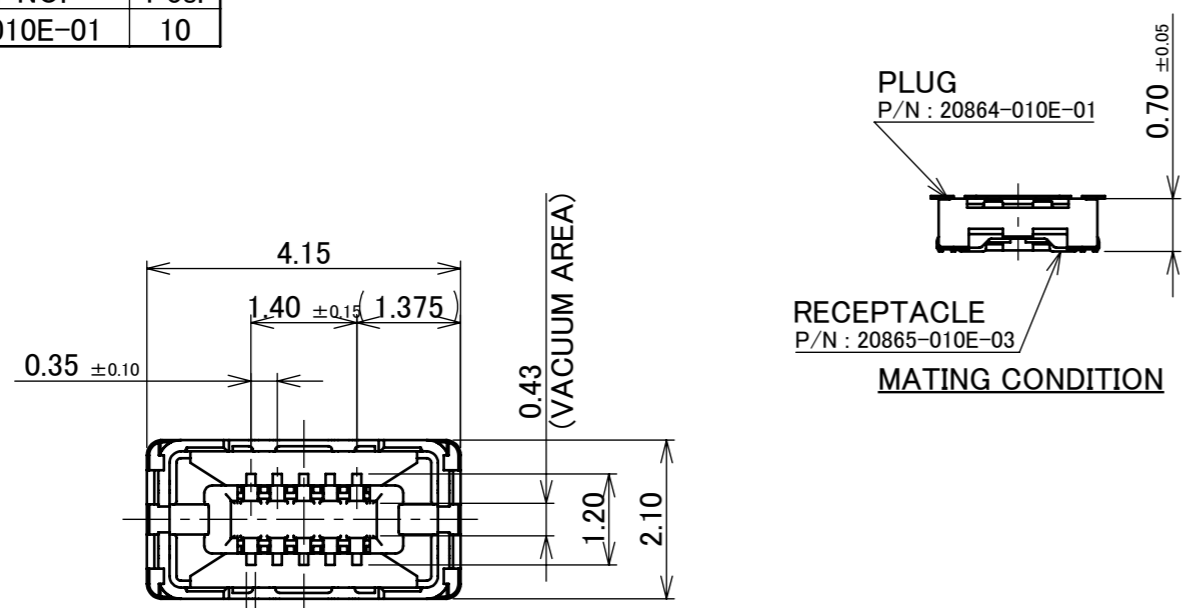
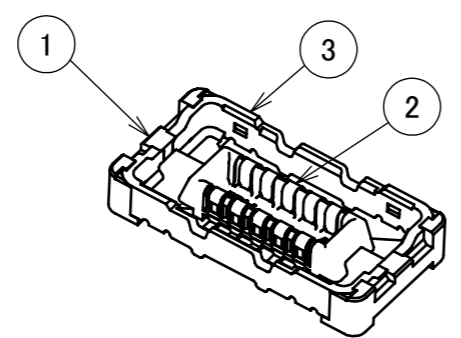

3	SHELL	COPPER ALLOY	SOLDERING PART Au 0.01 μm MIN. OVER Ni 1.27 μm MIN.	
2	CONTACT	COPPER ALLOY	CONTACT PART Au 0.05 μm MIN. OVER Ni 1.27 μm MIN. SOLDERING PART Au 0.01 μm MIN. OVER Ni 1.27 μm MIN.	
1	HOUSING	LCP	UL94V-0, BLACK	
NO.	DISCRIPTION	MATERIAL	FINISH, REMARKS	
10	Z241128	Moto	2024/08/27	S.S
9	Z220201	TSU	2022/02/25	Y.H
8	Z201019	M.H	Oct./02/'20	Y.H
7	Z191631	Tad	Dec./16/'19	Y.S
6	Z191609	Tad	Dec./10/'19	Y.S
5	Z190899	Tad	Jul./09/'19	Y.S
REV.	ECN	BY	DATE	APP.
REVISION RECORD				
		K.Yotsutani		2018/01/12
		DWG. No.		20864
		SERIES No.		R2
		PROJECTION		
		TITLE		NOVASTACK® 35-HDN PLUG ASSEMBLY
		SCALE		10:1
		UNIT		mm
		SIZE		A3
		SHEET		1/6
		REV.		10
		CUSTOMER COPY		

Recommended P/N 20864-020E-01

PART NO.	Pos.
20864-020E-01	20

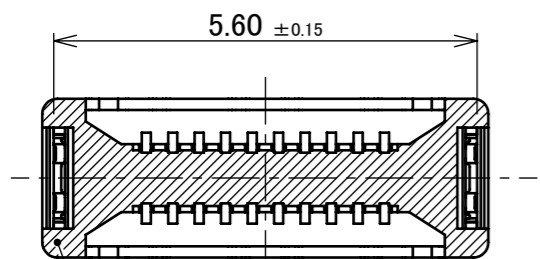
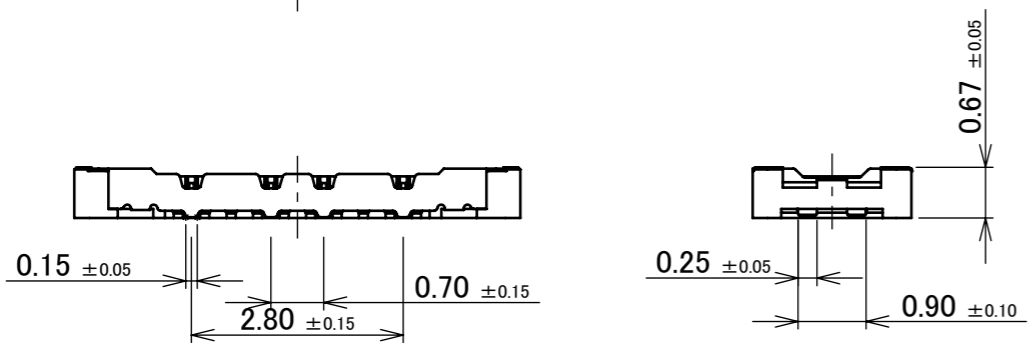
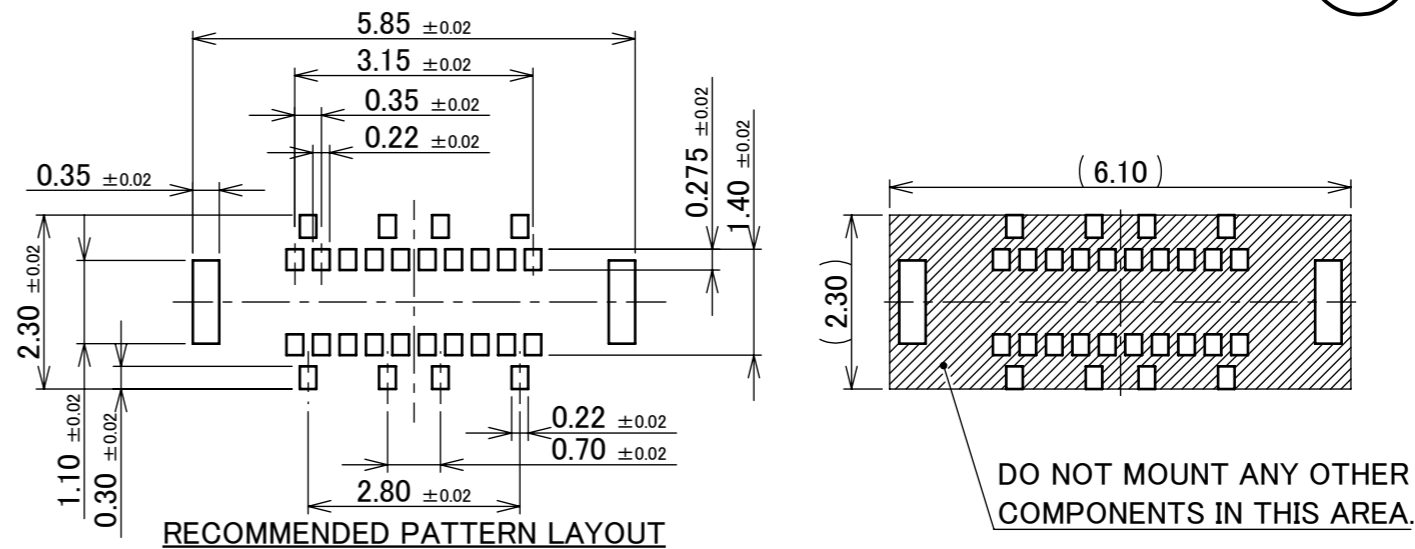
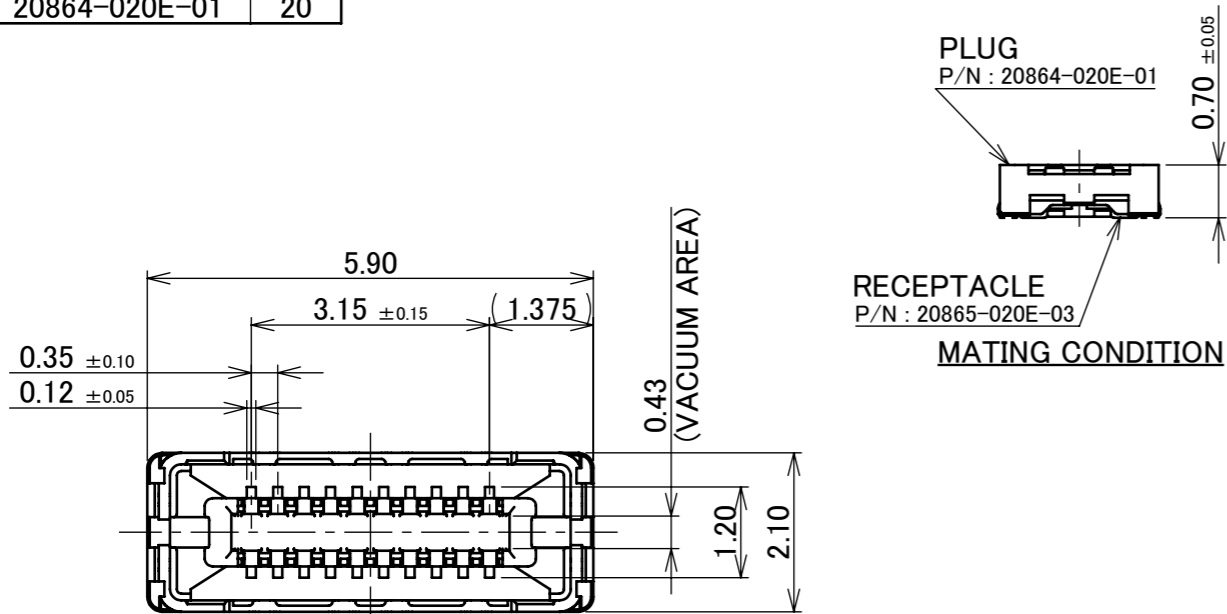

There is a possibility of dent shape in the bottom surface of HOUSING.

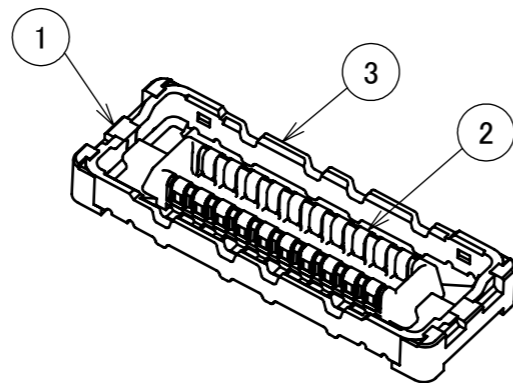

3	SHELL	COPPER ALLOY	SOLDERING PART Au 0.01 μm MIN. OVER Ni 1.27 μm MIN.
2	CONTACT	COPPER ALLOY	CONTACT PART Au 0.05 μm MIN. OVER Ni 1.27 μm MIN. SOLDERING PART Au 0.01 μm MIN. OVER Ni 1.27 μm MIN.
1	HOUSING	LCP	UL94V-0, BLACK
NO.	DISCRIPTION	MATERIAL	FINISH, REMARKS

ANGLE	±2°	6 OVER 30 MAX.	±0.3	PROJECTION ⊕	SERIES No. R2	CUSTOMER COPY		
	6 MAX.	±0.2	30 OVER 120 MAX.				±0.5	
GENERAL TOLERANCE.				TITLE NOVASTACK® 35-HDN PLUG ASSEMBLY	SCALE 10:1	UNIT mm		
DWG.	DATE							
CHK.								
APP.								
				DWG. No.	20864	SIZE A3	SHEET 2/6	REV. 10

Recommended P/N 20864-030E-01

PART NO.	Pos.
20864-030E-01	30

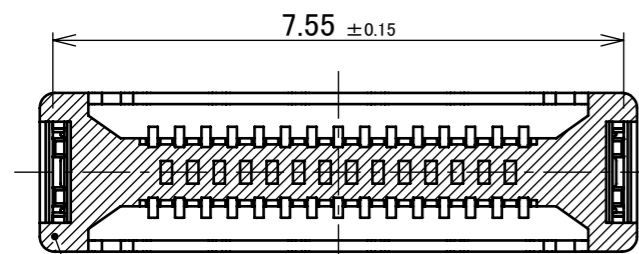
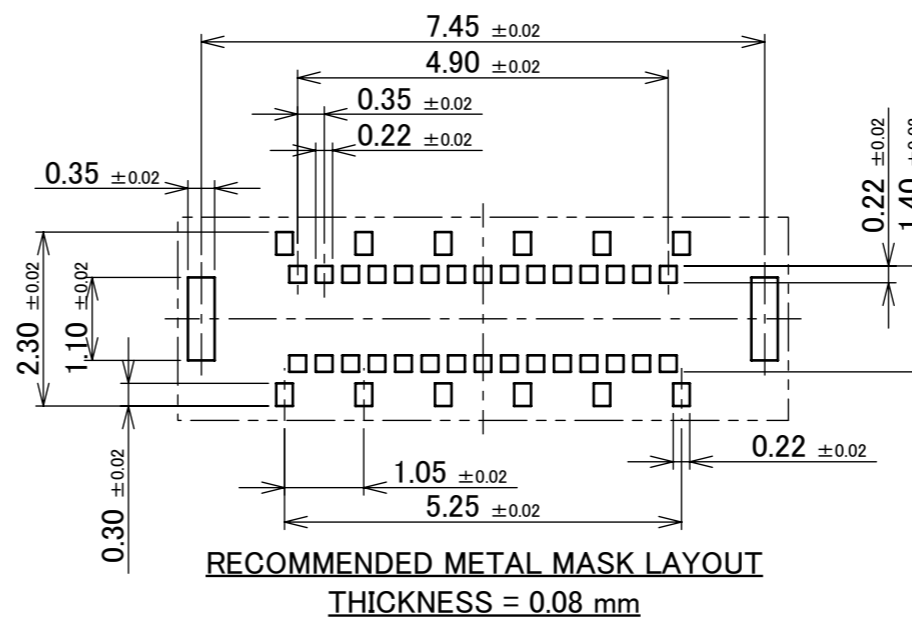
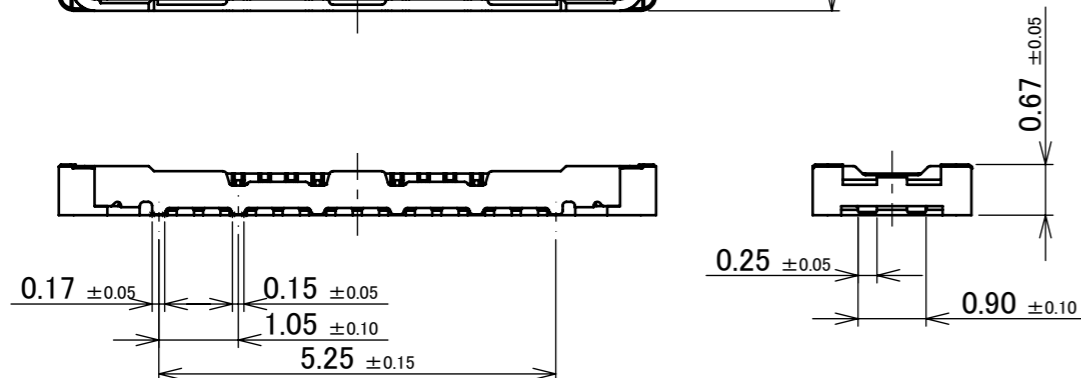
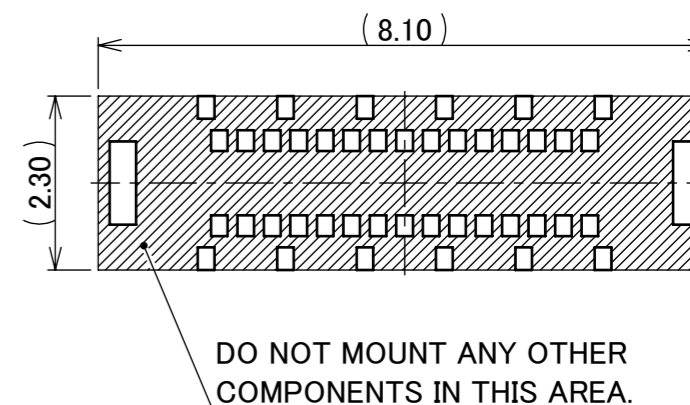
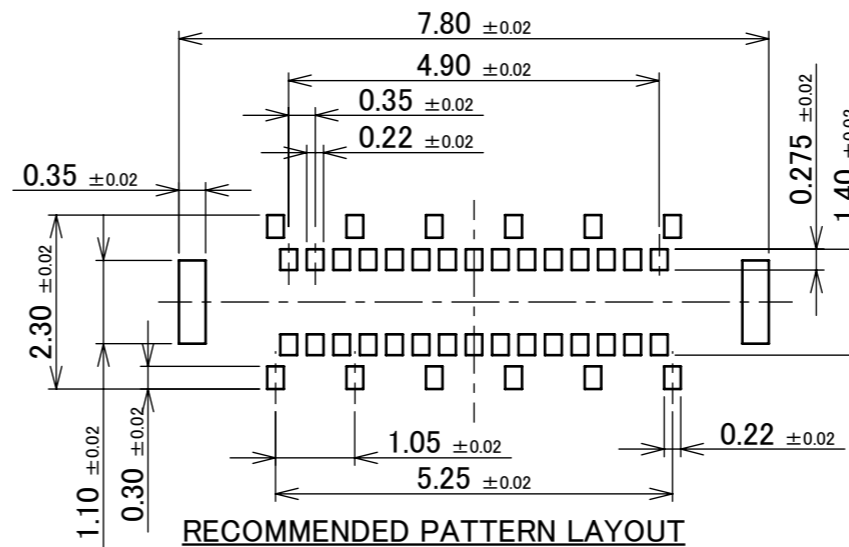
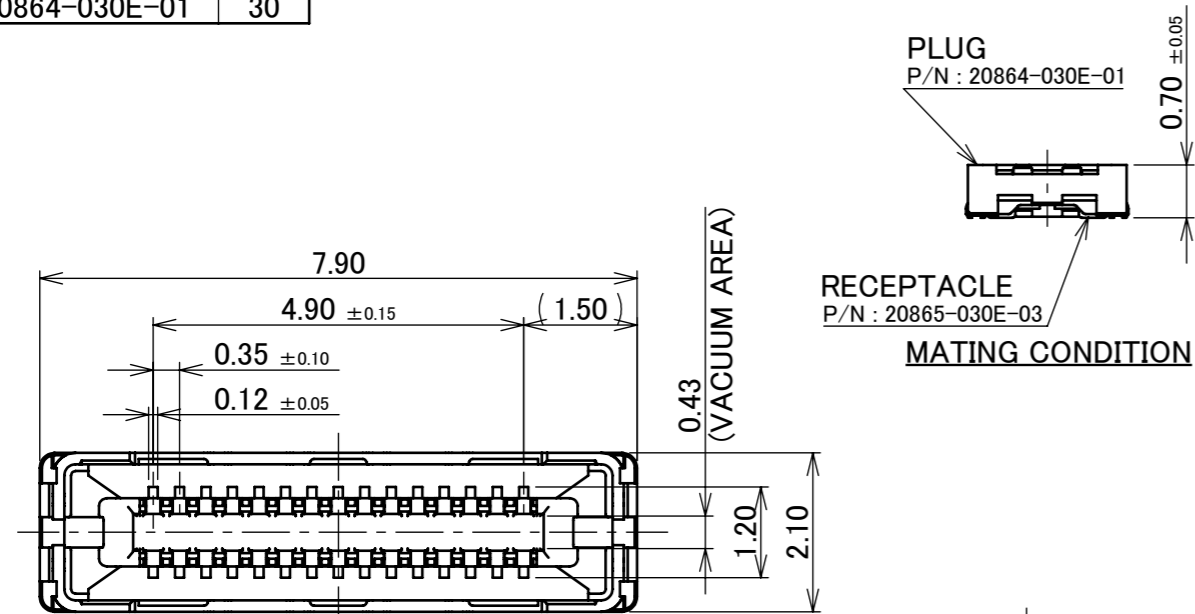

There is a possibility of dent shape in the bottom surface of HOUSING.

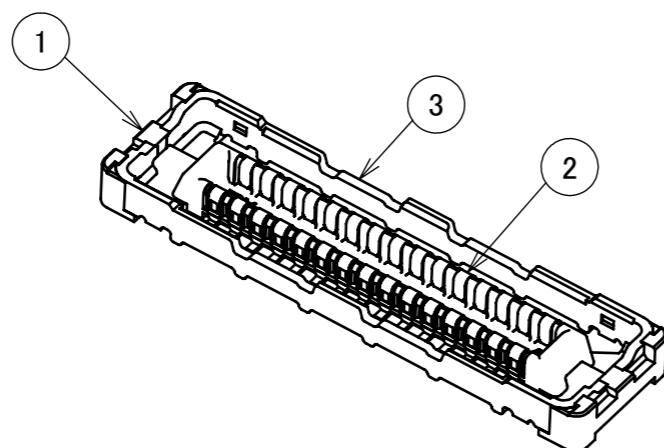

3	SHELL	COPPER ALLOY	SOLDERING PART Au 0.01 μ m MIN. OVER Ni 1.27 μ m MIN.
2	CONTACT	COPPER ALLOY	CONTACT PART Au 0.05 μ m MIN. OVER Ni 1.27 μ m MIN. SOLDERING PART Au 0.01 μ m MIN. OVER Ni 1.27 μ m MIN.
1	HOUSING	LCP	UL94V-0, BLACK
NO.	DISCRIPTION	MATERIAL	FINISH, REMARKS

ANGLE	±2°	6 OVER 30 MAX.	±0.3	PROJECTION ⊕	SERIES No. R2	CUSTOMER COPY
	6 MAX.	±0.2	30 OVER 120 MAX.			
GENERAL TOLERANCE.				TITLE NOVASTACK® 35-HDN PLUG ASSEMBLY	SCALE 10:1	UNIT mm
DWG.	DATE					
CHK.						
APP.						
DWG. No. 20864				SIZE A3	SHEET 3/6	REV. 10

ITEMS	SPECIFICATION
APPLICABLE CONNECTOR PART No.	20865-0**E-**
RATING VOLTAGE	60V AC(r.m.s) / DC (PER CONTACT PIN)
RATING AMPERAGE (FOR SIGNAL CONTACT)	10P:1.0 A MAX. AC/DC x PIN COUNTS = 10.0 A (TOTAL) 12P AND OVER : 12.0 A AC/DC (TOTAL)
OPERATING TEMPERATURE	233~358K(-40°C~85°C)
OPERATING HUMIDITY	85% MAX.(NON-CONDENDING)
CONTACT RESISTANCE (FOR SIGNAL CONTACT)	INITIAL : 40mohm MAX. / AFTER TEST : Δ 40mohm MAX.
CONTACT RESISTANCE (FOR GROUND)	INITIAL : 20mohm MAX. / AFTER TEST : Δ 20mohm MAX.
INSULATION RESISTANCE	INITIAL : 1,000Mohm MIN. / AFTER TEST : 500Mohm MIN.
DIELECTRIC WITHSTANDING VOLTAGE	AC250V 1min
DURABILITY	10 CYCLES
MATING FORCE (INITIAL / AFTER TEST)	INITIAL 2.0N/Pin MAX.
UNMATING FORCE (INITIAL / AFTER TEST)	10 CYCLES 0.15N/Pin MIN.
COPLANARITY	0.08 MAX
PRODUCT SPECIFICATION	PRS-2607
TEST REPORT	TR-19055
PACKING STANDARD	PST-18022
INSTRUCTION MANUAL	HIM-18019
APPEARANCE CRITERIA No.	QLS-A***

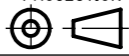
ANGLE	$\pm 2^\circ$	6 OVER 30 MAX.	± 0.3	PROJECTION 	SERIES No. R2	CUSTOMER COPY		
6 MAX.	± 0.2	30 OVER 120 MAX.	± 0.5					
GENERAL TOLERANCE.				TITLE NOVASTACK® 35-HDN PLUG ASSEMBLY	SCALE	I-PEX		
DWG.	DATE							
CHK.								
APP.								
				DWG. No.	20864	SIZE A3	SHEET 4/6	REV. 10

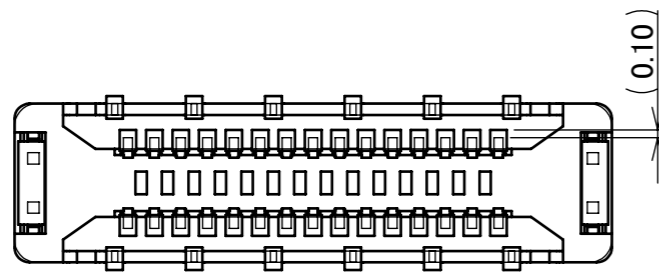

CONNECTOR ON RECOMMENDED FOOTPRINT PATTERN

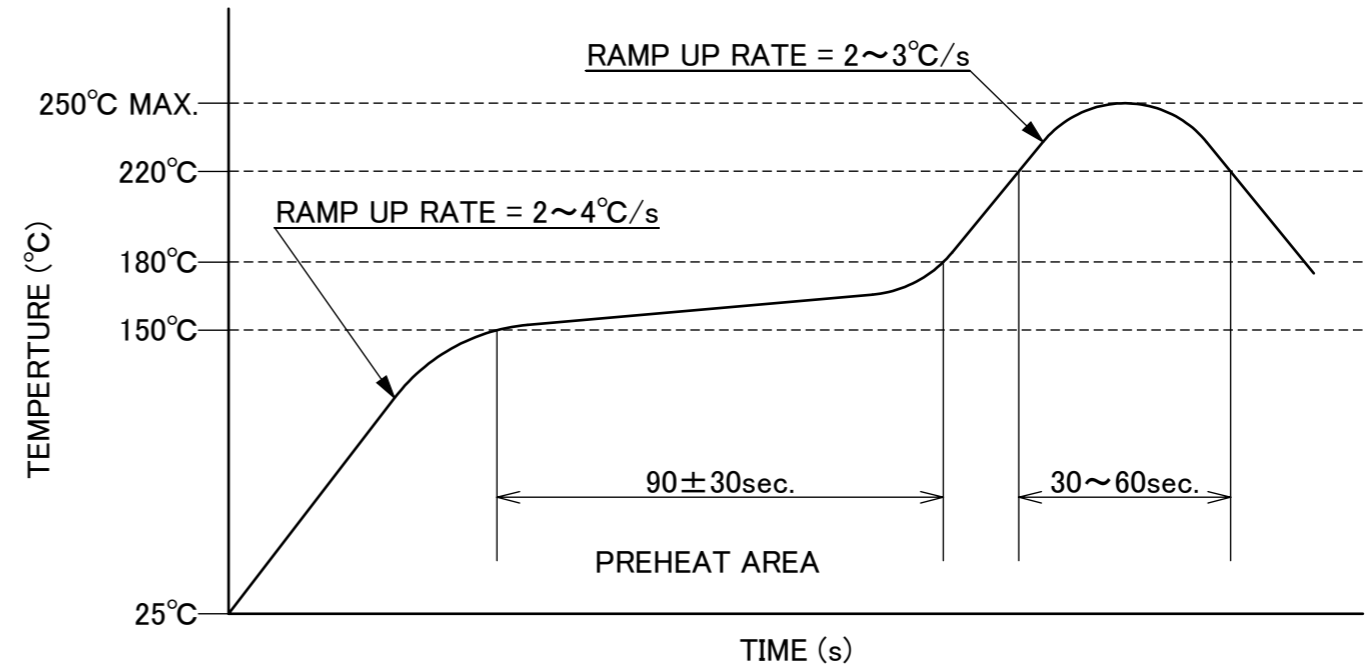

REFLOW TEMPERATURE PROFILE
 SENJU METAL INDUSTRY CO., LTD. : M705-SHF(Sn96.5 Ag3.0 Cu0.5)

ANGLE	±2°	6 OVER 30 MAX.	±0.3	PROJECTION 	SERIES No. R2	CUSTOMER COPY					
6 MAX.	±0.2	30 OVER 120 MAX.	±0.5								
GENERAL TOLERANCE.				TITLE NOVASTACK® 35-HDN PLUG ASSEMBLY	SCALE 10:1	I-PEX					
DWG.	DATE								UNIT mm		
CHK.									SIZE A3	SHEET 5/6	REV. 10
APP.									DWG. No. 20864		

PART NO.	Pos.	A	B	C	QTY. PER EMBOSS REEL (PIECES / REEL)	QTY. PER PACKING CARTON (REELS / CARTON)
20864-010E-01	10	12.0	5.50	4.46	20,000 / REEL	20,000 × 9 REELS = 180,000
20864-020E-01	20	16.0	7.50	6.21		20,000 × 7 REELS = 140,000
20864-030E-01	30	16.0	7.50	8.21		

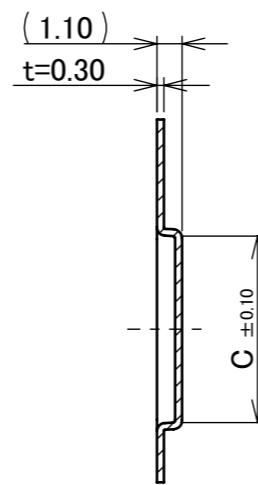
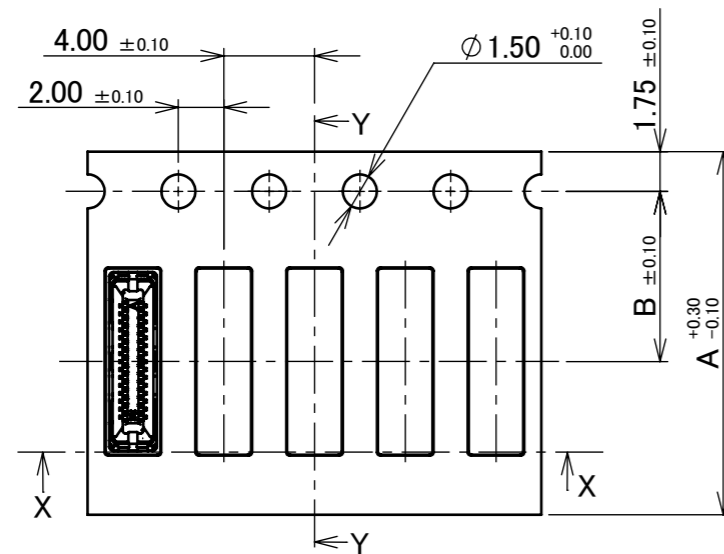
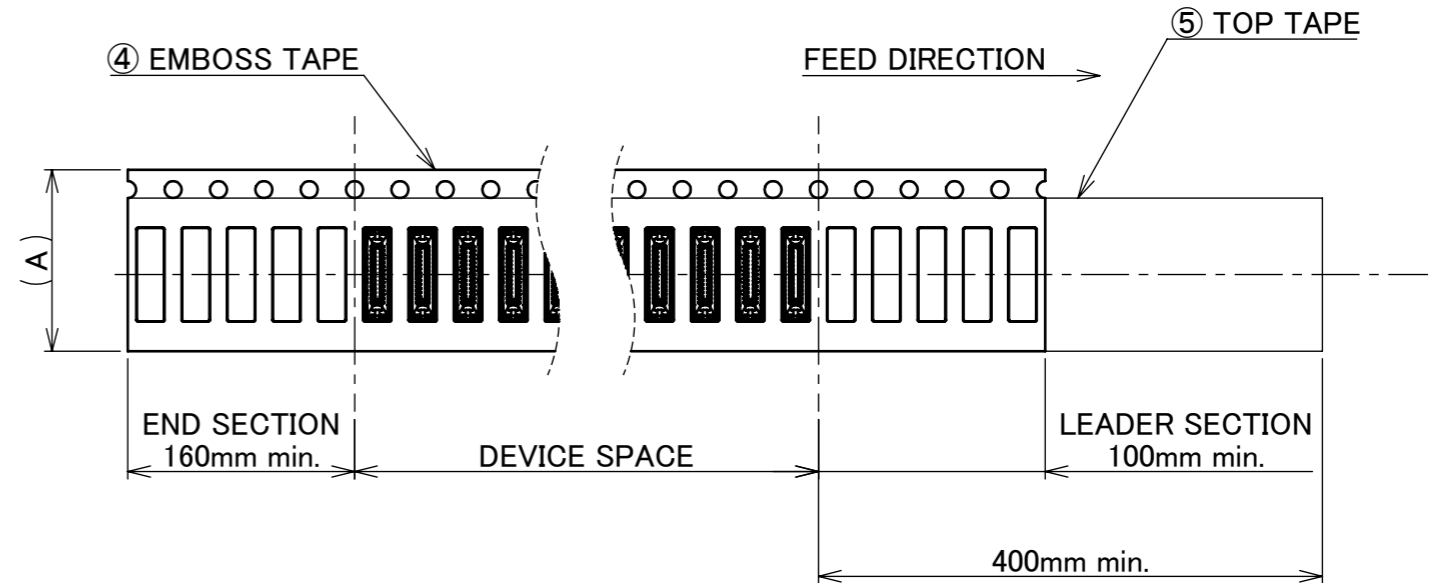
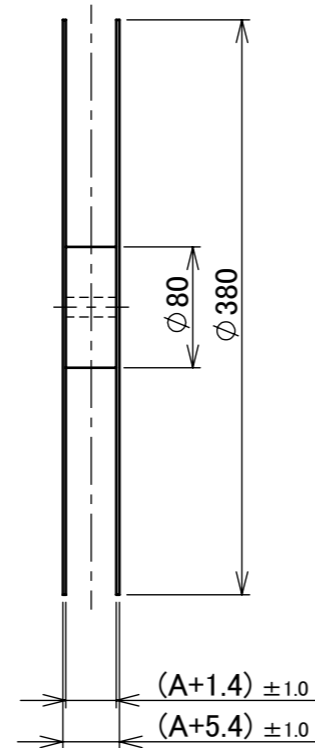
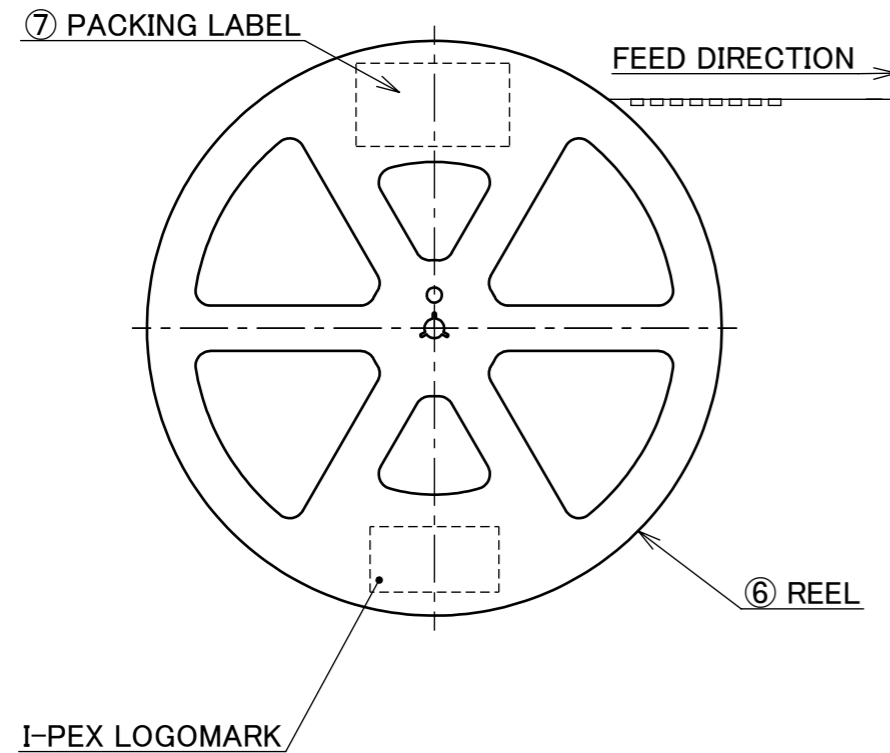

SECT. Y-Y
S = 3 : 1

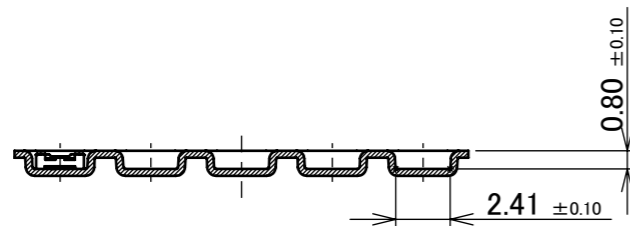

SECT. X-X
S = 3 : 1

NOTES.

- TAPING SPECIFICATION FOLLOWS JIS C 0806 (IEC 60286-3).
- MAKE EMPTY SECTION OF LEADER AND END ON EACH END OF THE TAPE.
- TOP TAPE SHALL NOT STICK OUT FROM EMBOSS TAPE.
- TOP TAPE SHALL NOT COVER FEED HOLE.

NO.	DISCRIPTION	MATERIAL	FINISH , REMARKS
7	PACKING LABEL	-	-
6	REEL	PS	ANTI-STATIC TYPE BLACK
5	TOP TAPE	PET t=0.062 TRANSPARENCY	ANTI-STATIC TYPE
4	EMBOSS TAPE	PS t=0.3 TRANSPARENCY	ANTI-STATIC TYPE

ANGLE	±2°	6 OVER 30 MAX.	±0.3	PROJECTION	SERIES No.	CUSTOMER COPY			
6 MAX.	±0.2	30 OVER 120 MAX.	±0.5		R2				
GENERAL TOLERANCE.				TITLE	NOVASTACK® 35-HDN PLUG ASSEMBLY		SCALE	1:X	
DWG.	DATE					UNIT	mm		
CHK.						SIZE	SHEET	6/6	REV.
APP.				DWG. No.	20864	A3			10