

Recommended P/N 30029-080T-01F

PART NO.	CIRCUIT No./CONTACT LENGTH		BOSS	NOTES
	LONG PIN	MIDDLE PIN		
30029-080T-F	1, 2, 79, 80	OTHERS	WITHOUT BOSS	WITH SCREW
30029-080T-01F				WITHOUT SCREW
30029-080T-02F			WITH BOSS	WITH SCREW
30029-080T-03F				WITHOUT SCREW

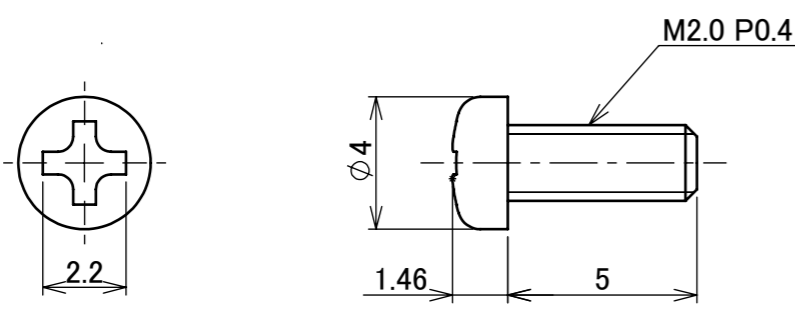

RoHS Compliant

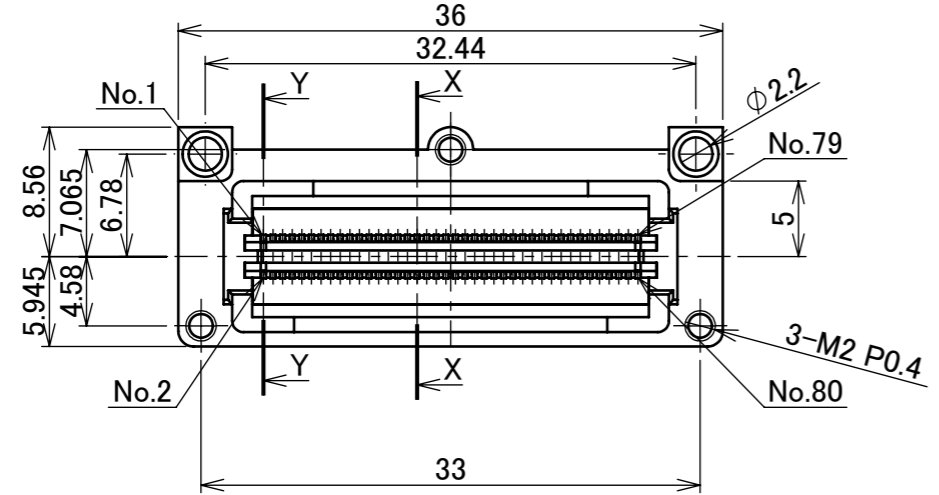
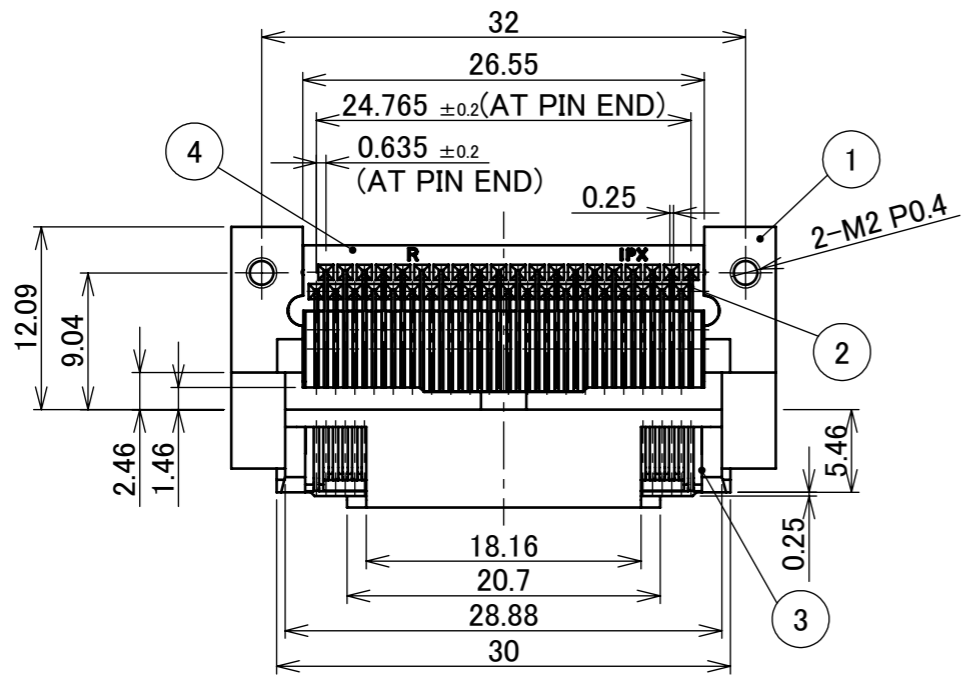

SCREW 90042-001 (S = 5/1)

NOTE
1. CONNECTOR TO BE MATED: 30030

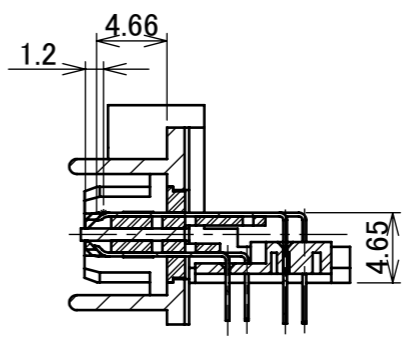
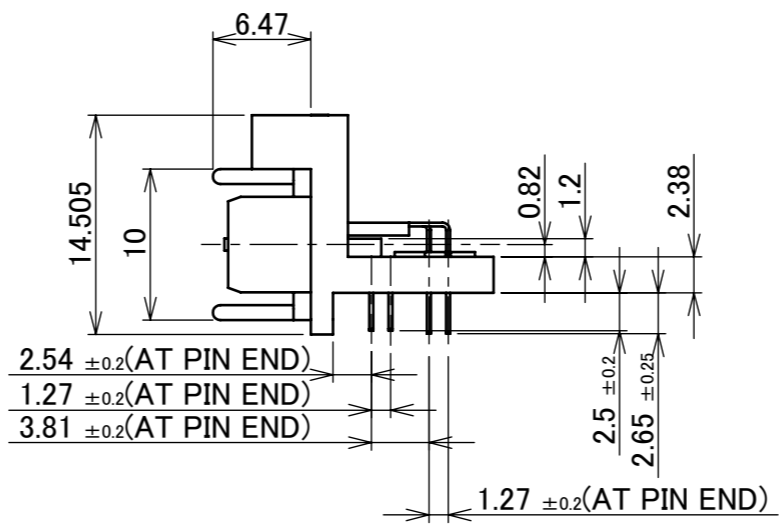
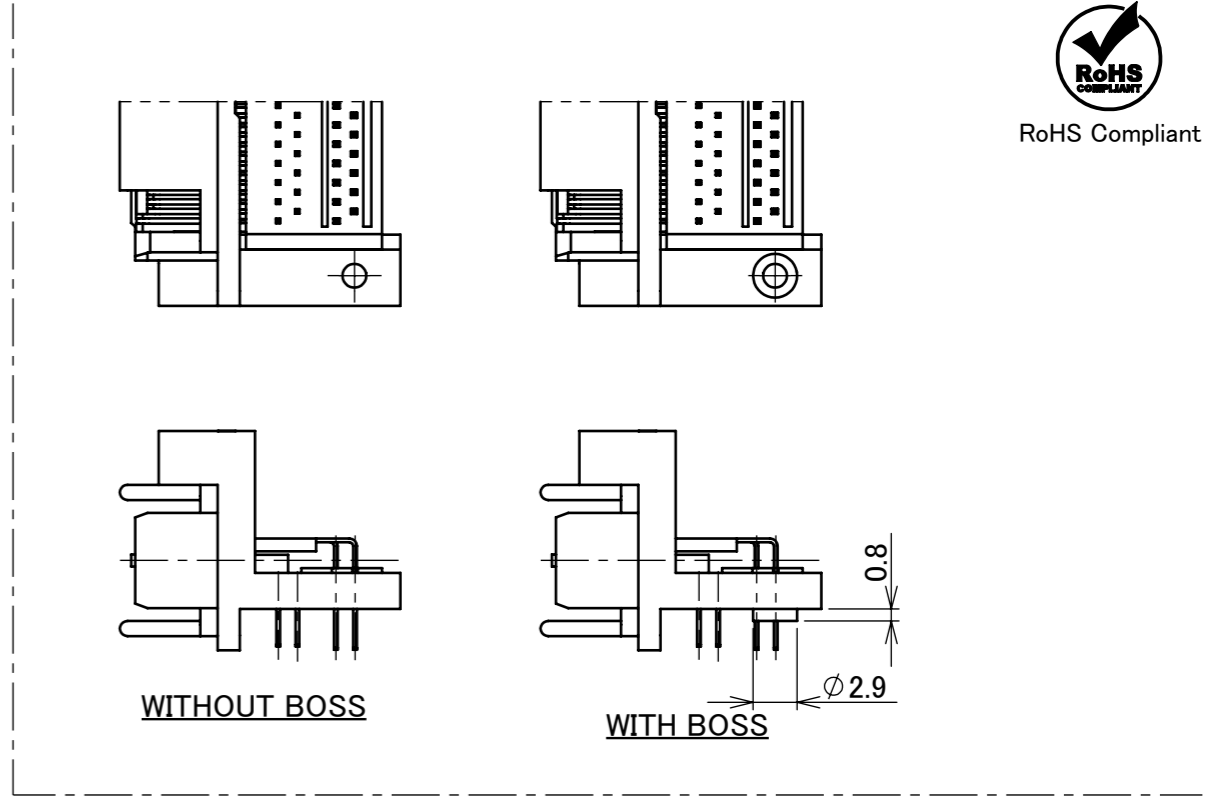

SECT. X-X (MIDDLE PIN)

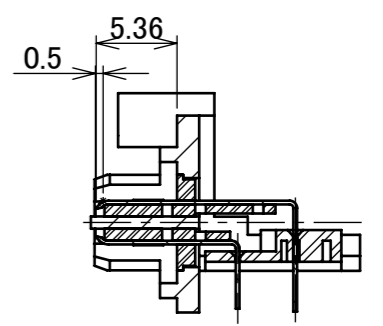

SECT. Y-Y (LONG PIN)

NO.	DISCRIPTION	MATERIAL	FINISH, REMARKS
4	LOCATOR PLATE	PA	BLACK UL94V-0
3	PLUG INSULATOR	PPS	BLACK UL94V-0
2	PLUG CONTACT	COPPER ALLOY	CONTACT PART Au FLASH OVER Pd/Ni SOLDER TAIL Au FLASH
1	PLUG SHELL	Zn ALLOY	Ni PLATING

REV.	ECN	BY	DATE	APP.	APP.	CHG.	DATE	APP.	PROJECTION	SERIES No.	TITLE	SCALE	SHEET	REV.
17	Z240866	Y.I	Jul./02/'24	S.S	ANGLE	±2°	6 OVER 30 MAX.	±0.3	PROJECTION	R9	MINIDOCK™ Slim Type 80P RIGHT ANGLE PLUG	2:1	A3	17
16	Z240688	Y.I	Jun./06/'24	M.T	6 MAX.	±0.2	30 OVER 120 MAX.	±0.5						
15	Z220241	M.H	Mar./18/'22	Y.H	GENERAL TOLERANCE.									
14	Z191328	IMI	Oct./01/'19	Y.S	DWG.	E.Kawabe	DATE	1996/07/04						
13	Z180838	R.H	June/28/'18	TAK	CHK.	S.Ishibashi								
12	Z170908	R.H	Sept./26/'17	M.T	APP.	Y.Fukuda								
REVISION RECORD										DWG. No.	30029	SIZE	1/4	

ITEMS	SPECIFICATION
RATING VOLTAGE	250V AC (PER CONTACT PIN)
RATING AMPERAGE (FOR CONTACT)	0.5A AC/DC (PER CONTACT PIN)
OPERATING TEMPERATURE	208~358K(-65°C~+85°C)
OPERATING HUMIDITY	85% MAX.
CONTACT RESISTANCE (FOR CONTACT)	INITIAL : 70mohm MAX. / AFTER TEST : \triangleleft 25mohm MAX.
INSULATION RESISTANCE	INITIAL : 10,000Mohm MIN. / AFTER TEST : 1,000Mohm MIN.
DIELECTRIC WITHSTANDING VOLTAGE	AC500V 1min
DURABILITY	5,000 CYCLES
MATING FORCE (INITIAL)	0.9N/pos. MAX.
UNMATING FORCE (AFTER TEST)	0.059N/pos. MIN.
COPLANARITY	-
PRODUCT SPECIFICATION	PRS-1011
TEST REPORT	TR-9020
PACKING STANDARD	300-141
INSTRUCTION MANUAL	-
APPEARANCE CRITERIA No.	QLS-A***

ANGLE	$\pm 2^\circ$	6 OVER 30 MAX.	± 0.3	PROJECTION 	SERIES No. R9	CUSTOMER COPY		
6 MAX.	± 0.2	30 OVER 120 MAX.	± 0.5					
GENERAL TOLERANCE.				TITLE MINIDOCK™ Slim Type 80P RIGHT ANGLE PLUG	SCALE	I-PEX		
DWG.	DATE							
CHK.								
APP.								
				DWG. No.	30029	SIZE A3	SHEET 2/4	REV. 17

PART NO.	A
30029-080T-F	2.3
30029-080T-01F	
30029-080T-02F	3.1
30029-080T-03F	

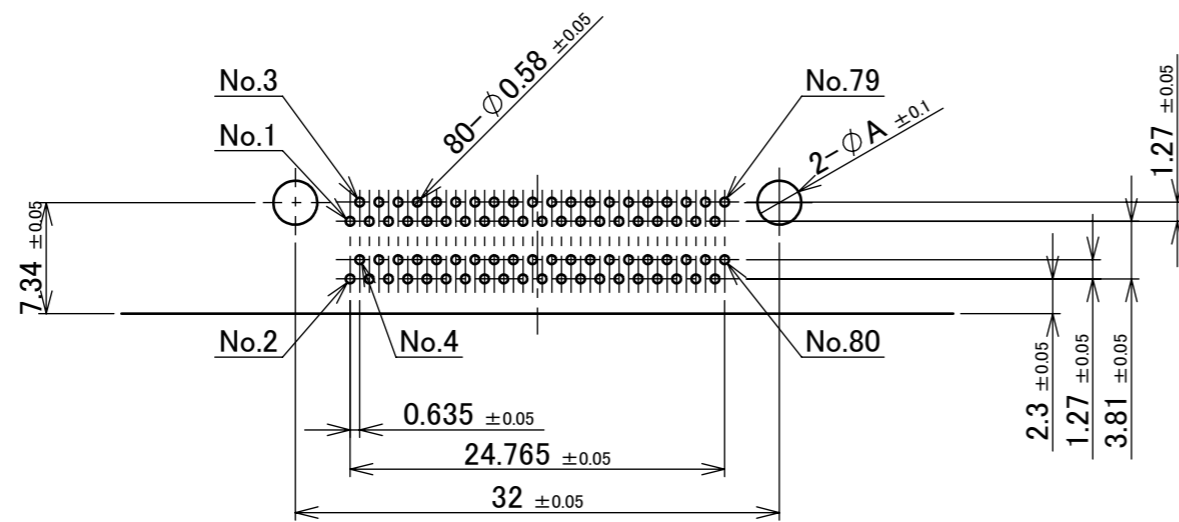

RECOMMENDED FOOTPRINT PATTERN t=1.6

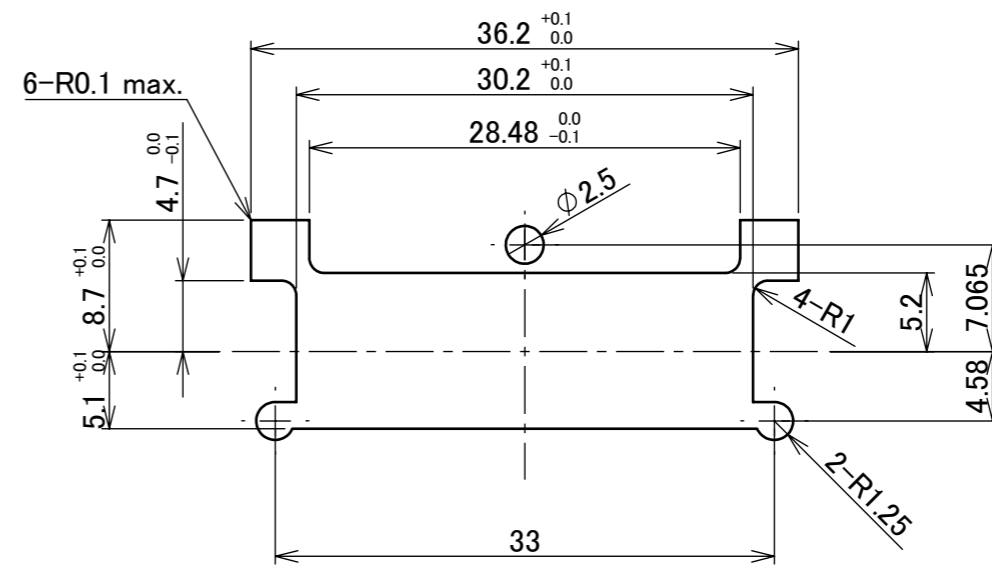

RECOMMENDED PANEL

ANGLE	±2°	6 OVER 30 MAX.	±0.3	PROJECTION ⊕	SERIES No. R9	CUSTOMER COPY		
6 MAX.	±0.2	30 OVER 120 MAX.	±0.5			SCALE 2:1	I-PEX	
GENERAL TOLERANCE.				TITLE MINIDOCK™ Slim Type 80P RIGHT ANGLE PLUG		UNIT mm		
DWG.	DATE			DWG. No. 30029		SIZE A3		
CHK.								
APP.								

PART NO.	Pos.	QTY./ TRAY	QTY./ SHIPPING CARTON	QTY./ PACKING CARTON
30029-080T-F	80P	24	24 × 3 = 72	72 × 4 = 288
30029-080T-01F				

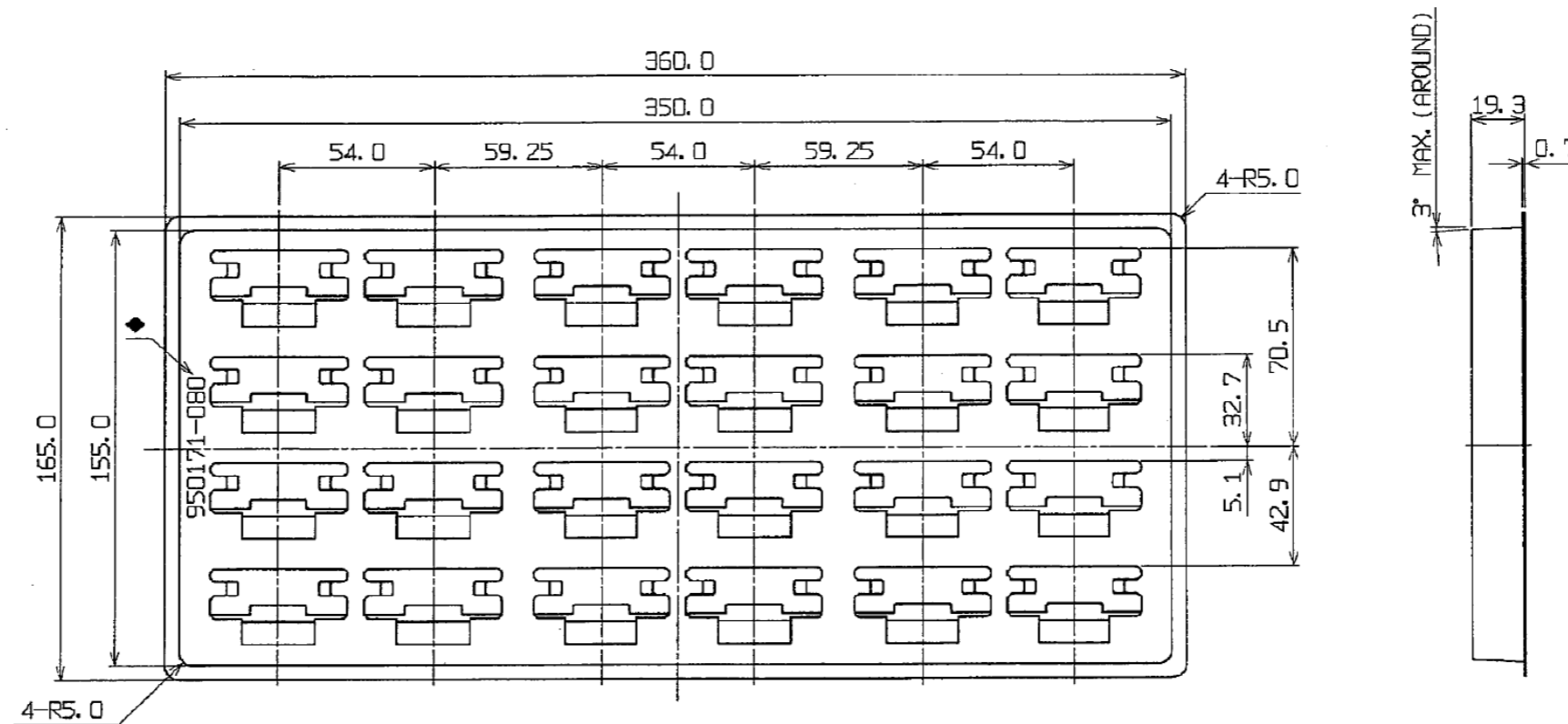

5	TRAY	PET	-
NO.	DISCRIPTION	MATERIAL	FINISH , REMARKS
ANGLE	±2°	6 OVER 30 MAX.	±0.3
6 MAX.	±0.2	30 OVER 120 MAX.	±0.5
GENERAL TOLERANCE.			
DWG.	DATE	TITLE	SCALE
CHK.		MINIDOCK™ Slim Type	1:X
APP.		80P RIGHT ANGLE PLUG	UNIT
			mm
		DWG. No.	SIZE SHEET REV.
		30029	A3 4/4 17