

PART NO.
30007-200T-03F

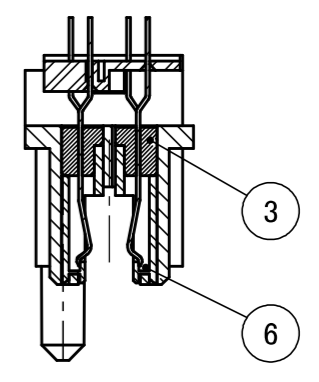

RoHS Compliant

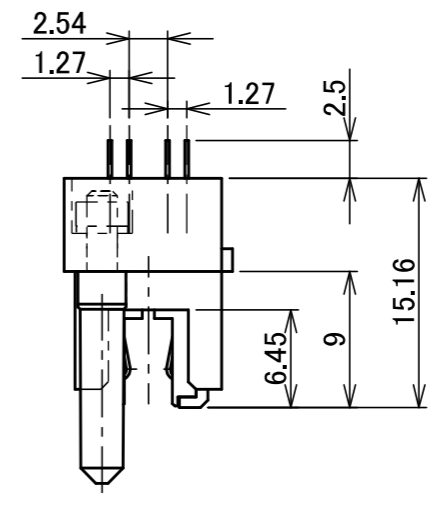
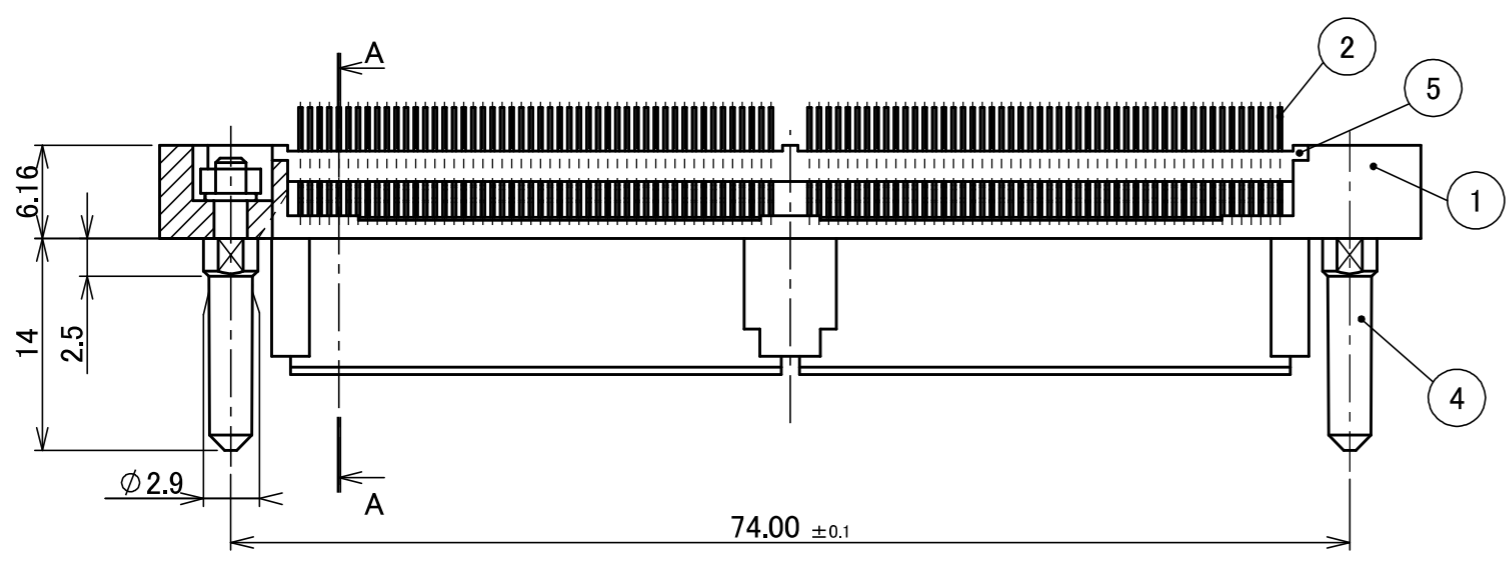

SECT. A-A

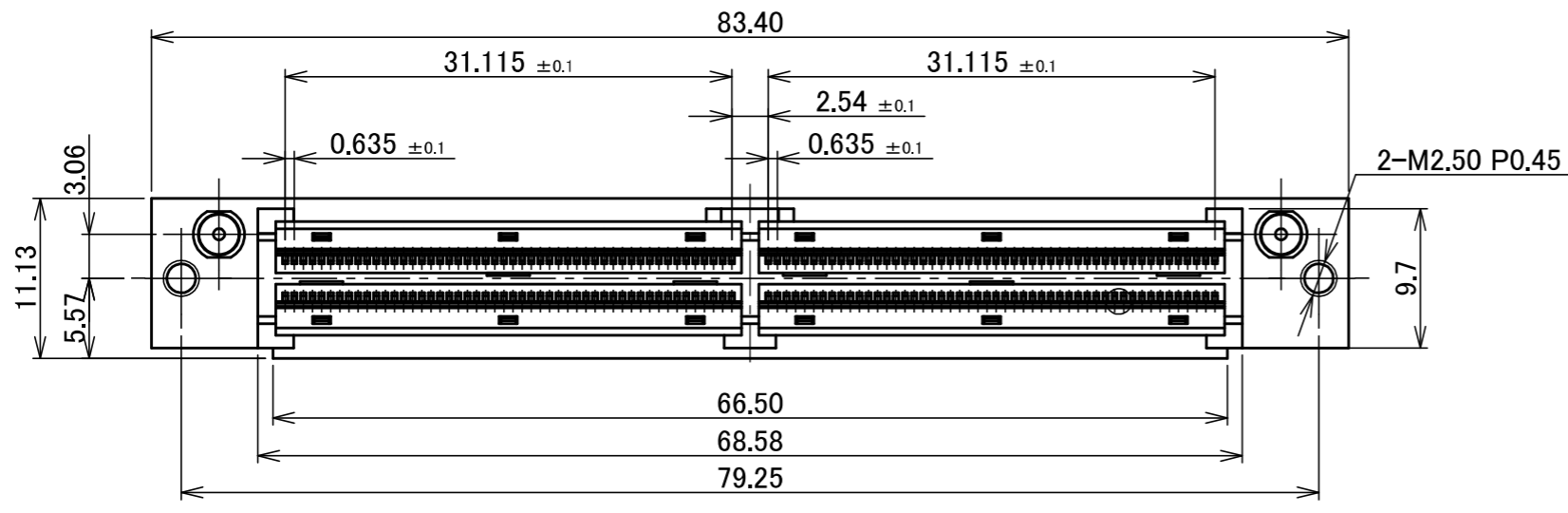

6	CONTACT GUIDE	PPS	BLACK UL94V-0
5	LOCATOR PLATE	PA	BLACK UL94V-0
4	GUIDE PIN	STEEL	Ni PLATING
3	RECE INSULATOR	PPS	BLACK UL94V-0
2	RECE CONTACT	COPPER ALLOY	CONTACT PART Au FLASH OVER Pd-Ni SOLDER TAIL Au FLASH
1	RECE SHELL	Zn ALLOY	Ni OVER Cu PLATING
NO.	DISCRIPTION	MATERIAL	FINISH , REMARKS

NOTE
1. CONNECTOR TO BE MATED: 30094

18	Z241576	R.TA	Nov./27/'24	S.S	ANGLE	±2°	6 OVER 30 MAX.	±0.3	PROJECTION ⊕	SERIES No. R15	CUSTOMER COPY			
17	Z240897	K.W	July/09/'24	S.S	6 MAX.	±0.2	30 OVER 120 MAX.	±0.5						
16	Z240688	Y.I	Jun./06/'24	M.T	GENERAL TOLERANCE.				TITLE MINIDOCK™ Standard Type CONNECTOR VERTICAL RECEPTACLE	SCALE 2:1	UNIT mm	SHEET 1/4	REV. 18	
15	Z220241	M.H	Mar./18/'22	Y.H	DWG.	E.Kawabe		DATE						1994/11/11
14	Z191328	IMI	Oct./01/'19	Y.S	CHK.	T.Harada								
13	Z180838	R.H	June/28/'18	TAK	APP.	K.Katabuchi								
REV.	ECN	BY	DATE	APP.	REVISION RECORD				DWG. No.	30007	SIZE	A3		

ITEMS	SPECIFICATION
RATING VOLTAGE	250V AC (PER CONTACT PIN)
RATING AMPERAGE (FOR CONTACT)	0.5A AC/DC (PER CONTACT PIN)
OPERATING TEMPERATURE	208~358K(-65°C~+85°C)
OPERATING HUMIDITY	85% MAX.
CONTACT RESISTANCE (FOR CONTACT)	INITIAL : 70mohm MAX. / AFTER TEST : \triangle 25mohm MAX.
INSULATION RESISTANCE	INITIAL : 10,000Mohm MIN. / AFTER TEST : 1,000Mohm MIN.
DIELECTRIC WITHSTANDING VOLTAGE	AC500V 1min
DURABILITY	5,000 CYCLES
MATING FORCE (INITIAL)	0.9N/pos. MAX.
UNMATING FORCE (AFTER TEST)	0.059N/pos. MIN.
COPLANARITY	-
PRODUCT SPECIFICATION	PRS-1011
TEST REPORT	TR-9020
PACKING STANDARD	300-030
INSTRUCTION MANUAL	-
APPEARANCE CRITERIA No.	QLS-A***

ANGLE	$\pm 2^\circ$	6 OVER 30 MAX.	± 0.3	PROJECTION 	SERIES No. R15	CUSTOMER COPY		
6 MAX.	± 0.2	30 OVER 120 MAX.	± 0.5					
GENERAL TOLERANCE.				TITLE MINIDOCK™ Standard Type CONNECTOR VERTICAL RECEPTACLE	SCALE 	UNIT mm		
DWG.	DATE							
CHK.								
APP.								
				DWG. No.	30007	SIZE A3	SHEET 2/4	REV. 18

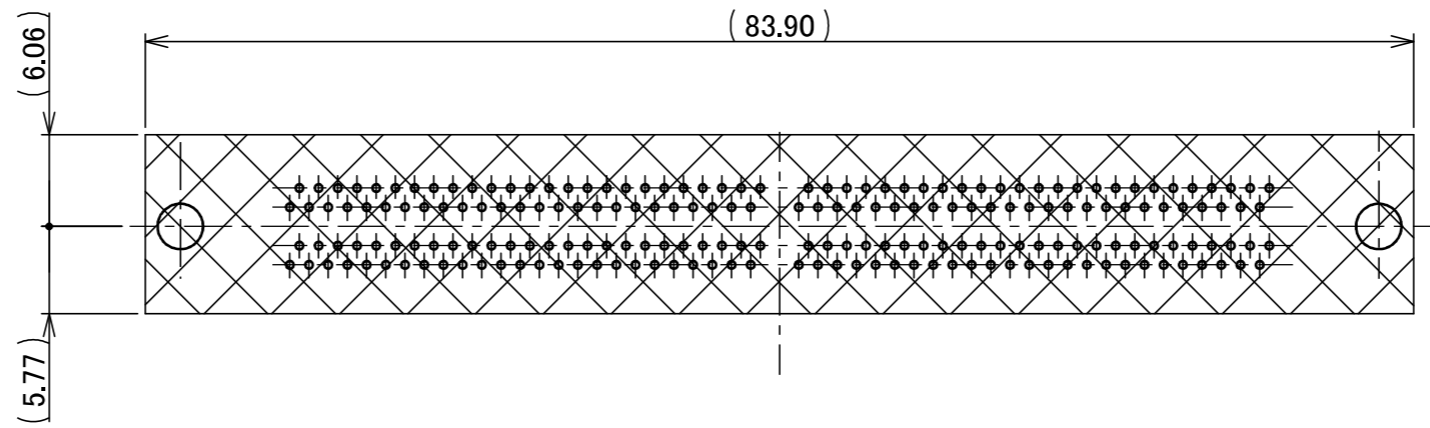
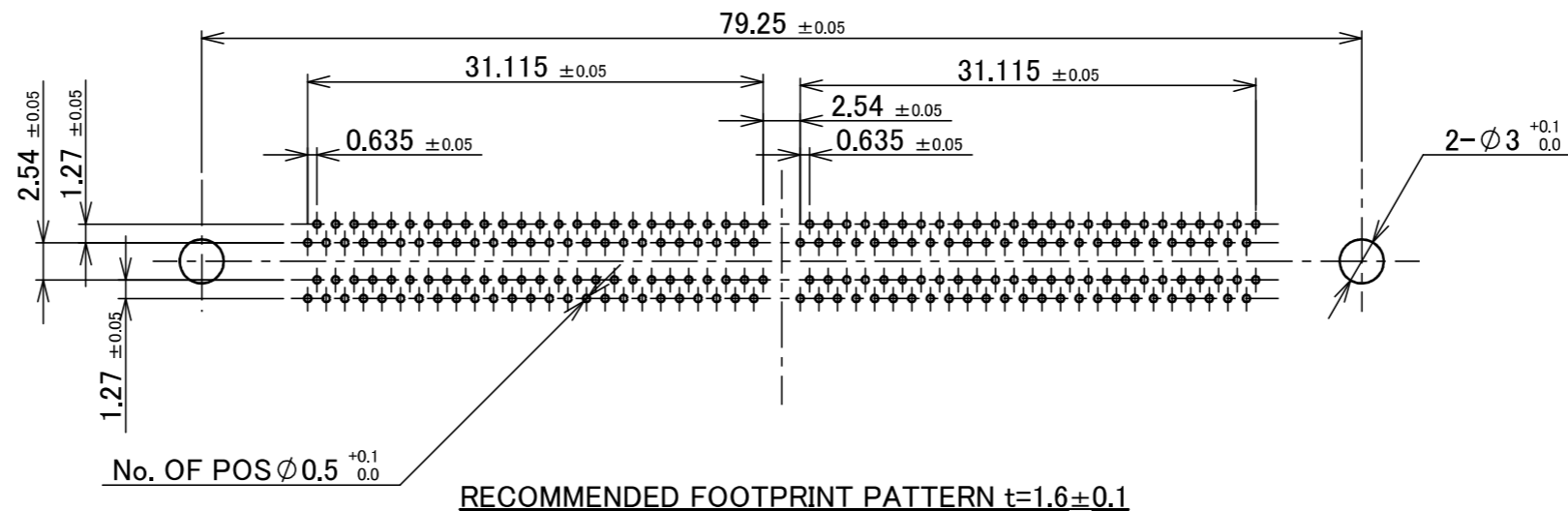

ANGLE	±2°	6 OVER 30 MAX.	±0.3	PROJECTION ⊕	SERIES No. R15	CUSTOMER COPY		
6 MAX.	±0.2	30 OVER 120 MAX.	±0.5					
GENERAL TOLERANCE.				TITLE MINIDOCK™ Standard Type CONNECTOR VERTICAL RECEPTACLE	SCALE 2:1 UNIT mm	I-PEX		
DWG.	DATE							
CHK.								
APP.								
				DWG. No.	30007	SIZE A3	SHEET 3/4	REV. 18

PART NO.	Pos.	QTY./ TRAY	QTY./ SHIPPING CARTON	QTY./ PACKING CARTON
30007-200T-03F	200P	15	15 × 5 = 75	75 × 4 = 300

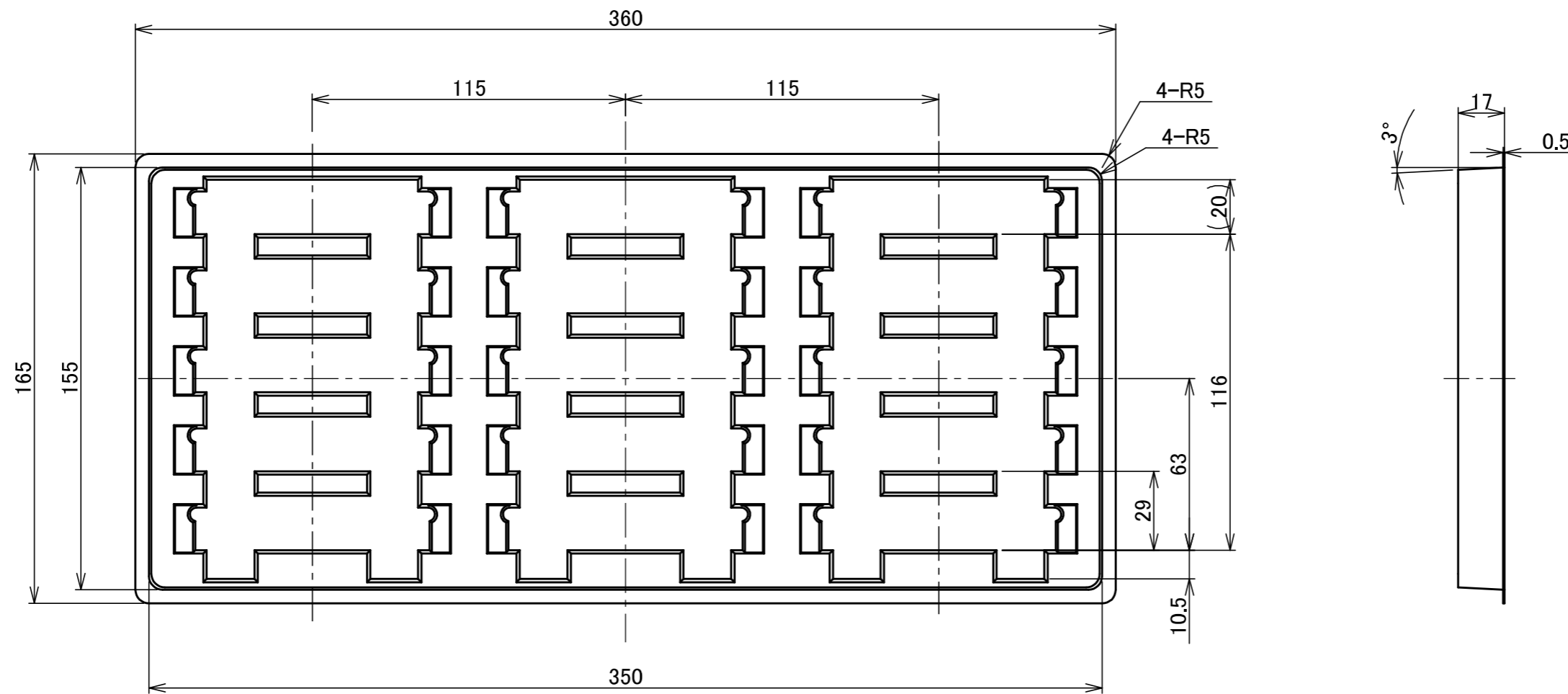

7	TRAY	PVC	-
NO.	DISCRIPTION	MATERIAL	FINISH , REMARKS

ANGLE	±2°	6 OVER 30 MAX.	±0.3	PROJECTION ⊕	SERIES No. R15	CUSTOMER COPY
	6 MAX.	±0.2	30 OVER 120 MAX.			
GENERAL TOLERANCE.				TITLE		SCALE
DWG.	DATE			MINIDOCK™ Standard Type CONNECTOR VERTICAL RECEPTACLE		1:X
CHK.						UNIT
APP.				DWG. No.		mm
				30007		SIZE
						A3
						SHEET
						4/4
						REV.
						18

Confidential C

I-PEX Inc.

QKE-DFE06-02 REV.12