

Recommended P/N 30094-200T-01F

PART No.	SCREW
30094-200T-F	WITH SCREW
30094-200T-01F	WITHOUT SCREW

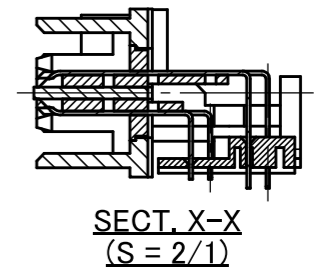

RoHS Compliant

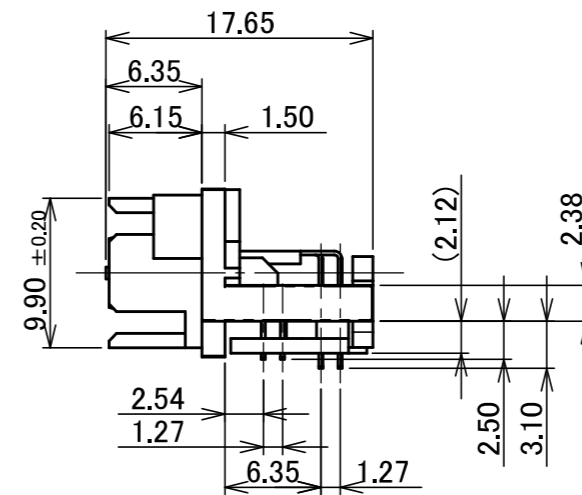
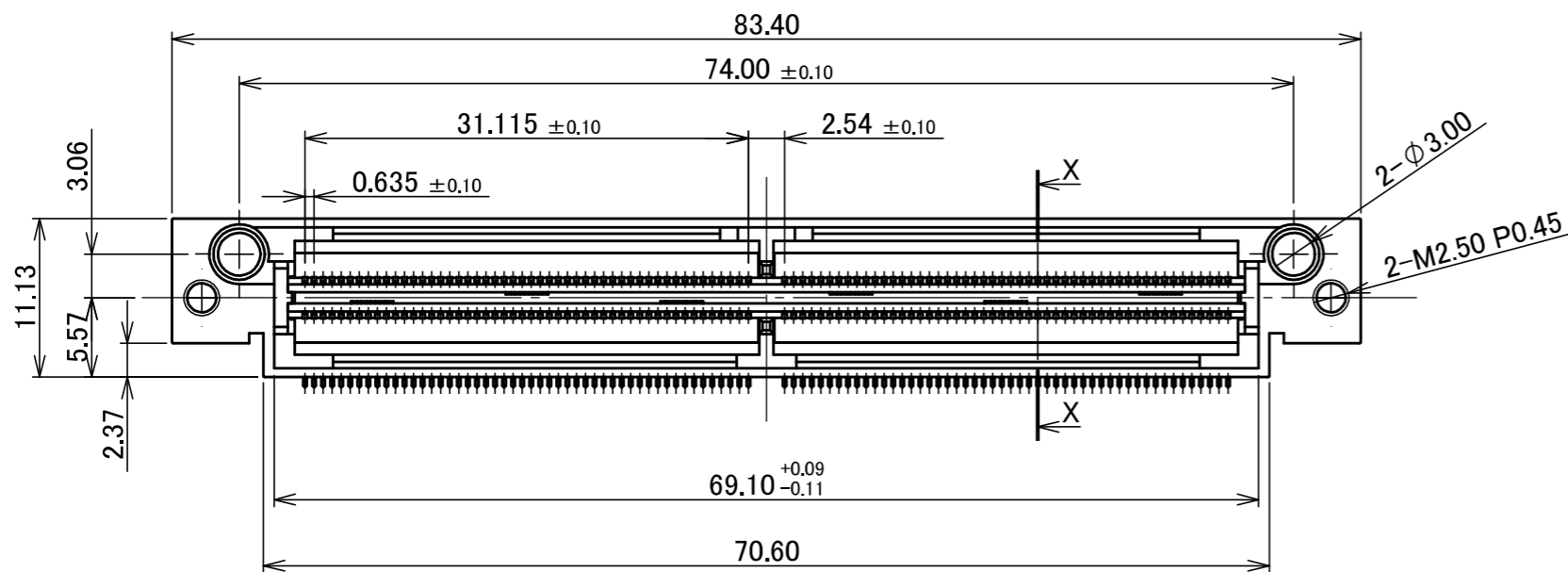
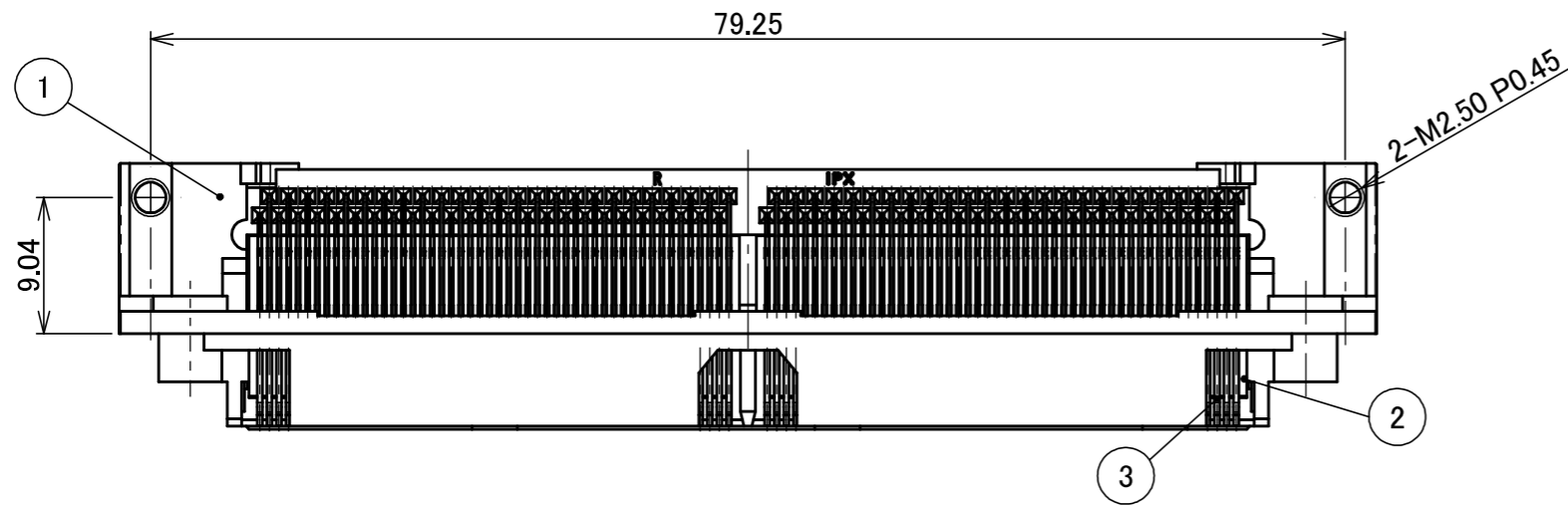

3	CONTACT	COPPER ALLOY	CONTACT AREA : Au FLASH SOLDER AREA : Au FLASH
2	INSULATOR	HEAT RESISTING PLASTICS	BLACK, UL94V-0
1	SHELL	Zn ALLOY	-
NO.	DISCRIPTION	MATERIAL	FINISH , REMARKS

NOTES  
1. CONNECTOR TO BE MATED: 30007-200T-03\*

8	Z241576	R.TA	Nov./27/'24	S.S	ANGLE	±2°	6 OVER 30 MAX.	±0.3	PROJECTION ⊕	SERIES No. R0	CUSTOMER COPY	
7	Z240688	Y.I	Jun./06/'24	M.T	6 MAX.	±0.2	30 OVER 120 MAX.	±0.5				
6	Z220241	M.H	Mar./18/'22	Y.H	GENERAL TOLERANCE.				TITLE MINIDOCK™ Standard Type PLUG ALL LONG PIN OFFSET TYPE	SCALE 2:1	UNIT mm	I-PEX
5	Z191320	IMI	Sept./30/'19	Y.S	DWG.	DATE		2005/10/24				
4	Z181197	R.H	Sept./13/'18	TAK	J.Ohsaka		CHK.					
3	Z180101	R.H	Jan./26/'18	M.T	APP.		E.Kawabe					
REV.	ECN	BY	DATE	APP.	APP.	DWG. No.		30094	SIZE	SHEET	REV.	
REVISION RECORD					E.Kawabe		30094		A3	1/4	8	

ITEMS	SPECIFICATION
RATING VOLTAGE	250V AC (PER CONTACT PIN)
RATING AMPERAGE (FOR CONTACT)	0.5A AC/DC (PER CONTACT PIN)
OPERATING TEMPERATURE	208~358K(-65°C~+85°C)
OPERATING HUMIDITY	85% MAX.
CONTACT RESISTANCE (FOR CONTACT)	INITIAL : 70mohm MAX. / AFTER TEST : $\triangle$ 25mohm MAX.
INSULATION RESISTANCE	INITIAL : 10,000Mohm MIN. / AFTER TEST : 1,000Mohm MIN.
DIELECTRIC WITHSTANDING VOLTAGE	AC500V 1min
DURABILITY	5,000 CYCLES
MATING FORCE (INITIAL)	0.9N/pos. MAX.
UNMATING FORCE (AFTER TEST)	0.059N/pos. MIN.
COPLANARITY	-
PRODUCT SPECIFICATION	PRS-1011
TEST REPORT	TR-9020
PACKING STANDARD	300-251
INSTRUCTION MANUAL	-
APPEARANCE CRITERIA No.	QLS-A***

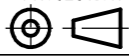
ANGLE	$\pm 2^\circ$	6 OVER 30 MAX.	$\pm 0.3$	PROJECTION 	SERIES No. R0	CUSTOMER COPY		
6 MAX.	$\pm 0.2$	30 OVER 120 MAX.	$\pm 0.5$					
GENERAL TOLERANCE.				TITLE MINIDOCK™ Standard Type PLUG ALL LONG PIN OFFSET TYPE	SCALE	<b>I-PEX</b>		
DWG.	DATE							
CHK.								
APP.								
				DWG. No.	30094	SIZE A3	SHEET 2/4	REV. 8

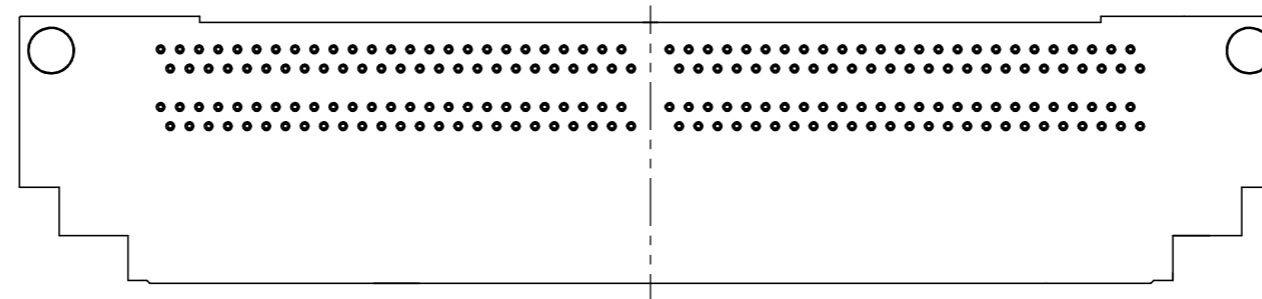
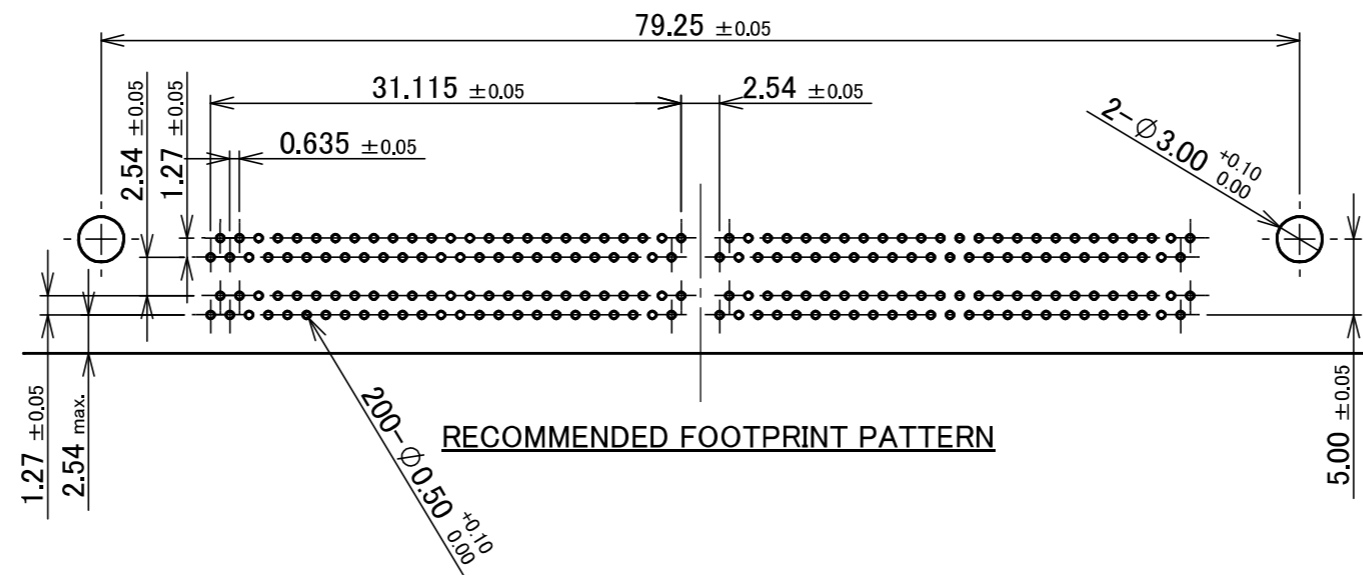

CONNECTOR ON RECOMMENDED FOOTPRINT PATTERN

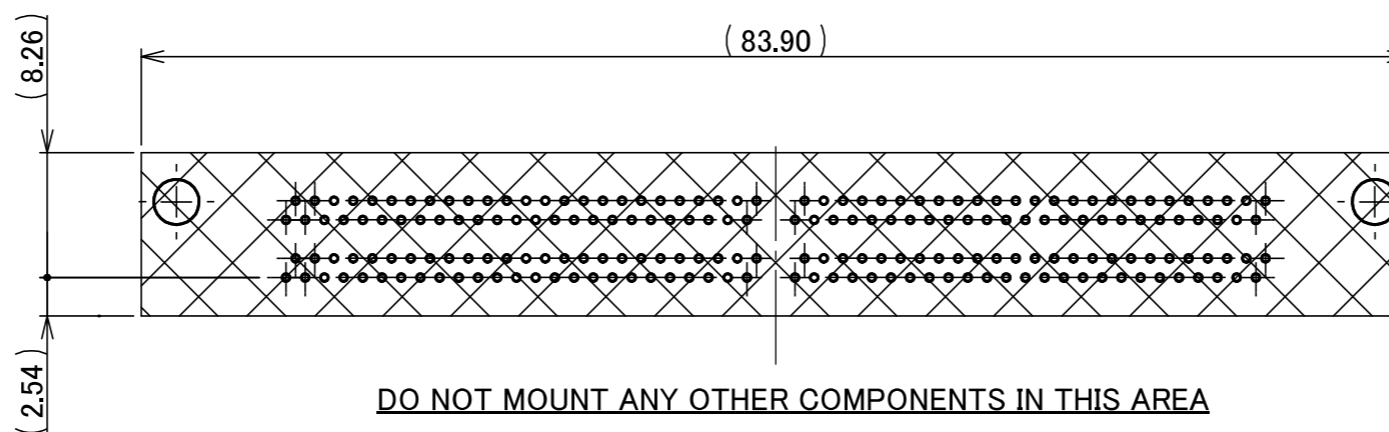

DO NOT MOUNT ANY OTHER COMPONENTS IN THIS AREA

ANGLE	±2°	6 OVER 30 MAX.	±0.3	PROJECTION	SERIES No.	CUSTOMER COPY	
	6 MAX.	±0.2	30 OVER 120 MAX.	±0.5	R0		
GENERAL TOLERANCE.				TITLE	SCALE	I-PEX	
DWG.	DATE			MINIDOCK™ Standard Type PLUG ALL LONG PIN OFFSET TYPE	2:1		
CHK.					UNIT		
APP.				DWG. No.	mm	SIZE	SHEET
				30094	A3	3/4	REV.
						8	

PART NO.	Pos.	QTY./ TRAY	QTY./ SHIPPING CARTON	QTY./ PACKING CARTON
30094-200T-F	200P	21	21 × 4 = 84	84 × 4 = 336
30094-200T-01F				

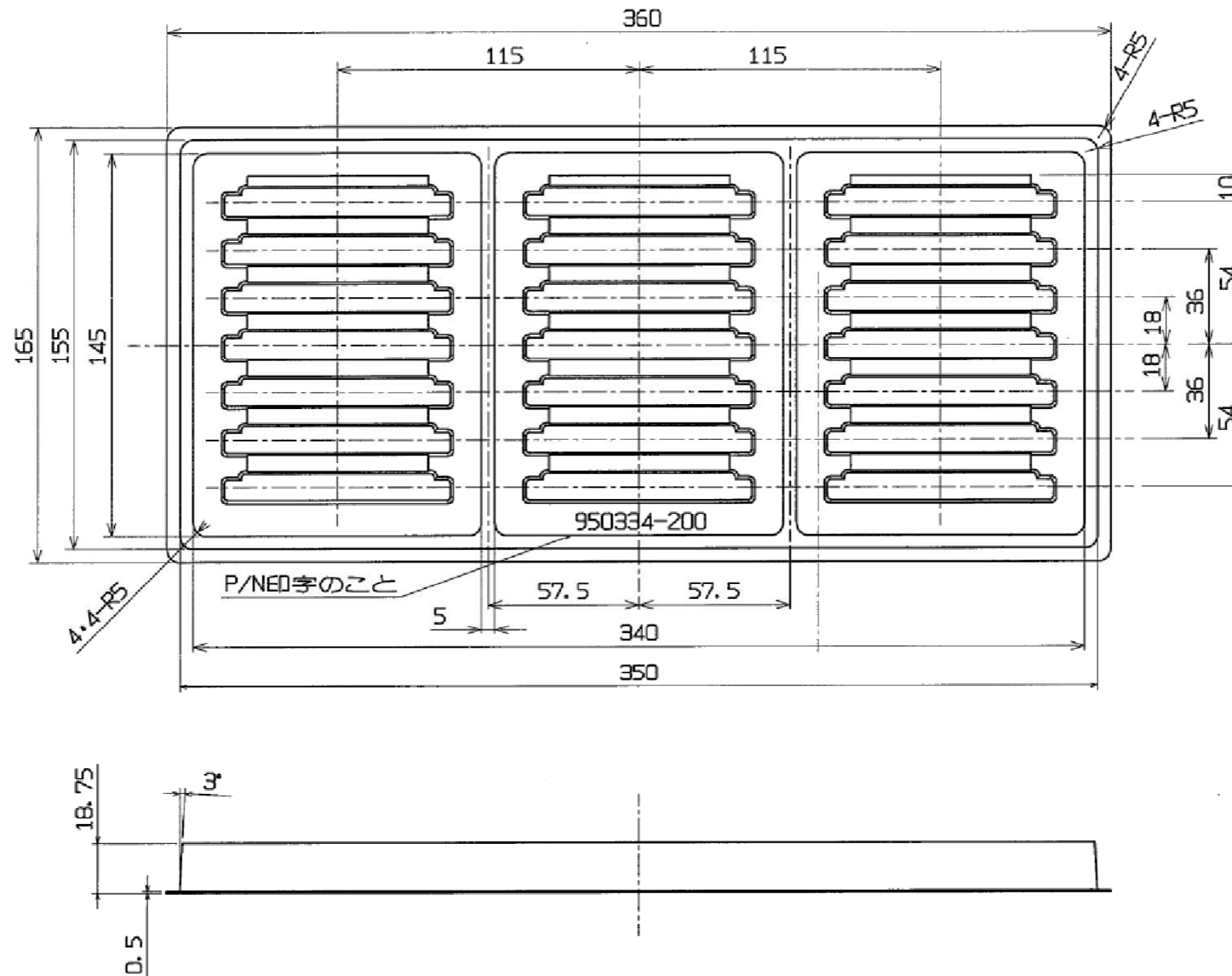

4	TRAY	PS	-																																		
NO.	DISCRIPTION	MATERIAL	FINISH , REMARKS																																		
<table border="1"> <tr> <td>ANGLE</td> <td>±2°</td> <td>6 OVER 30 MAX.</td> <td>±0.3</td> <td rowspan="2">PROJECTION ① ▽</td> <td rowspan="2">SERIES No. R0</td> <td rowspan="2">CUSTOMER COPY</td> </tr> <tr> <td>6 MAX.</td> <td>±0.2</td> <td>30 OVER 120 MAX.</td> <td>±0.5</td> </tr> <tr> <td colspan="4">GENERAL TOLERANCE.</td> <td rowspan="4">TITLE MINIDOCK™ Standard Type PLUG ALL LONG PIN OFFSET TYPE</td> <td rowspan="4">SCALE 1:X</td> <td rowspan="4">UNIT mm</td> </tr> <tr> <td>DWG.</td> <td colspan="2">DATE</td> <td rowspan="3">DWG. No. 30094</td> </tr> <tr> <td>CHK.</td> <td colspan="2"></td> </tr> <tr> <td>APP.</td> <td colspan="2"></td> </tr> <tr> <td>SIZE</td> <td>A3</td> <td>SHEET</td> <td>4/4</td> <td>REV.</td> <td>8</td> </tr> </table>				ANGLE	±2°	6 OVER 30 MAX.	±0.3	PROJECTION ① ▽	SERIES No. R0	CUSTOMER COPY	6 MAX.	±0.2	30 OVER 120 MAX.	±0.5	GENERAL TOLERANCE.				TITLE MINIDOCK™ Standard Type PLUG ALL LONG PIN OFFSET TYPE	SCALE 1:X	UNIT mm	DWG.	DATE		DWG. No. 30094	CHK.			APP.			SIZE	A3	SHEET	4/4	REV.	8
ANGLE	±2°	6 OVER 30 MAX.	±0.3	PROJECTION ① ▽	SERIES No. R0	CUSTOMER COPY																															
6 MAX.	±0.2	30 OVER 120 MAX.	±0.5																																		
GENERAL TOLERANCE.				TITLE MINIDOCK™ Standard Type PLUG ALL LONG PIN OFFSET TYPE	SCALE 1:X	UNIT mm																															
DWG.	DATE		DWG. No. 30094																																		
CHK.																																					
APP.																																					
SIZE	A3	SHEET	4/4	REV.	8																																