

PART NO.  
30001-\*\*-0T-\*\*-F

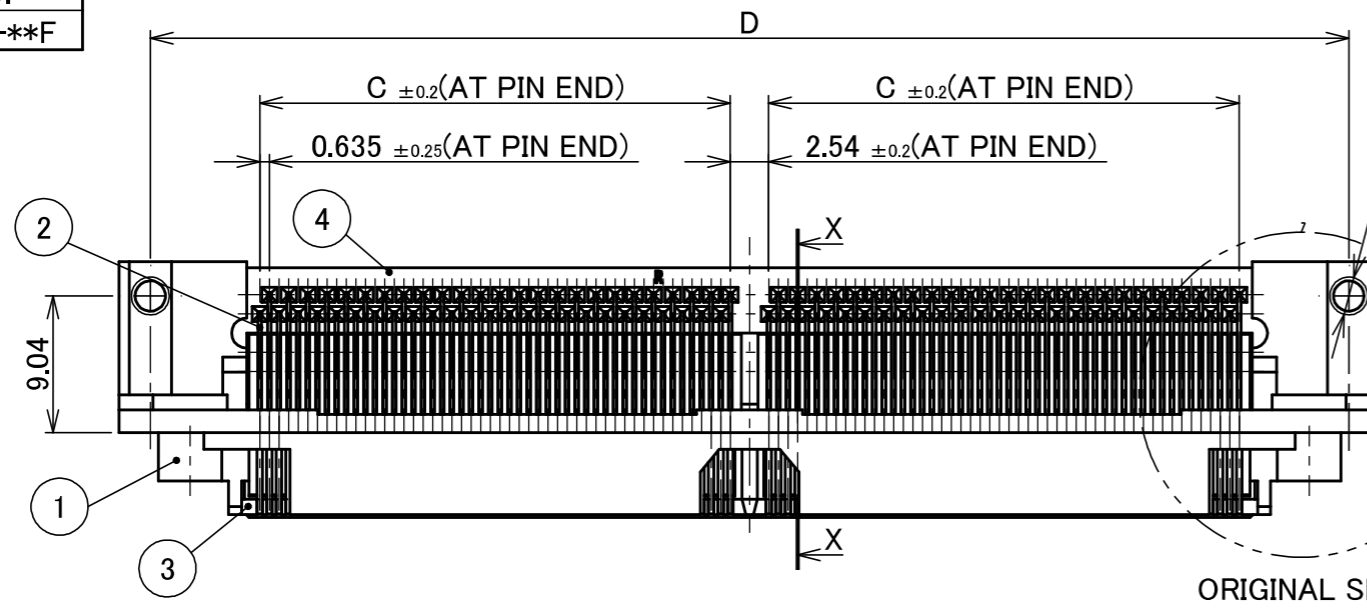

RoHS Compliant



2-M2.5 P0.45  
(SEE P/N90023-001)

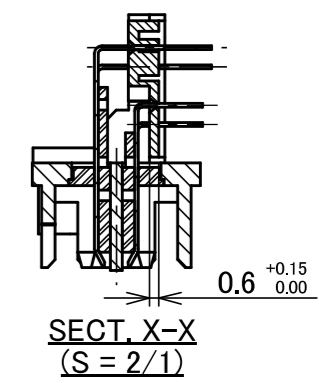
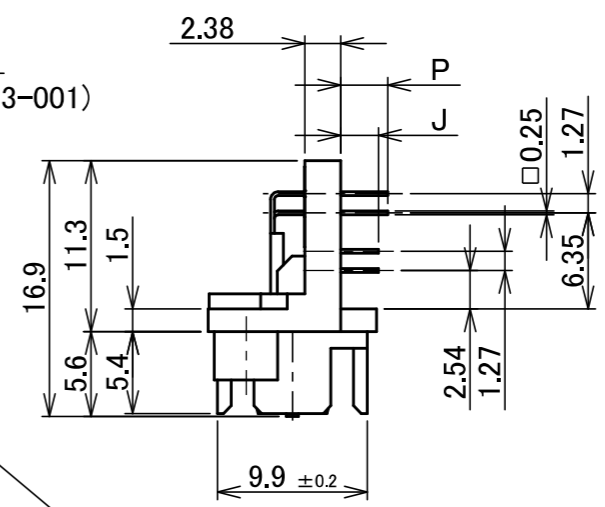

ORIGINAL SHAPE

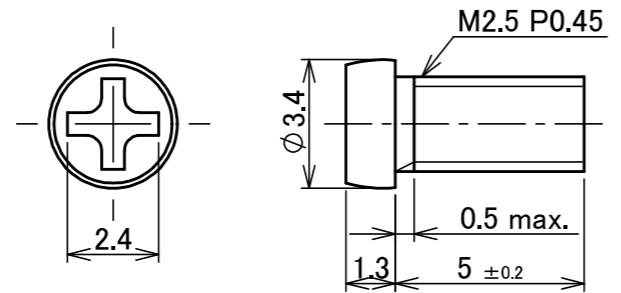
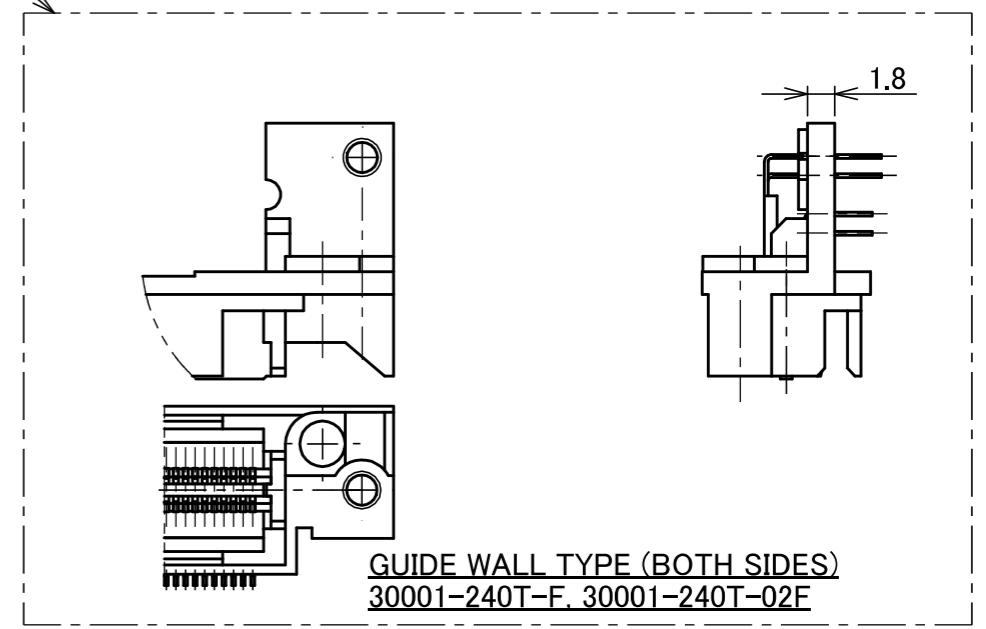
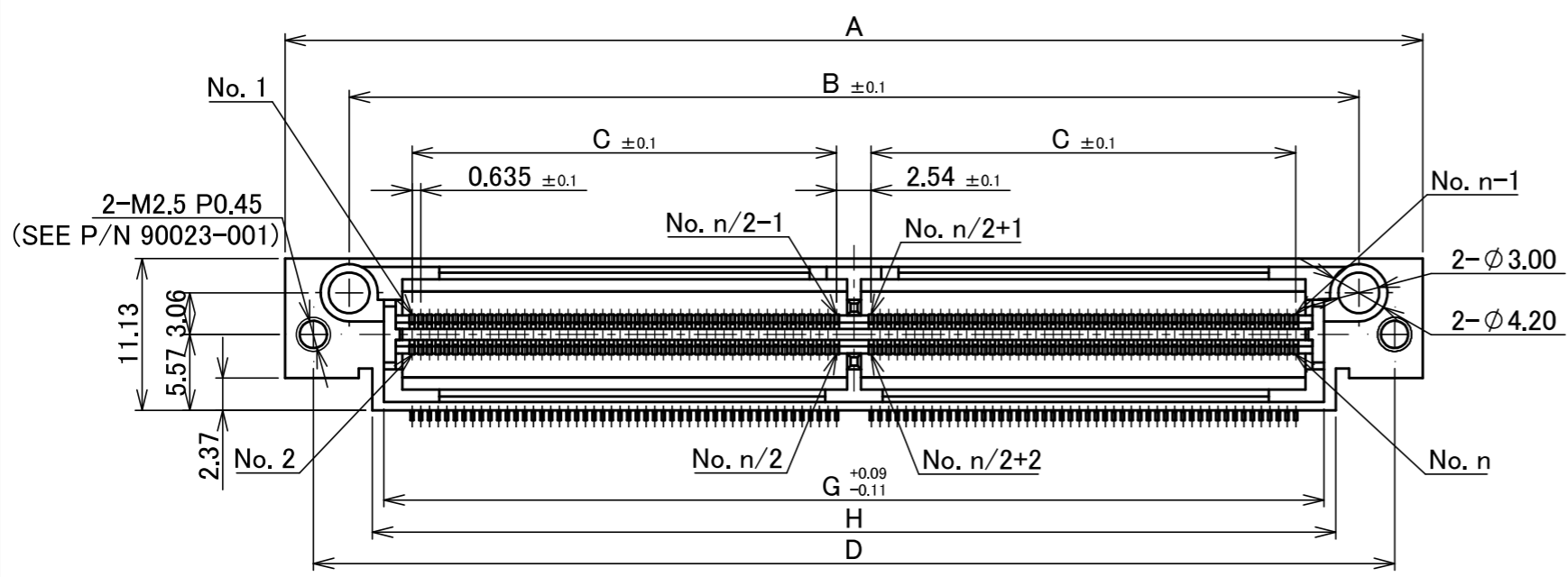



SCREW 90023-001  
(S= 5:1)

30001-\*\*-0T-\*\*-F  
NONE: WITHOUT SCREW  
01, 02: WITH SCREW  
EXAMPLE  
POS.10 : 100P  
24 : 240P

NOTES  
1. CONNECTOR TO BE MATED: 30002, 30007

4	LOCATOR PLATE	PA	BLACK UL94V-0			
3	PLUG INSULATOR	PPS	BLACK UL94V-0			
2	PLUG CONTACT	COPPER ALLOY	ALL OVER Ni 1.27 μm MIN. CONTACT PART Au 0.05 μm MIN.			
1	PLUG SHELL	Zn ALLOY	Ni PLATING			
NO.	DISCRIPTION	MATERIAL	FINISH , REMARKS			
37	Z241576 R.TA Nov./27/'24 S.S	ANGLE ±2° 6 OVER 30 MAX. ±0.3	PROJECTION  SERIES No. R11 TITLE MINIDOCK™ Standard Type CONNECTOR RIGHT ANGLE PLUG SCALE 2:1 UNIT mm SHEET 1/5 REV. 37			
36	Z240688 Y.I Jun./06/'24 M.T	6 MAX. ±0.2 30 OVER 120 MAX. ±0.5				
35	Z231261 T.I Oct./19/'23 Y.H	GENERAL TOLERANCE.				
34	Z230123 M.H Feb./22/'23 Y.H	DWG. E.Kawabe DATE 1994/06/27				
33	Z220241 M.H Mar./18/'22 Y.H	CHK. -				
32	Z191328 IMI Oct./01/'19 Y.S	APP. -				
REV.	ECN	BY	DATE	APP.	DWG. No.	30001
REVISION RECORD					Y.Fukuda	

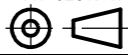
ITEMS	SPECIFICATION
RATING VOLTAGE	250V AC (PER CONTACT PIN)
RATING AMPERAGE (FOR CONTACT)	0.5A AC/DC (PER CONTACT PIN)
OPERATING TEMPERATURE	208~358K(-65°C~+85°C)
OPERATING HUMIDITY	85% MAX.
CONTACT RESISTANCE (FOR CONTACT)	INITIAL : 70mohm MAX. / AFTER TEST : $\triangle$ 25mohm MAX.
INSULATION RESISTANCE	INITIAL : 10,000Mohm MIN. / AFTER TEST : 1,000Mohm MIN.
DIELECTRIC WITHSTANDING VOLTAGE	AC500V 1min
DURABILITY	5,000 CYCLES
MATING FORCE (INITIAL)	0.9N/pos. MAX.
UNMATING FORCE (AFTER TEST)	0.059N/pos. MIN.
COPLANARITY	-
PRODUCT SPECIFICATION	PRS-1011
TEST REPORT	TR-9020
PACKING STANDARD	300-014
INSTRUCTION MANUAL	-
APPEARANCE CRITERIA No.	QLS-A***

ANGLE	$\pm 2^\circ$	6 OVER 30 MAX.	$\pm 0.3$	PROJECTION 	SERIES No. R11	CUSTOMER COPY		
6 MAX.	$\pm 0.2$	30 OVER 120 MAX.	$\pm 0.5$					
GENERAL TOLERANCE.				TITLE MINIDOCK™ Standard Type CONNECTOR RIGHT ANGLE PLUG	SCALE 	<b>I-PEX</b>		
DWG.	DATE							
CHK.								
APP.								
				DWG. No.	30001	SIZE A3	SHEET 2/5	REV. 37

PART No.	POS.	A	B	C	D	G	H	P	J	K	L	M	SCREW	NOTE
30001-100T-F	100P	51.65	42.25	15.24	47.50	37.35	38.85	2.5	2.1	47.52	37.55	52.15	WITHOUT SCREW	-
30001-240T-F	240P	96.10	86.70	37.465	91.95	81.80	83.30	3.1	2.5	91.95	82.00	96.60		GUIDE WALL TYPE
30001-100T-01F	100P	51.65	42.25	15.24	47.50	37.35	38.85	2.5	2.1	47.52	37.55	52.15	WITH SCREW	-
30001-240T-02F	240P	96.10	86.70	37.465	91.95	81.80	83.30	3.1	2.5	91.95	82.00	96.60		GUIDE WALL TYPE

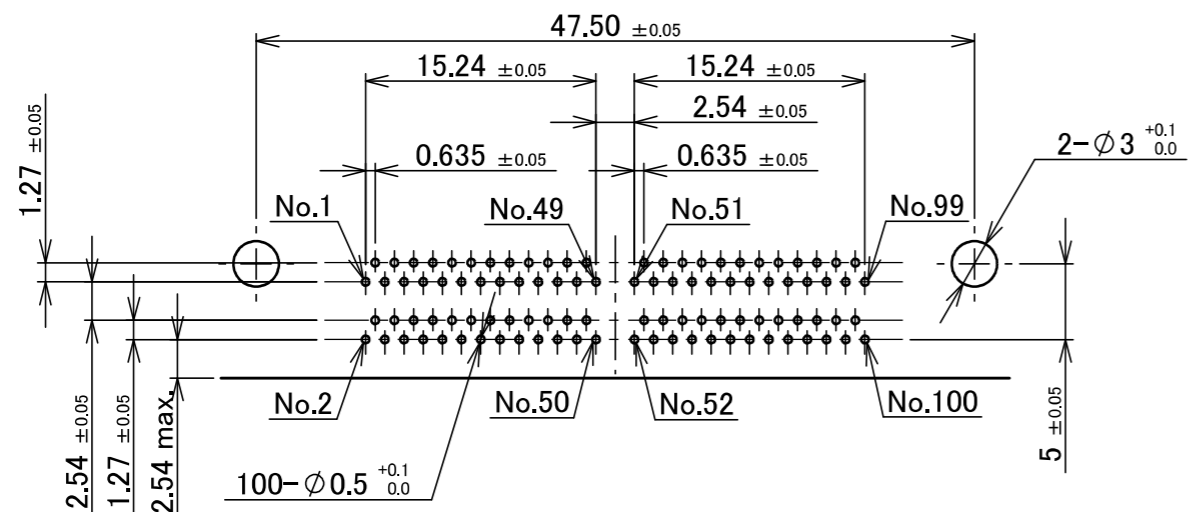

RECOMMENDED FOOTPRINT PATTERN  $t=1.6 \pm 0.1$  (100P ONLY)

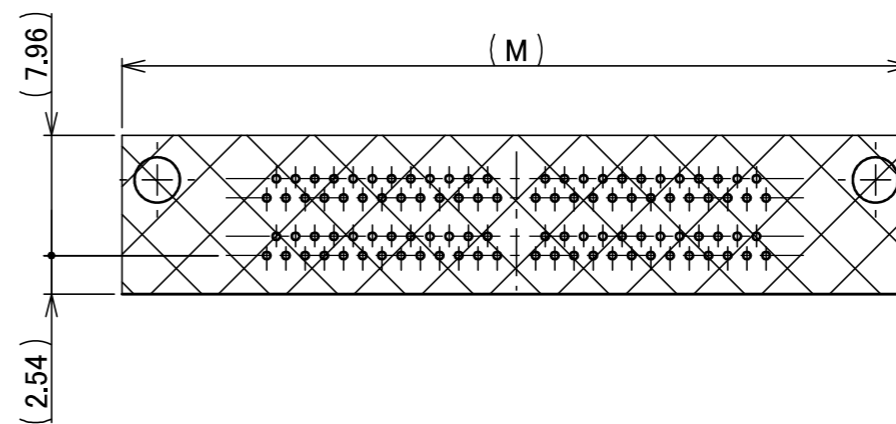

DO NOT MOUNT ANY OTHER COMPONENTS IN THIS AREA

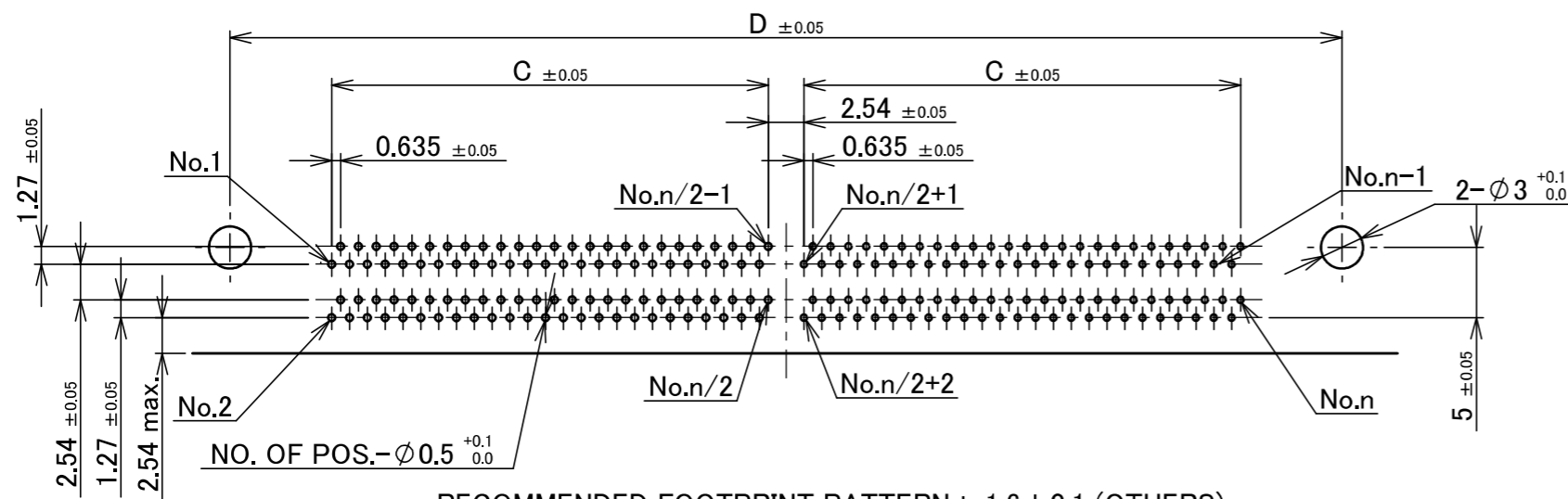

RECOMMENDED FOOTPRINT PATTERN  $t=1.6 \pm 0.1$  (OTHERS)

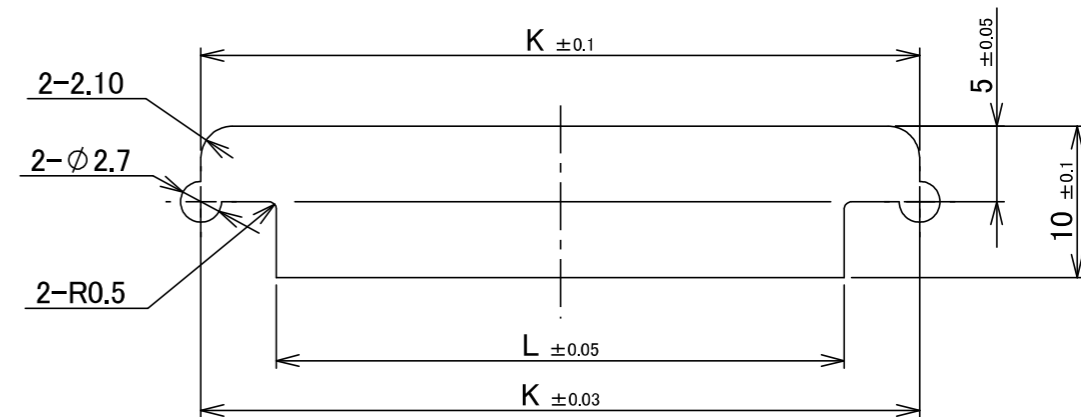

RECOMMENDED OPENING FOR MOUNTING BRACKET

ANGLE	$\pm 2^\circ$	6 OVER 30 MAX.	$\pm 0.3$	PROJECTION	SERIES No.	CUSTOMER COPY
	6 MAX.	$\pm 0.2$	30 OVER 120 MAX.	$\pm 0.5$	R11	
GENERAL TOLERANCE.				TITLE	SCALE	I-PEX
DWG.	DATE			MINIDOCK™ Standard Type CONNECTOR RIGHT ANGLE PLUG	2:1	
CHK.					UNIT	
APP.				DWG. No.	SIZE	SHEET
				30001	A3	3/5
						REV.
						37

PART NO.	Pos.	QTY./ TRAY	QTY./ SHIPPING CARTON	QTY./ PACKING CARTON
30001-240T-F	240P	21	21 × 4 = 84	84 × 4 = 336
30001-240T-02F				

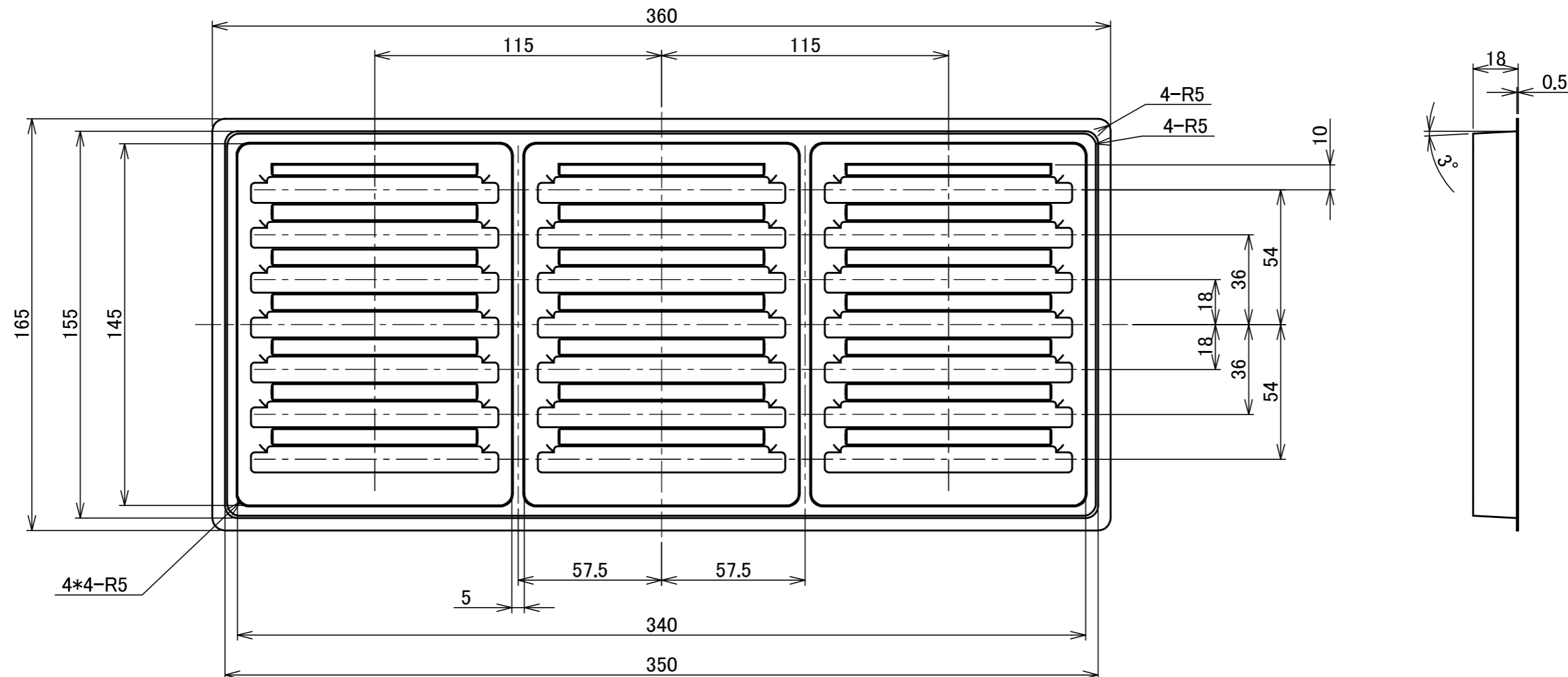

NO.	DISCRIPTION	MATERIAL	FINISH , REMARKS
5	TRAY	PVC	-
6	MAX. ±0.2 30 OVER 120 MAX. ±0.5	PROJECTION	SERIES No. R11
GENERAL TOLERANCE.		TITLE	
DWG.	DATE	MINIDOCK™ Standard Type CONNECTOR RIGHT ANGLE PLUG	
CHK.		SCALE	
APP.		1:X	
		UNIT	
		mm	
		DWG. No.	SIZE SHEET REV.
		30001	A3 4/5 37

PART NO.	Pos.	QTY./ TRAY	QTY./ SHIPPING CARTON	QTY./ PACKING CARTON
30001-100T-F	100P	35	35 × 4 = 140	140 × 4 = 560
30001-100T-01F				

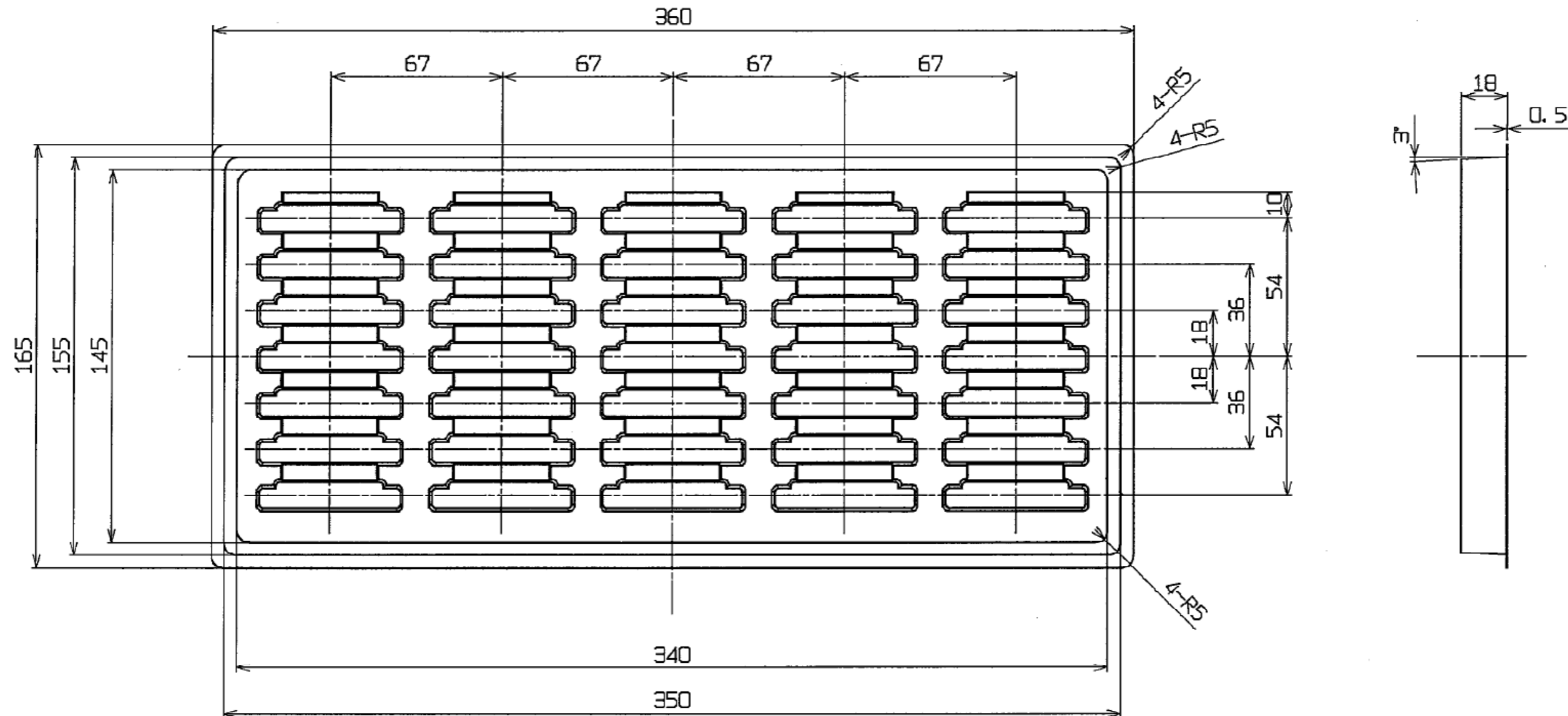

NO.	DISCRIPTION	MATERIAL	FINISH , REMARKS
6	TRAY	PVC	-
ANGLE	±2° 6 OVER 30 MAX.	±0.3	PROJECTION ⊕ ▽
6 MAX.	±0.2 30 OVER 120 MAX.	±0.5	
GENERAL TOLERANCE.		TITLE	SCALE
DWG.	DATE	MINIDOCK™ Standard Type CONNECTOR RIGHT ANGLE PLUG	1:X
CHK.			UNIT
APP.			mm
		DWG. No.	SIZE SHEET REV.
		30001	A3 5/5 37