

PART No.
20351-112R-37



Halogen Free



RoHS Compliant

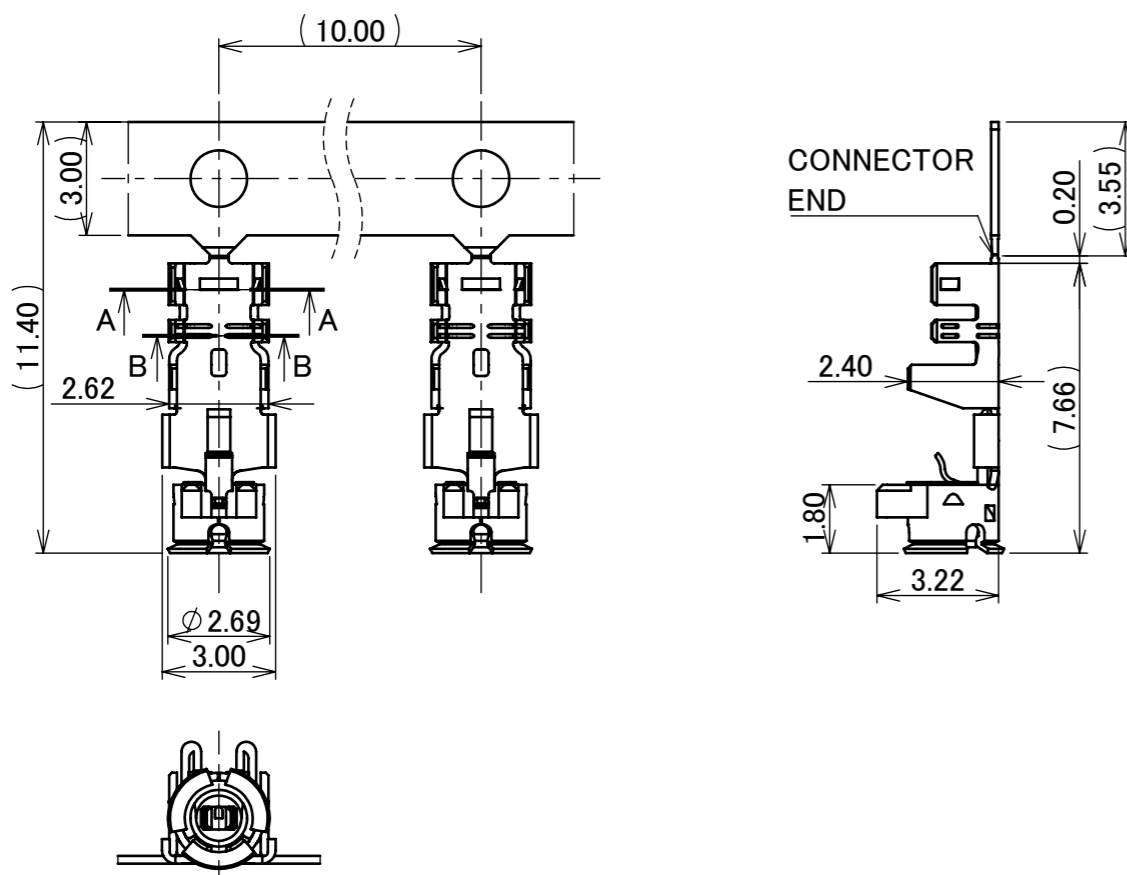
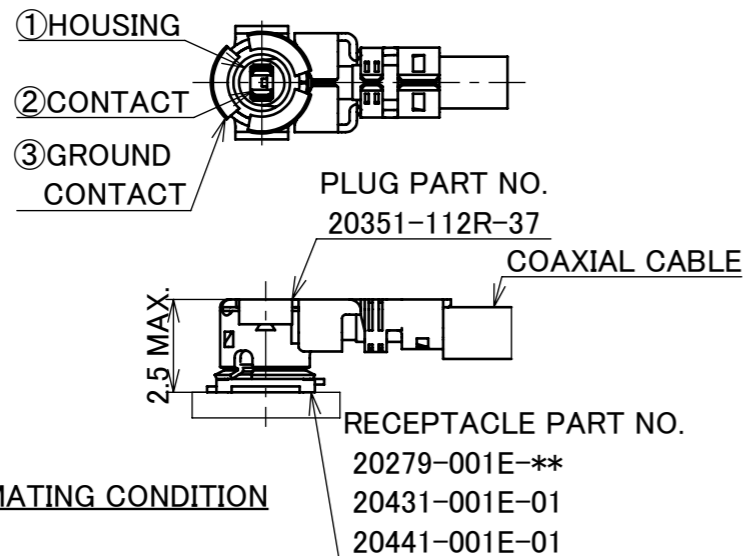
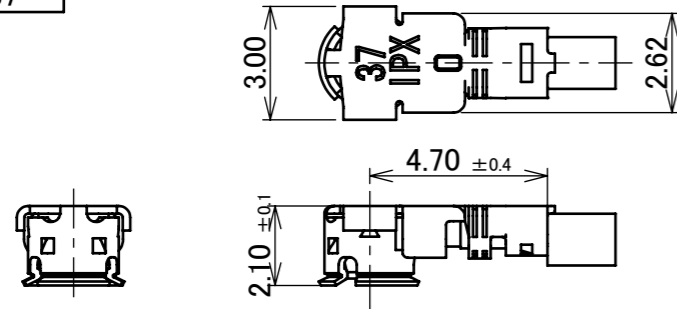
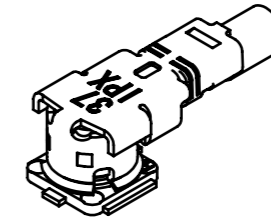

NOTES

1. APPLICABLE CONNECTOR:  
20279-001E-\*\*, 20431-001E-01, 20441-001E-01
2. PERMISSIBLE LOAD OF CABLE AT MATING
3. SUGGESTIONS FOR MATING & UNMATING OPERATION
  - 3-1. MATING  
PLEASE MATE THE CONNECTOR STRAIGHTLY TO VERTICAL DIRECTION AS MUCH AS POSSIBLE, ADJUSTING THE MATING AXIS OF PLUG AND RECEPTACLE. AS EXCESSIVE SLANT ANGLE MATING MAY BREAK THE CONNECTOR, PLEASE DON'T DO IT.
  - 3-2. UNMATING
    - 3-2-1. IN CASE OF UNMATING BY PULLING TOOL  
PLEASE USE THE PULLING TOOL AS THE FOLLOWING DRAWING, AND PLEASE PULL PLUG TO VERTICAL DIRECTION AS DIRECTLY AS POSSIBLE.
    - 3-2-2. IN CASE OF UNMATING DIRECTLY BY HAND  
PLEASE CATCH THE CATCHING AREA OF PLUG, AND PLEASE PULL PLUG TO VERTICAL DIRECTION AS DIRECTLY AS POSSIBLE.
  - 3-3. CRIMP OVER STANDARDS OF OUTER CONDUCTOR  
STANDARDS: LESS THAN 10% FROM TOTAL NUMBERS OF OUTER CONDUCTOR.  
(NUMBERS OF OUTER CONDUCTOR'S CRIMP OVER FROM OUTER CONDUCTOR'S BARREL)
  - 3-4. CAUTION ABOUT HEAT SHRINKAGE TUBES  
PLEASE BE CAREFUL NOT TO MELT HOUSING WHEN USING HEAT SHRINKAGE TUBES. IT WILL BECOME CAUSE OPEN CIRCUIT.
4. TIP OF CONTACT SHOULD BE RECESSED OF HOUSING AFTER CRIMPED ABOUT MATING AREA.
5. THIS IS "Pb-FREE" CONNECTOR.

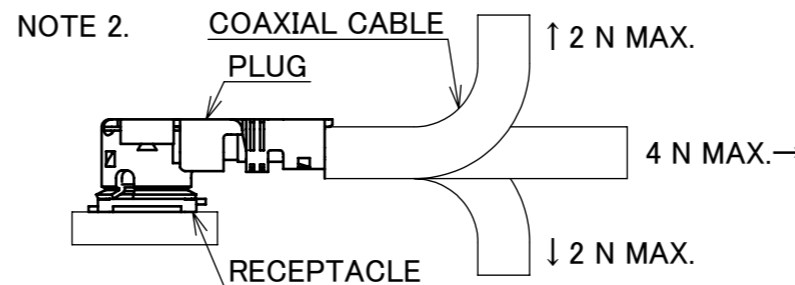

NOTE 3-2-1.

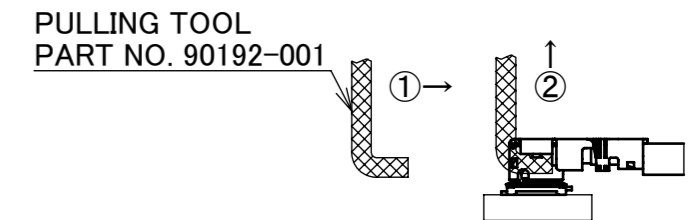

NOTE 3-2-2.

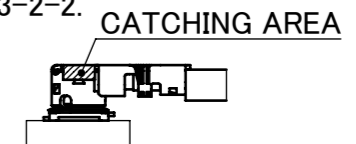

NO.	DESCRIPTION	MATERIAL	FINISH , REMARKS
3	GROUND CONTACT	PHOSPHOR BRONZE	ALL OVER Ni 1.00 μm MIN. CONTACT PART Au 0.05 μm MIN.
2	CONTACT	PHOSPHOR BRONZE	ALL OVER Ni 1.00 μm MIN. CONTACT PART Au 0.10 μm MIN.
1	HOUSING	PBT	UL94V-0, WHITE

REV.	ECN	BY	DATE	APP.	DESCRIPTION	APPROVAL	DATE	PROJECTION	SERIES No.	TITLE	SCALE	SHEET	REV.
21	Z241389	TOI	2024/10/07	Yufu	ANGLE	±2°	6 OVER 30 MAX.	±0.3	R8	MHF® I PLUG (1.37)	5:1	A3	21
20	Z231432	TOI	2023/11/30	Y.H	6 MAX.	±0.2	30 OVER 120 MAX.	±0.5					
19	Z231008	TOI	2023/08/29	Y.H	GENERAL TOLERANCE.								
18	Z210168	S.T	2021/02/19	M.T	DWG.	T.Hirakawa		DATE	2003/09/11				
17	Z200262	TOI	2020/03/05	Y.H	CHK.	T.Harada							
16	Z191013	Haji	2019/08/01	Y.S	APP.	K.Katabuchi							
REVISION RECORD					K.Katabuchi				DWG. No.	20351		1/5	

ITEMS	SPECIFICATION	
RECOMMENDED APPLICABLE CONNECTOR PART No.	20279-001E-**	20441-001E-01
RATING VOLTAGE	60 V AC (R.M.S)	
RATING FREQUENCY	DC~9GHz	
OPERATING TEMPERATURE	233~363 K (-40°C~+90°C)	
VSWR	1.3 MAX. AT 0.1~3 GHz, 1.5 MAX. AT 3~6 GHz, 1.9 MAX. AT 6~9 GHz	
MAIN CONTACT RESISTANCE	INITIAL: 20 mohm MAX. / AFTER TEST: 25 mohm MAX.	
GROUND CONTACT RESISTANCE	INITIAL: 10 mohm MAX. / AFTER TEST: 15 mohm MAX.	
INSULATION RESISTANCE	INITIAL: 500 Mohm MIN. / AFTER TEST: 100 Mohm MIN.	
DIELECTRIC WITHSTANDING VOLTAGE	200 V AC, 1 MINUTE	
DURABILITY	30 CYCLES	
UNMATING FORCE (INITIAL / AFTER TEST)	5 N MIN. / 3 N MIN.	
CRIMP STRENGTH	15 N MIN.	
PRODUCT SPECIFICATION	PRS-1726	
TEST REPORT	TR-12096	
PACKING STANDARD	300-233	
INSTRUCTION MANUAL	HIM-10002	
APPEARANCE CRITERIA No.	QLS-A***	

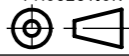
ANGLE	±2°	6 OVER 30 MAX.	±0.3	PROJECTION 	SERIES No. R8	CUSTOMER COPY		
6 MAX.	±0.2	30 OVER 120 MAX.	±0.5					
GENERAL TOLERANCE.				TITLE MHF® I PLUG (1.37)	SCALE -	<b>I-PEX</b>		
DWG.	DATE							
CHK.								
APP.								
				DWG. No.	20351	SIZE A3	SHEET 2/5	REV. 21

APPLICABLE CABLE  
NOMINAL DIMENSION

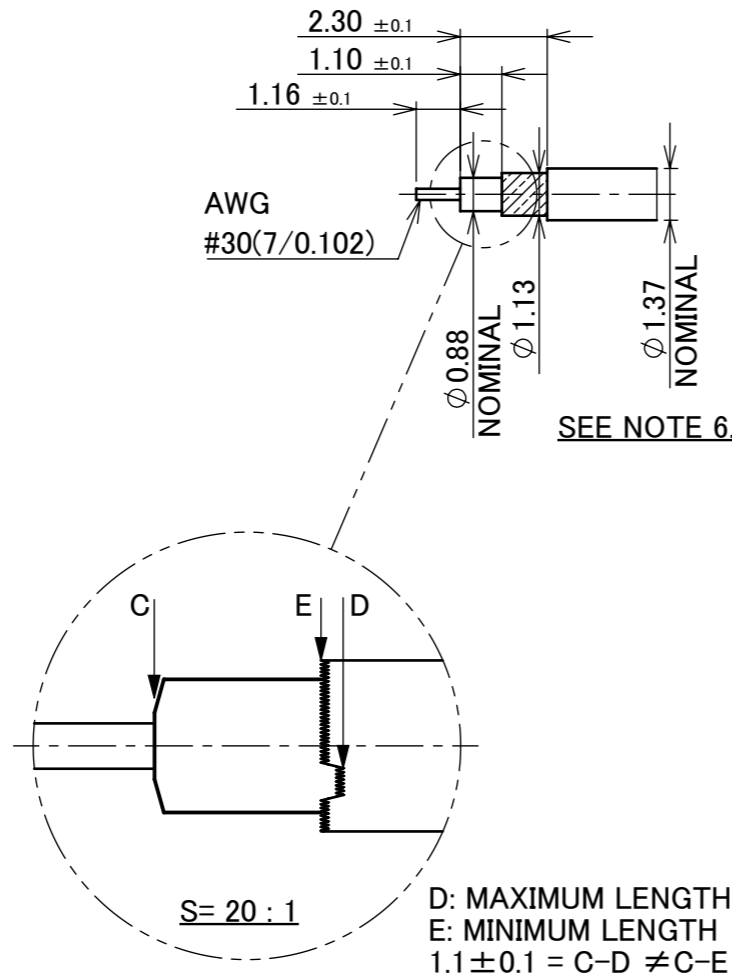
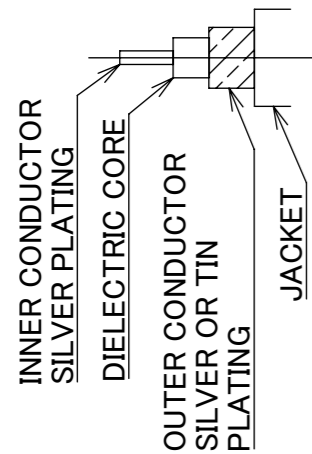

CABLE CUT LENGTH

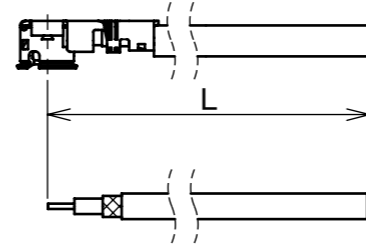

CRIMP HEIGHT

BLADE MICROMETER

CH-1

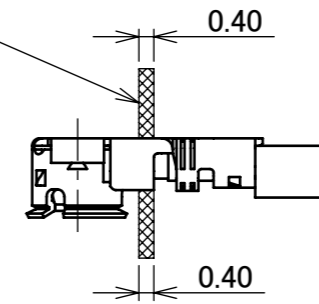
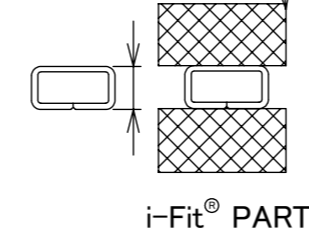

CH-2

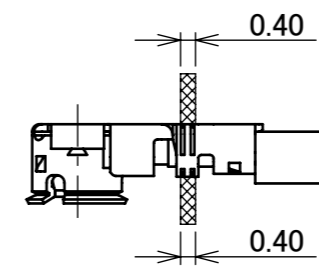
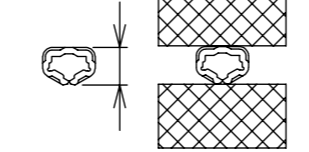

CH-3

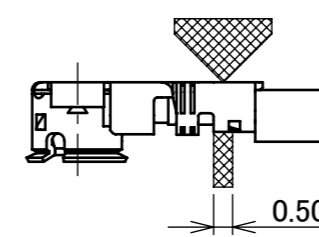
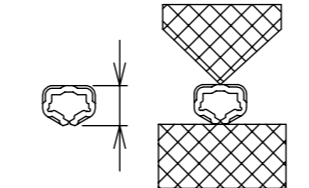

OUTER CONDUCTOR PART

JACKET PART

BRAIDED SHIELD OF  
OUTER CONDUCTOR

SINGLE

PART NO. OF SEMI AUTO  
TERMINATION MACHINE

90232-037

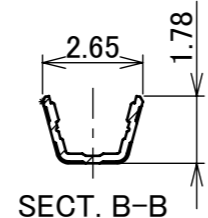
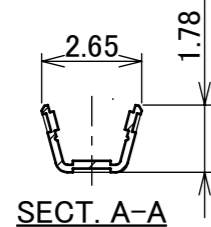

CRIMP  
HEIGHT

CH-1

1.34~1.40

CH-2

1.36~1.42

CH-3

1.28~1.34

ANGLE	$\pm 2^\circ$	6 OVER 30 MAX.	$\pm 0.3$
	6 MAX.	$\pm 0.2$	30 OVER 120 MAX. $\pm 0.5$

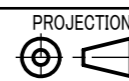

SERIES No.  
R8

CUSTOMER COPY

GENERAL TOLERANCE.

TITLE  
MHF® I  
PLUG (1.37)

SCALE

**I-PEX**

DWG. DATE

UNIT

mm

CHK.

SIZE

SHEET

REV.

APP.

DWG. No. 20351

A3

3/5

21

NOTE 6. DO NOT USE SOLDER COATED EITHER INNER OR OUTER CONDUCTOR CABLE.

Recommended P/N 20351-112R-37

PART NO.	F	QTY. PER EMBOSS REEL (PIECES / REEL)	QTY. PER PACKING CARTON (REELS / CARTON)
20351-112R-37	16.0	2,500 / REEL	5 REELS / CARTON = 12,500 PIECES

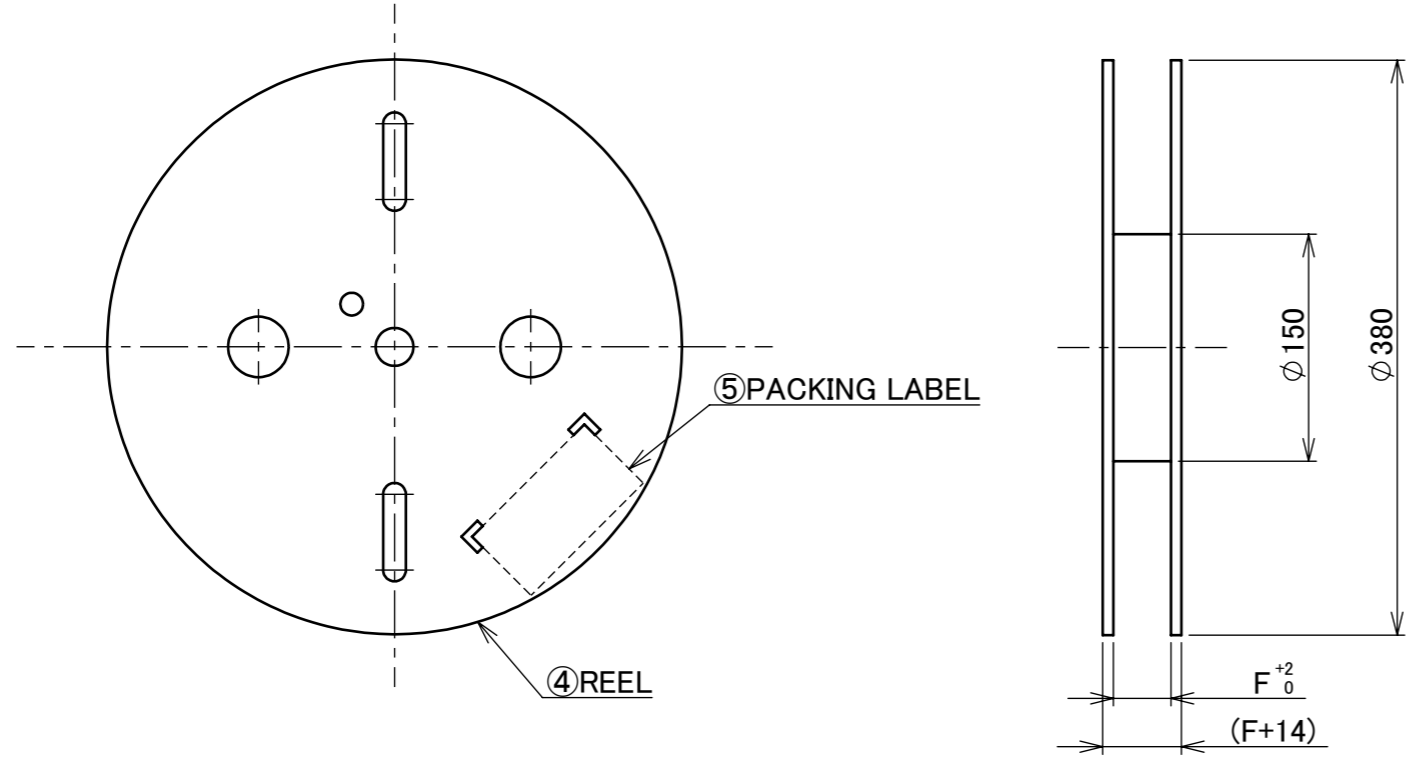

5	PACKING LABEL	-	-
4	REEL	CB	-
NO.	DISCRIPTION	MATERIAL	FINISH , REMARKS

ANGLE	±2°	6 OVER 30 MAX.	±0.3	PROJECTION ⊕	SERIES No. R8	CUSTOMER COPY		
6 MAX.	±0.2	30 OVER 120 MAX.	±0.5					
GENERAL TOLERANCE.				TITLE MHF® I PLUG (1.37)	SCALE -	UNIT <b>I-PEX</b>		
DWG.	DATE							
CHK.								
APP.								
				DWG. No.	20351	SIZE A3	SHEET 4/5	REV. 21

Confidential C

I-PEX Inc.

QKE-DFE06-02 REV.12

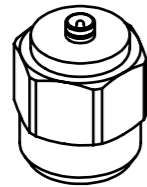

MHF I SMA ADAPTOR  
PART NO. 90193-001

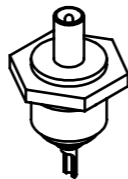

MHF I PLUG INSPECTION CONNECTOR  
PART NO. 90194-001



FRONT SIDE    BACK SIDE  
MHF I UNMATING TOOL  
PART NO. 90192-001

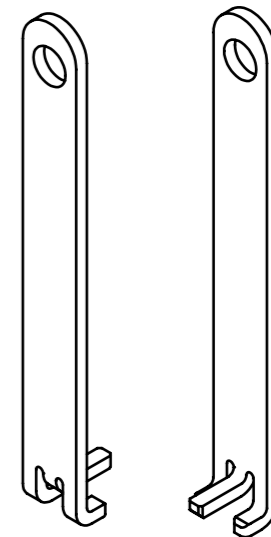

FRONT SIDE    BACK SIDE  
MHF I MATING AND UNMATING TOOL  
PART NO. 90224-001

ANGLE	±2°	6 OVER 30 MAX.	±0.3	PROJECTION ⊕	SERIES No. R8	CUSTOMER COPY				
6 MAX.	±0.2	30 OVER 120 MAX.	±0.5							
GENERAL TOLERANCE.				TITLE MHF® I PLUG (1.37)		SCALE	<b>I-PEX</b>			
DWG.	DATE					2:1				
CHK.						UNIT				mm
APP.						SIZE				SHEET
				DWG. No.	20351	A3	5/5	21		