

Recommended P/N

90286-001

PART NO.

90286-001

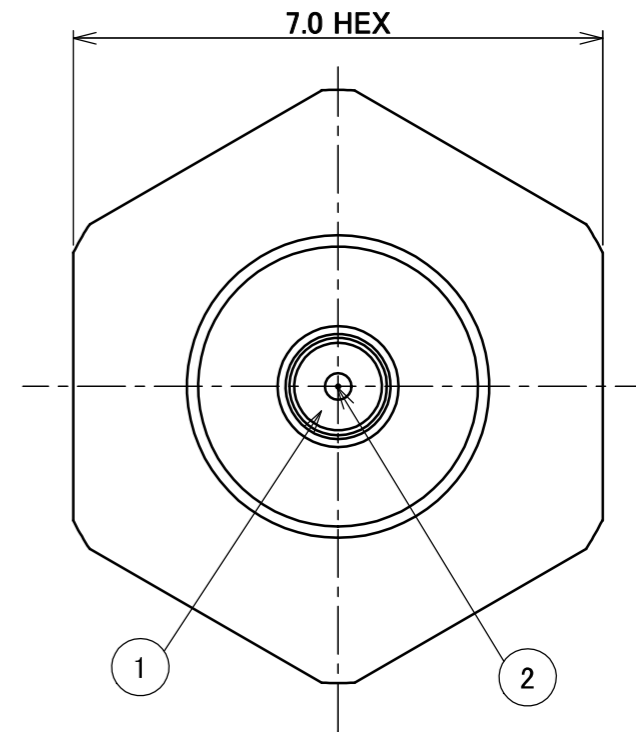
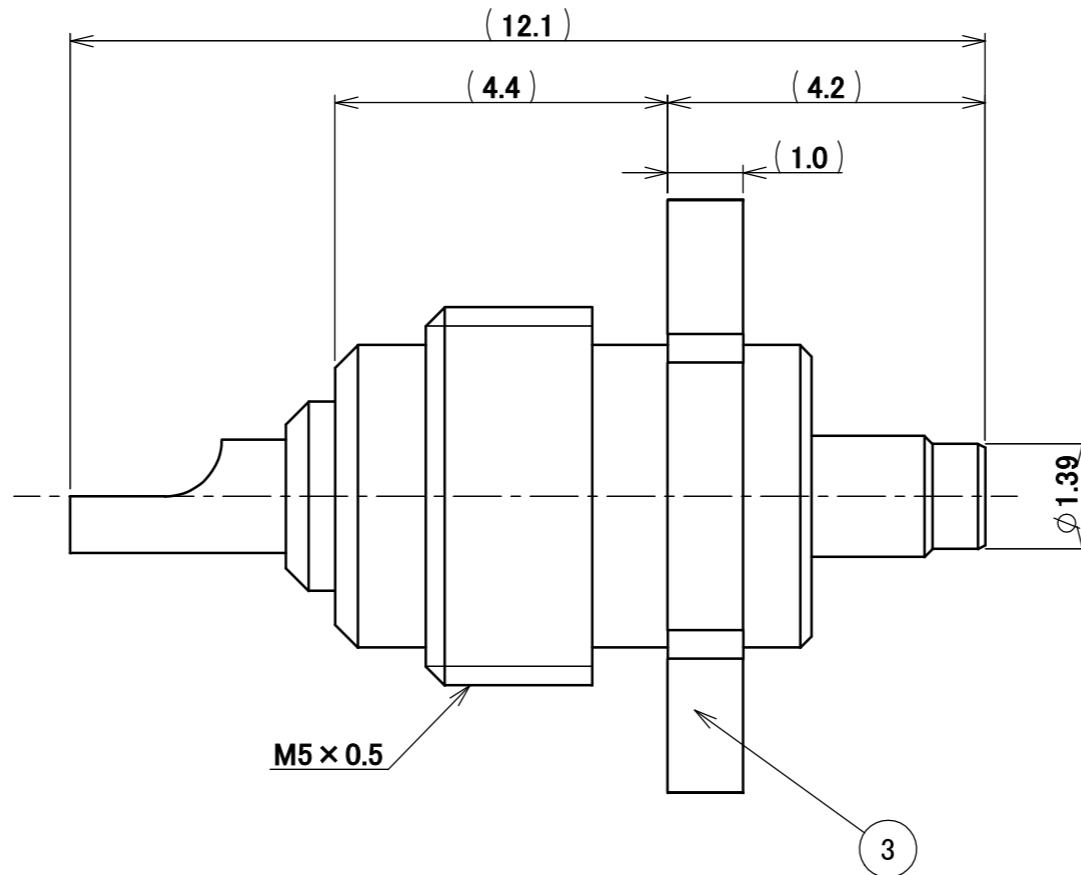
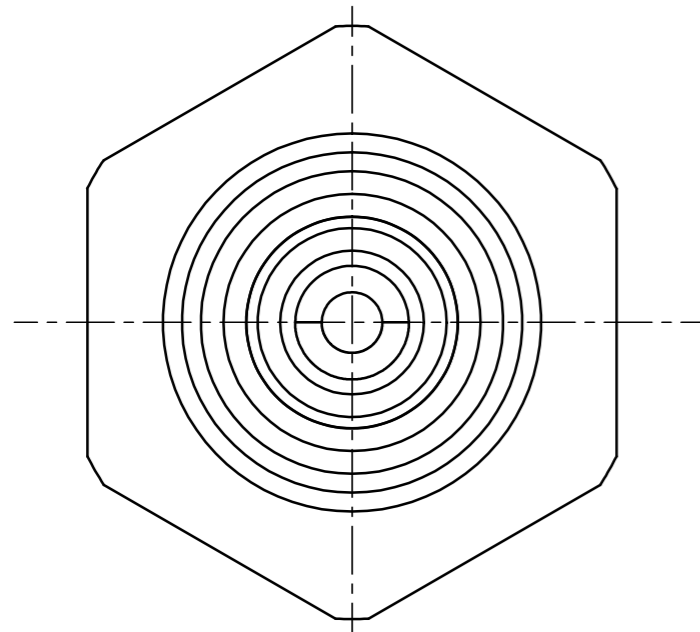
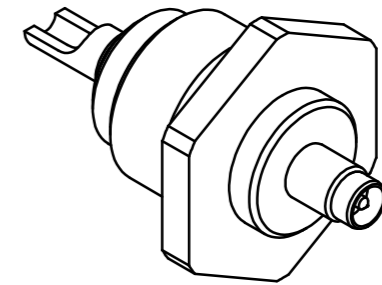
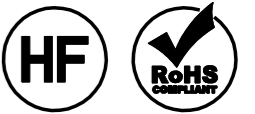

3	SHELL	STAINLESS STEEL	Au 0.3 μ m MIN. OVER Ni 1.0 μ m MIN.
2	CONTACT	BRASS	Au 1.0 μ m MIN. OVER Ni 1.0 μ m MIN.
1	INSULATOR	FLUORINE PLASTICS	
NO.	DESCRIPTION	MATERIAL	FINISH , REMARKS

NOTES.

1. APPLICABLE CONNECTOR PART No.
20367-00*R
2. THIS CONNECTOR IS FOR SHORT CIRCUIT INSPECTION AND DIELECTRIC WITHSTANDING VOLTAGE INSPECTION.

					ANGLE	±2°	6 OVER 30 MAX.	±0.3	PROJECTION	SERIES No.	CUSTOMER COPY	
						6 MAX.	±0.2	30 OVER 120 MAX.	±0.5	R0		
					GENERAL TOLERANCE.				TITLE	SCALE	I-PEX	
					DWG.	DATE			MHF® III PLUG	10:1		
					CHK.	DATE			INSPECTION CONNECTOR	UNIT		
1	Z190562	K.I	2019/04/25	Y.H	T.Hirakawa	2005/01/13				mm		
0	Z05013	TAK	2005/01/13							SIZE		
REV.	ECN	BY	DATE	APP.	APP.	DATE			DWG. No.	A3	SHEET 1/1	REV. 1
REVISION RECORD					E.Kawabe	2005/01/13			90286			