

【AXIAL MISALIGNMENT DISTANCE】

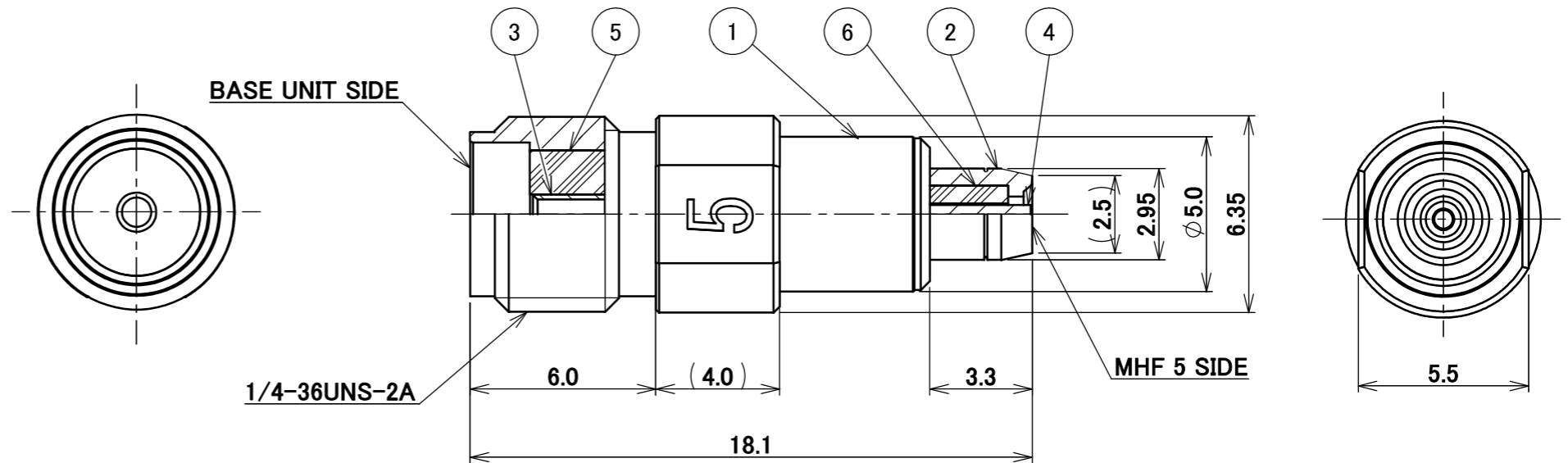
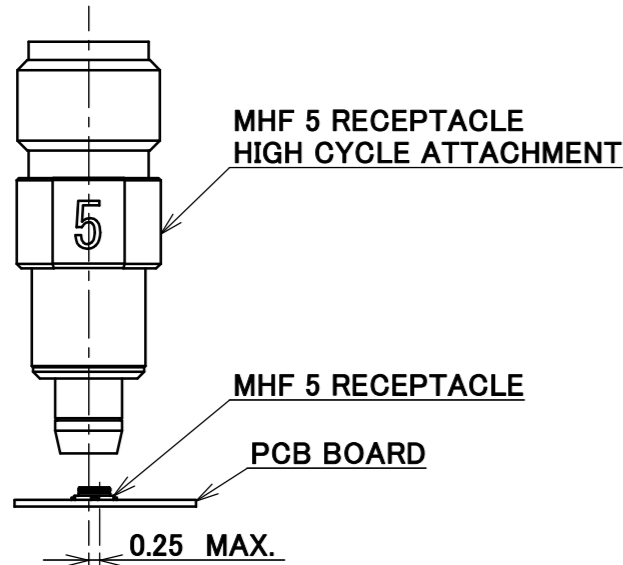

【RECOMMENDED LOAD POSITION】

FLOATING AMOUNT X,Y ±0.1mm

MHF SERIES
HIGH CYCLE
SMA ADAPTER BASE UNIT

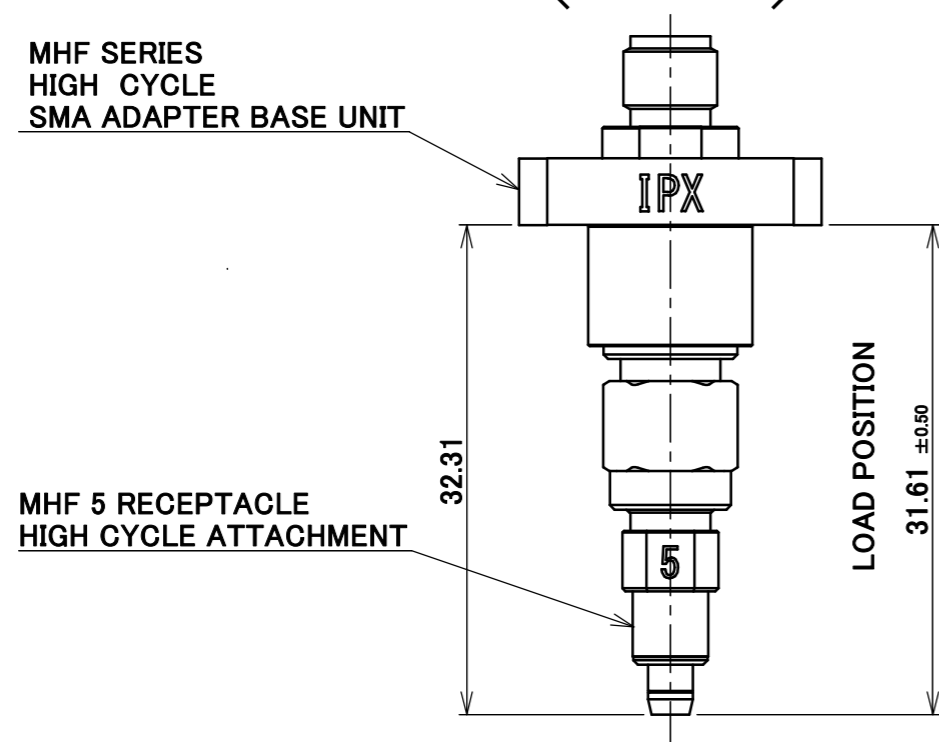

NO.	DESCRIPTION	MATERIAL	FINISH, REMARKS																																																
6	INSULATOR B	PTFE																																																	
5	INSULATOR A	PTFE																																																	
4	PIN CONTACT	BRASS	Au 1.0 μm MIN. OVER Ni 1.0 μm MIN.																																																
3	SOCKET CONTACT	BERYLIUM COPPER	Au 1.0 μm MIN. OVER Ni 1.0 μm MIN.																																																
2	MHF 5 SIDE SHELL	STAINLESS STEEL	Au 1.0 μm MIN. OVER Ni 1.0 μm MIN.																																																
1	SMA JACK SHELL	STAINLESS STEEL	PASSIVATION																																																
<table border="1"> <thead> <tr> <th>NO.</th> <th>DESCRIPTION</th> <th>MATERIAL</th> <th>FINISH, REMARKS</th> </tr> </thead> <tbody> <tr> <td>6</td> <td>INSULATOR B</td> <td>PTFE</td> <td></td> </tr> <tr> <td>5</td> <td>INSULATOR A</td> <td>PTFE</td> <td></td> </tr> <tr> <td>4</td> <td>PIN CONTACT</td> <td>BRASS</td> <td>Au 1.0 μm MIN. OVER Ni 1.0 μm MIN.</td> </tr> <tr> <td>3</td> <td>SOCKET CONTACT</td> <td>BERYLIUM COPPER</td> <td>Au 1.0 μm MIN. OVER Ni 1.0 μm MIN.</td> </tr> <tr> <td>2</td> <td>MHF 5 SIDE SHELL</td> <td>STAINLESS STEEL</td> <td>Au 1.0 μm MIN. OVER Ni 1.0 μm MIN.</td> </tr> <tr> <td>1</td> <td>SMA JACK SHELL</td> <td>STAINLESS STEEL</td> <td>PASSIVATION</td> </tr> </tbody> </table>				NO.	DESCRIPTION	MATERIAL	FINISH, REMARKS	6	INSULATOR B	PTFE		5	INSULATOR A	PTFE		4	PIN CONTACT	BRASS	Au 1.0 μm MIN. OVER Ni 1.0 μm MIN.	3	SOCKET CONTACT	BERYLIUM COPPER	Au 1.0 μm MIN. OVER Ni 1.0 μm MIN.	2	MHF 5 SIDE SHELL	STAINLESS STEEL	Au 1.0 μm MIN. OVER Ni 1.0 μm MIN.	1	SMA JACK SHELL	STAINLESS STEEL	PASSIVATION																				
NO.	DESCRIPTION	MATERIAL	FINISH, REMARKS																																																
6	INSULATOR B	PTFE																																																	
5	INSULATOR A	PTFE																																																	
4	PIN CONTACT	BRASS	Au 1.0 μm MIN. OVER Ni 1.0 μm MIN.																																																
3	SOCKET CONTACT	BERYLIUM COPPER	Au 1.0 μm MIN. OVER Ni 1.0 μm MIN.																																																
2	MHF 5 SIDE SHELL	STAINLESS STEEL	Au 1.0 μm MIN. OVER Ni 1.0 μm MIN.																																																
1	SMA JACK SHELL	STAINLESS STEEL	PASSIVATION																																																
<table border="1"> <thead> <tr> <th>NO.</th> <th>DESCRIPTION</th> <th>MATERIAL</th> <th>FINISH, REMARKS</th> </tr> </thead> <tbody> <tr> <td>3</td> <td>Z190706</td> <td>K.I</td> <td>2019/05/27</td> <td>Y.H</td> <td>GENERAL TOLERANCE.</td> <td rowspan="4"> PROJECTION </td> <td rowspan="4"> SERIES No. R0 </td> <td rowspan="4"> CUSTOMER COPY </td> </tr> <tr> <td>2</td> <td>Z180186</td> <td>Y.I</td> <td>2018/02/16</td> <td>TAK</td> <td>DWG. S.Hamada</td> <td>DATE 2014/02/13</td> <td rowspan="2"> TITLE MHF® 5 RECEPTACLE HIGH CYCLE ATTACHMENT </td> <td rowspan="2"> SCALE 5:1 </td> </tr> <tr> <td>1</td> <td>Z140320</td> <td>S.H</td> <td>2014/04/08</td> <td>Tom</td> <td>CHK. K.Yotsutani</td> <td>DATE 2014/02/13</td> <td>UNIT mm</td> </tr> <tr> <td>0</td> <td>Z140141</td> <td>S.H</td> <td>2014/02/13</td> <td></td> <td>APP. T.Takano</td> <td>DATE 2014/02/13</td> <td>SIZE A3</td> </tr> <tr> <td colspan="6">REVISION RECORD</td> <td>DWG. No.</td> <td>90690</td> <td>SHEET 1/2</td> <td>REV. 3</td> </tr> </tbody> </table>				NO.	DESCRIPTION	MATERIAL	FINISH, REMARKS	3	Z190706	K.I	2019/05/27	Y.H	GENERAL TOLERANCE.	PROJECTION 	SERIES No. R0	CUSTOMER COPY	2	Z180186	Y.I	2018/02/16	TAK	DWG. S.Hamada	DATE 2014/02/13	TITLE MHF® 5 RECEPTACLE HIGH CYCLE ATTACHMENT	SCALE 5:1	1	Z140320	S.H	2014/04/08	Tom	CHK. K.Yotsutani	DATE 2014/02/13	UNIT mm	0	Z140141	S.H	2014/02/13		APP. T.Takano	DATE 2014/02/13	SIZE A3	REVISION RECORD						DWG. No.	90690	SHEET 1/2	REV. 3
NO.	DESCRIPTION	MATERIAL	FINISH, REMARKS																																																
3	Z190706	K.I	2019/05/27	Y.H	GENERAL TOLERANCE.	PROJECTION 	SERIES No. R0	CUSTOMER COPY																																											
2	Z180186	Y.I	2018/02/16	TAK	DWG. S.Hamada				DATE 2014/02/13	TITLE MHF® 5 RECEPTACLE HIGH CYCLE ATTACHMENT	SCALE 5:1																																								
1	Z140320	S.H	2014/04/08	Tom	CHK. K.Yotsutani				DATE 2014/02/13			UNIT mm																																							
0	Z140141	S.H	2014/02/13		APP. T.Takano				DATE 2014/02/13	SIZE A3																																									
REVISION RECORD						DWG. No.	90690	SHEET 1/2	REV. 3																																										

ITEMS	SPECIFICATION
RECOMMENDED APPLICABLE CONNECTOR PART No.	MHF 5 SIDE : MHF 5 RECEPTACLE(P/N : 20566-001E-**) BASE UNIT SIDE : MHF SERIES HIGH CYCLE SMA ADAPTER BASE UNIT (P/N : 90684-0001)
RATING FREQUENCY	DC~6 GHz
OPERATING TEMPERATURE	233~358 K (-30°C~+70°C)
VSWR	1.2 MAX. (DC~6GHz)
INSULATION RESISTANCE	500 Mohm MIN.
DIELECTRIC WITHSTANDING VOLTAGE	AC 300V 1min
DURABILITY	10,000CYCLES
PRODUCT SPECIFICATION	-
TEST REPORT	-
INSTRUCTION MANUAL	HIM-14021

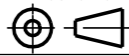
ANGLE	±2°	6 OVER 30 MAX.	±0.3	PROJECTION 	SERIES No. R0	CUSTOMER COPY
6 MAX.	±0.2	30 OVER 120 MAX.	±0.5			
GENERAL TOLERANCE.				TITLE MHF® 5 RECEPTACLE HIGH CYCLE ATTACHMENT	SCALE 5:1	UNIT mm
DWG.	DATE					
CHK.	DATE					
APP.	DATE					
				DWG. No. 90690	SIZE A3	SHEET 2/2 REV. 3