

Recommended P/N

20632-001R-37

PART No.

20632-001R-37

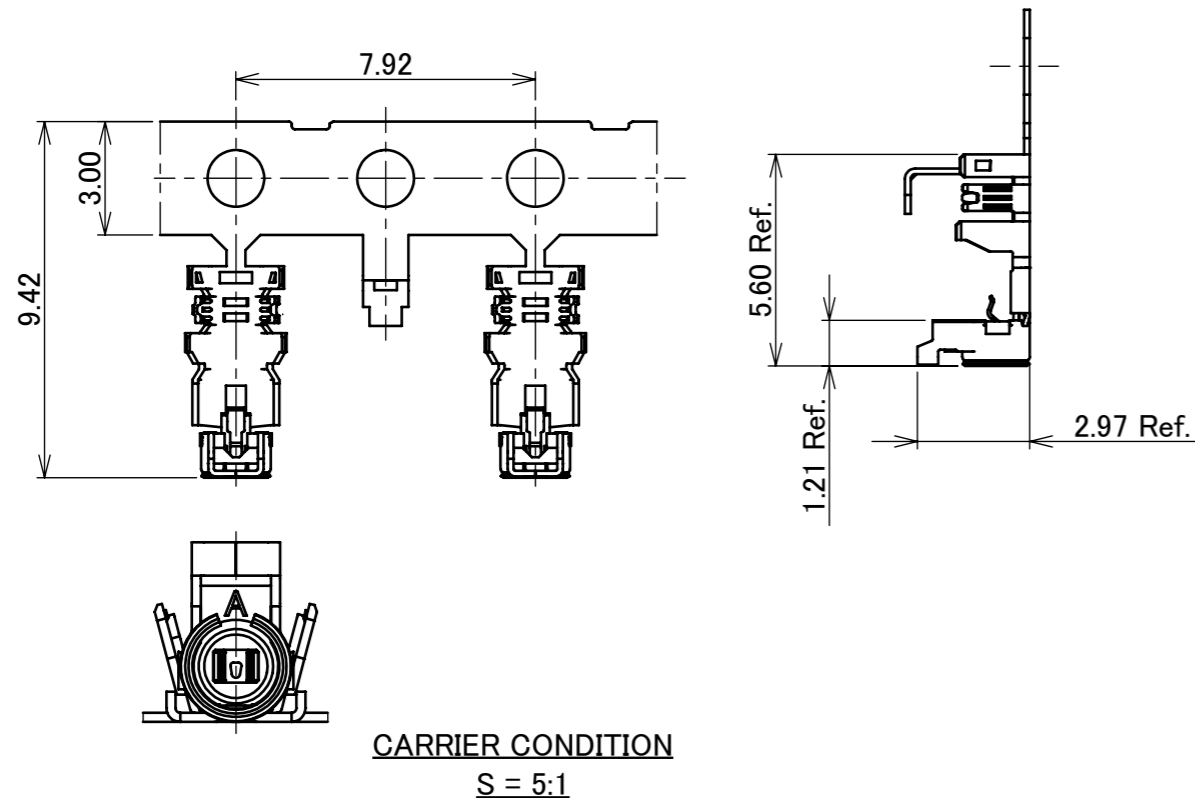
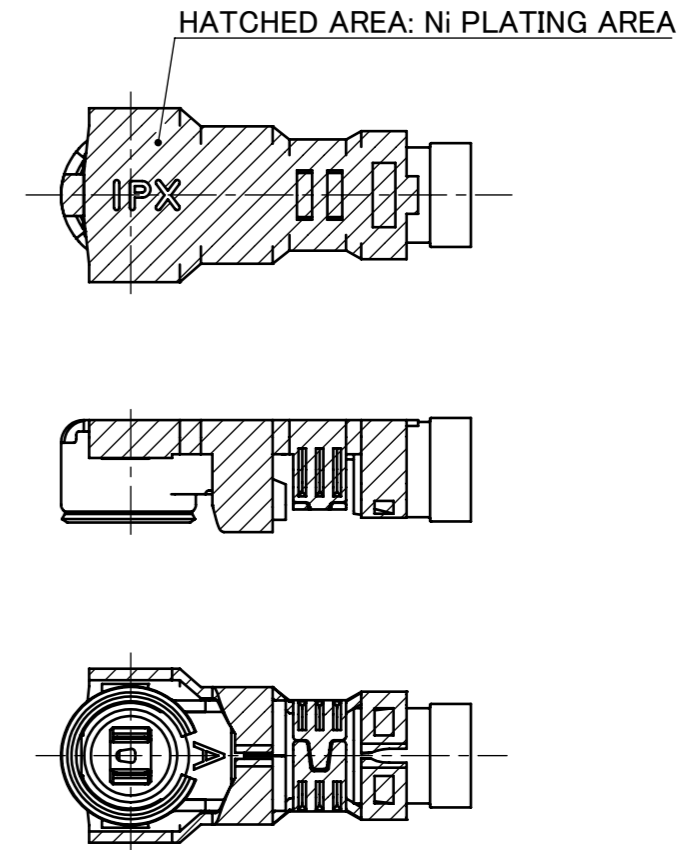
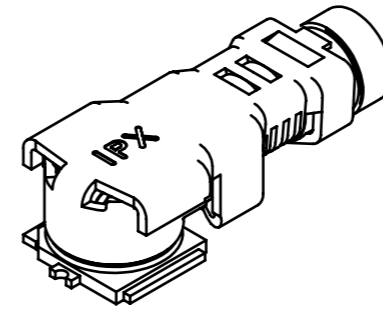
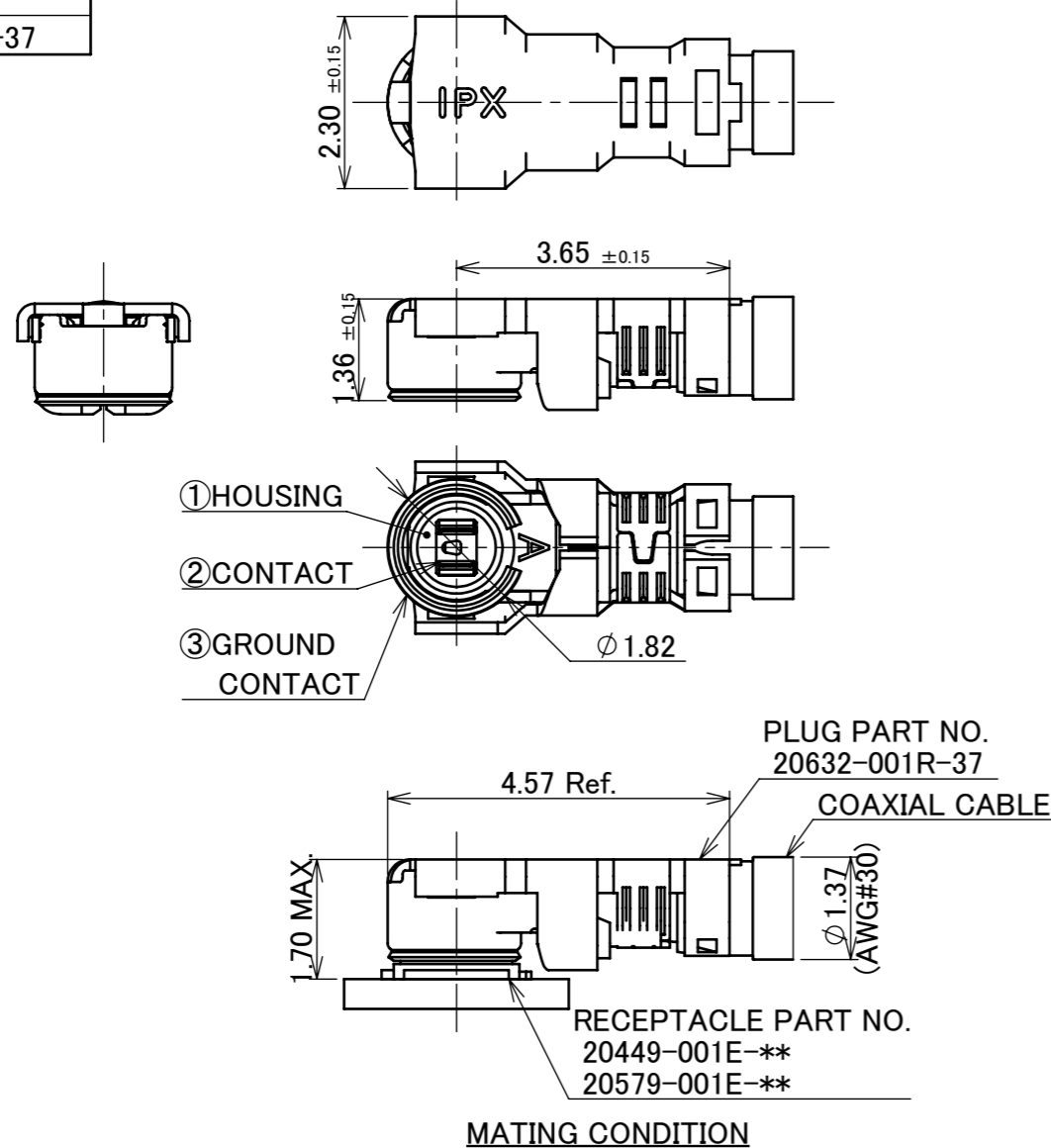

NOTES.

1. APPLICABLE CONNECTOR
20449-001E-**,
20579-001E-**

NO.	DESCRIPTION	MATERIAL	FINISH, REMARKS
3	GROUND CONTACT	PHOSPHOR BRONZE	ALL OVER Ni 1.00 μm MIN. CONTACT PART Au 0.05 μm MIN. [Ni PLATING AREA] Ni ONLY
2	CONTACT	PHOSPHOR BRONZE	ALL OVER Ni 1.00 μm MIN. CONTACT PART Au 0.10 μm MIN.
1	HOUSING	PBT	UL94V-0, BLACK (GF 10%)

REV.	ECN	BY	DATE	APP.	APP.	DATE	DWG. No.	20632	SIZE	SHEET	REV.
5	Z201284	TOI	2020/12/17	M.T	ANGLE	±2°	6 OVER 30 MAX.	±0.3	PROJECTION	SERIES No.	CUSTOMER COPY
4	Z200135	SEI	2020/01/31	Y.S	6 MAX.	±0.2	30 OVER 120 MAX.	±0.5	⊕	R1	
3	Z191019	Haji	2019/08/01	Y.S	GENERAL TOLERANCE.			TITLE	MHF® 4L		
2	Z180749	M.N	2018/11/07	Ken	DWG.	S.Suzuki	DATE	2015/02/23	PLUG Ni TOP (1.37)		
1	Z171403	M.N	2017/12/01	Ken	CHK.	K.Yotsutani	DATE	2015/02/24	SCALE	10:1	
0	Z150197	S.S	2015/02/23		APP.	T.Takano	DATE	2015/02/24	UNIT	I-PEX	
									mm		
									SIZE	SHEET	REV.
									A3	1/5	5

ITEMS	SPECIFICATION	
RECOMMENDED APPLICABLE CONNECTOR PART No.	20449-001E-**	20579-001E-**
RATING VOLTAGE	60 V AC (R.M.S)	
RATING FREQUENCY	DC~12 GHz	
OPERATING TEMPERATURE	233~363K (-40°C~+90°C)	
VSWR	1.3 MAX. AT DC~3 GHz, 1.4 MAX. AT 3~6 GHz, 1.5 MAX. AT 6~9 GHz, 1.6 MAX. AT 9~12 GHz	
MAIN CONTACT RESISTANCE	INITIAL: 20 mohm MAX. / AFTER TEST: Δ R 20 mohm MAX.	
GROUND CONTACT RESISTANCE	INITIAL: 20 mohm MAX. / AFTER TEST: Δ R 20 mohm MAX.	
INSULATION RESISTANCE	INITIAL: 500 Mohm MIN. / AFTER TEST: 100 Mohm MIN.	
DIELECTRIC WITHSTANDING VOLTAGE	200 V AC, 1 MINUTE	
DURABILITY	30 CYCLES	
MATING FORCE (INITIAL / AFTER TEST)	INITIAL: 30 N MAX. / AFTER TEST: 30 N MAX.	
UNMATING FORCE (INITIAL / AFTER TEST)	INITIAL: 20 N MAX. 5 N MIN. / AFTER TEST: 20 N MAX. 3 N MIN.	
PRODUCT SPECIFICATION	PRS-2008	PRS-1907
TEST REPORT	TR-14100	TR-14097
PACKING STANDARD	PST-12066	
INSTRUCTION MANUAL	HIM-16011	
APPEARANCE CRITERIA No.	QLS-A***	

ANGLE	$\pm 2^\circ$	6 OVER 30 MAX.	± 0.3	PROJECTION 	SERIES No. R1	CUSTOMER COPY		
6 MAX.	± 0.2	30 OVER 120 MAX.	± 0.5					
GENERAL TOLERANCE.				TITLE MHF [®] 4L PLUG Ni TOP (1.37)	SCALE -	I-PEX		
DWG.	DATE							
CHK.								
APP.								
				DWG. No.	20632	SIZE A3	SHEET 2/5	REV. 5

PART NO.	20632-001R-37		
APPLICABLE CABLE STRIP DIMENSION	<p>*DO NOT USE SOLDER COATED EITHER INNER OR OUTER CONDUCTOR CABLES.</p>		
INNER CONDUCTOR DIELECTRIC CORE OUTER CONDUCTOR JACKET	<p>REQUIREMENTS</p> <p>CHARACTERISTIC IMPEDANCE: 50(±2) ohm BY TDR METHOD</p> <p>NOMINAL CAPACITANCE: 98pF/m</p> <p>CONDUCTOR RESISTANCE OF INNER CONDUCTOR: 320 ohm/km</p> <p>INSULATION RESISTANCE: 1500 Mega-ohm. km MIN.</p> <p>DIELECTRIC WITH STANCE VOLTAGE: NO BREAKDOWN AT 1500 V AC FOR 1 MINUTE.</p>		
BRAIDED SHIELD OF OUTER CONDUCTOR	SINGLE BRAIDED SHIELD		
PART NO. OF SEMI AUTO TERMINATION MACHINE	90703-037		
CRIMP HEIGHT	<p>CH-1 (i-Fit® PART) 1.46~1.50</p>	<p>CH-2 (SHIELD PART) 1.16~1.20</p>	<p>CH-3 (JACKET PART) 1.27~1.31</p>
	※USE FOR POINT MICROMETER.		

NOTES 2.
DESCRIPTION

INNER CONDUCTOR	AWG#30 (7/0.102) SILVER PLATING ANNEALED COPPER WIRE
DIELECTRIC CORE	FLUORO-PLASTICS, DIAMETER 0.88(+0.04/-0.02)mm NOMINAL THICKNESS 0.29mm
OUTER CONDUCTOR	16/5/0.05, NOMINAL DIAMETER 1.13mm TIN-COATED ANNEALED COPPER WIRE.
JACKET	FLUORO-PLASTICS, DIAMETER 1.37±0.08mm NOMINAL THICKNESS 0.12mm

ANGLE	±2°	6 OVER 30 MAX.	±0.3	PROJECTION	SERIES No.	CUSTOMER COPY
	6 MAX.	±0.2	30 OVER 120 MAX.	±0.5	R1	
GENERAL TOLERANCE.				TITLE	SCALE	I-PEX
DWG.	DATE			MHF® 4L PLUG Ni TOP (1.37)	-	
CHK.				DWG. No.	UNIT	mm
APP.				20632	mm	
				SIZE	SHEET	REV.
				A3	3/5	5

PART NO.	A	QTY. PER EMBOSS REEL (PIECES / REEL)	QTY. PER PACKING CARTON (REELS / CARTON)
20632-001R-37	15	3,000 / REEL	7 REELS / CARTON = 21,000 PIECES

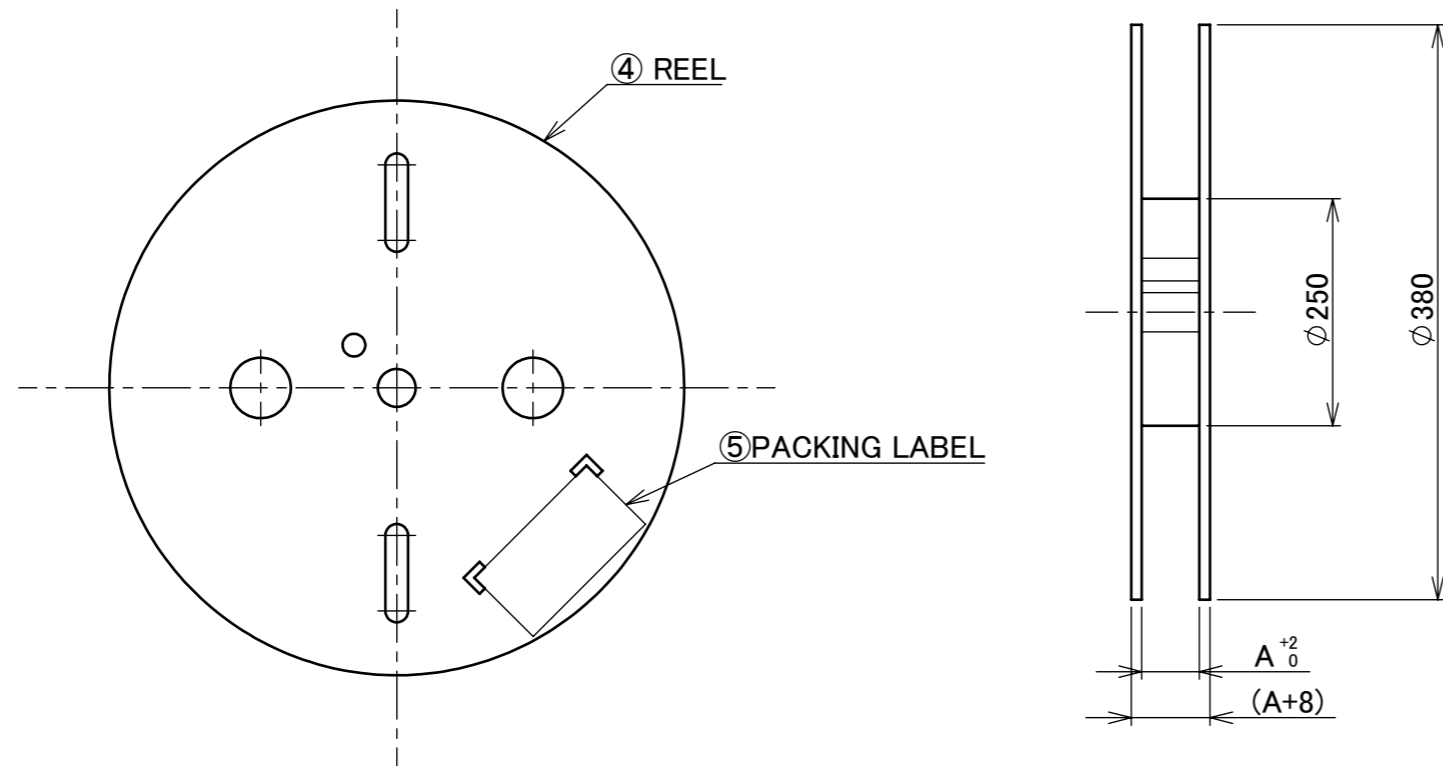

5	PACKING LABEL	-	-
4	REEL	PP	-
NO.	DISCRIPTION	MATERIAL	FINISH , REMARKS

ANGLE	$\pm 2^\circ$	6 OVER 30 MAX.	± 0.3	PROJECTION 	SERIES No. R1	CUSTOMER COPY				
6 MAX.	± 0.2	30 OVER 120 MAX.	± 0.5							
GENERAL TOLERANCE.				TITLE	SCALE	I-PEX				
DWG.	DATE			MHF® 4L PLUG Ni TOP (1.37)	-					
CHK.					UNIT				mm	
APP.				DWG. No.	SIZE				SHEET	REV.
				20632	A3	4/5	5			

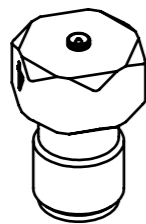

MHF 4 (4L) SMA ADAPTOR
PART NO. 90449-001

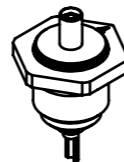

MHF 4 (4L) INSPECTION CONNECTOR
PART NO. 90449-003-01

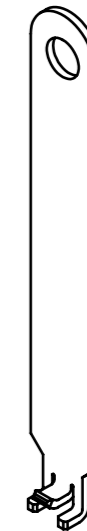

FRONT SIDE BACK SIDE
MHF 4L (1.37) PUSHING AND PULLING TOOL
PART NO. 90873-0001

ANGLE	±2°	6 OVER 30 MAX.	±0.3	PROJECTION ⊕	SERIES No. R1	CUSTOMER COPY			
6 MAX.	±0.2	30 OVER 120 MAX.	±0.5						
GENERAL TOLERANCE.				TITLE		SCALE	I-PEX		
DWG.	DATE			MHF® 4L PLUG Ni TOP (1.37)		2:1			
CHK.						UNIT			
APP.				DWG. No. 20632		mm			
						SIZE	SHEET	REV.	
						A3	5/5	5	