

PART NO.	L
8-24-0128	500.00±5.0 mm

PLEASE CONTACT I-PEX FOR REQUESTS OTHER THAN THIS SPECIFICATIONS.
PLEASE NOTE IF SPECIFICATIONS CHANGE, PART NO. WILL ALSO CHANGE.

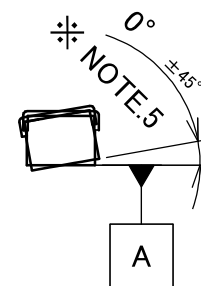
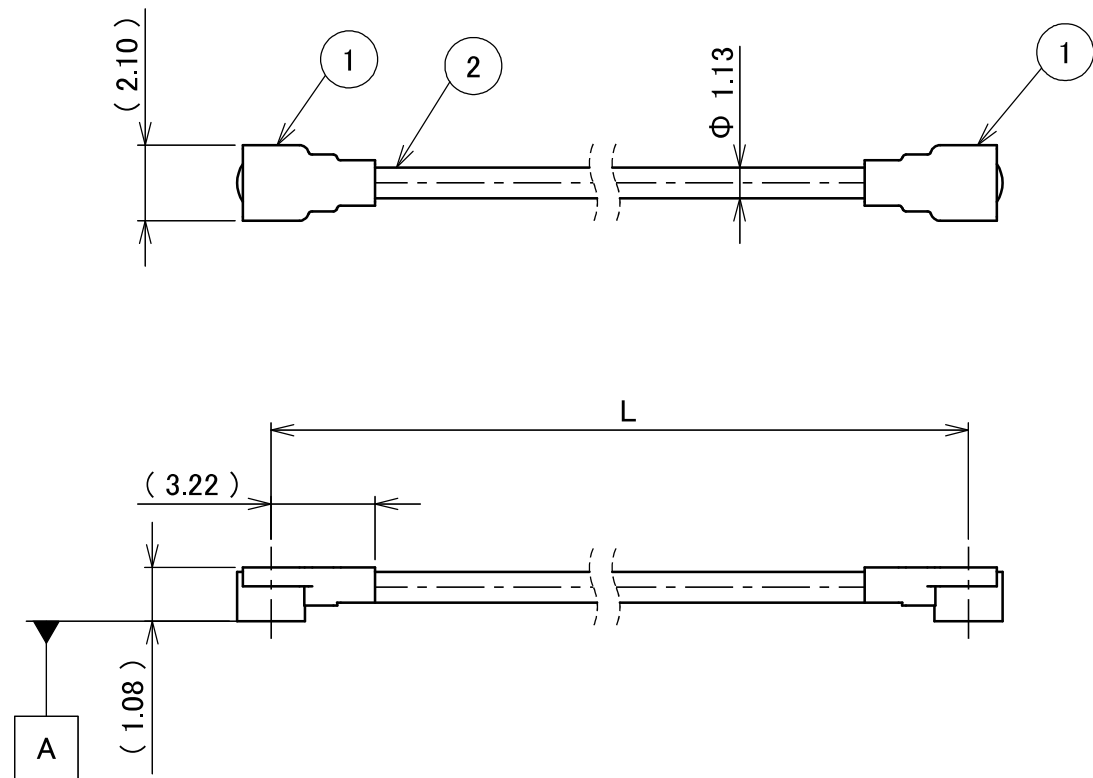

NOTES

1. SUGGESTIONS FOR MATING & UNMATING OPERATION.
 - 1-1. MATING
MATE THE CONNECTOR VERTICALLY, ALIGNING THE MATING AXIS ON PLUG AND RECEPTACLE. DO NOT SLANT MATE.
 - 1-2. UNMATING
 - 1-2-1. UNMATING BY PULLING TOOL.
[P/N 90609-0001 (MHF 4L),]
USE THE PULLING TOOL AS THE FOLLOWING, AND PULL PLUG TO VERTICAL DIRECTION AS DIRECTLY AS POSSIBLE.
 - 1-2-2. UNMATING DIRECTLY BY HAND.
HOLD THE CATCHING AREA ON PLUG AND PULL THE PLUG VERTICALLY.

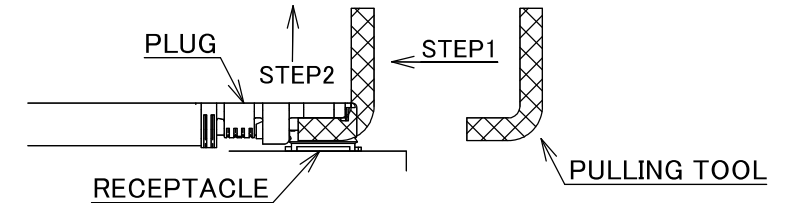

- 1-2-2. UNMATING DIRECTLY BY HAND.
HOLD THE CATCHING AREA ON PLUG AND PULL THE PLUG VERTICALLY.

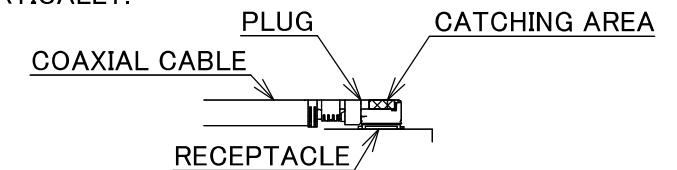

2. PACKING : PLASTIC BAG

3. PERMISSIBLE LOAD ON THE CABLE AFTER MATING

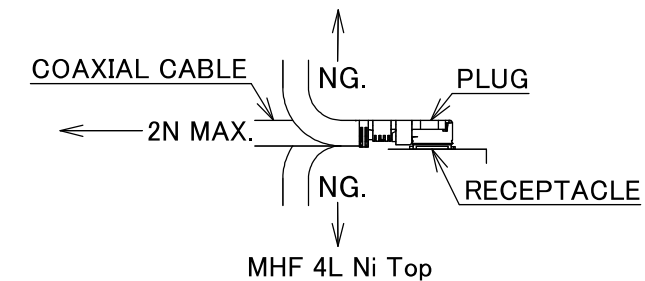

4. CABLE CRIMP STRENGTH : 15N MIN.
5. ORIENTATION OF CONNECTORS

2	CABLE	1	AWG#32 Φ 1.13, BRAIDED SHIELD , BLACK
1	CONNECTOR-1, 2	2	MHF 4L Ni Top
NO.	DESCRIPTION	QTY	REMARK

ANGLE	±2°	6 OVER 30 MAX.	±0.3	PROJECTION ⊕	SERIES No. H-240008A	CUSTOMER COPY
	6 MAX.	±0.2	30 OVER 120 MAX.			
GENERAL TOLERANCE.				TITLE MHF® 4L-4L CABLE113-1	SCALE X:1 UNIT mm	I-PEX
DWG.	M.Toida	DATE	2024/03/21			
CHK.	T.Takuno			DWG. No. 8-24-0128	SIZE A3	SHEET 1/1
REV.	ECN	BY	DATE			
REVISION RECORD				K.Yufu		



Halogen Free



RoHS Compliant