

PART No.
91097-0001

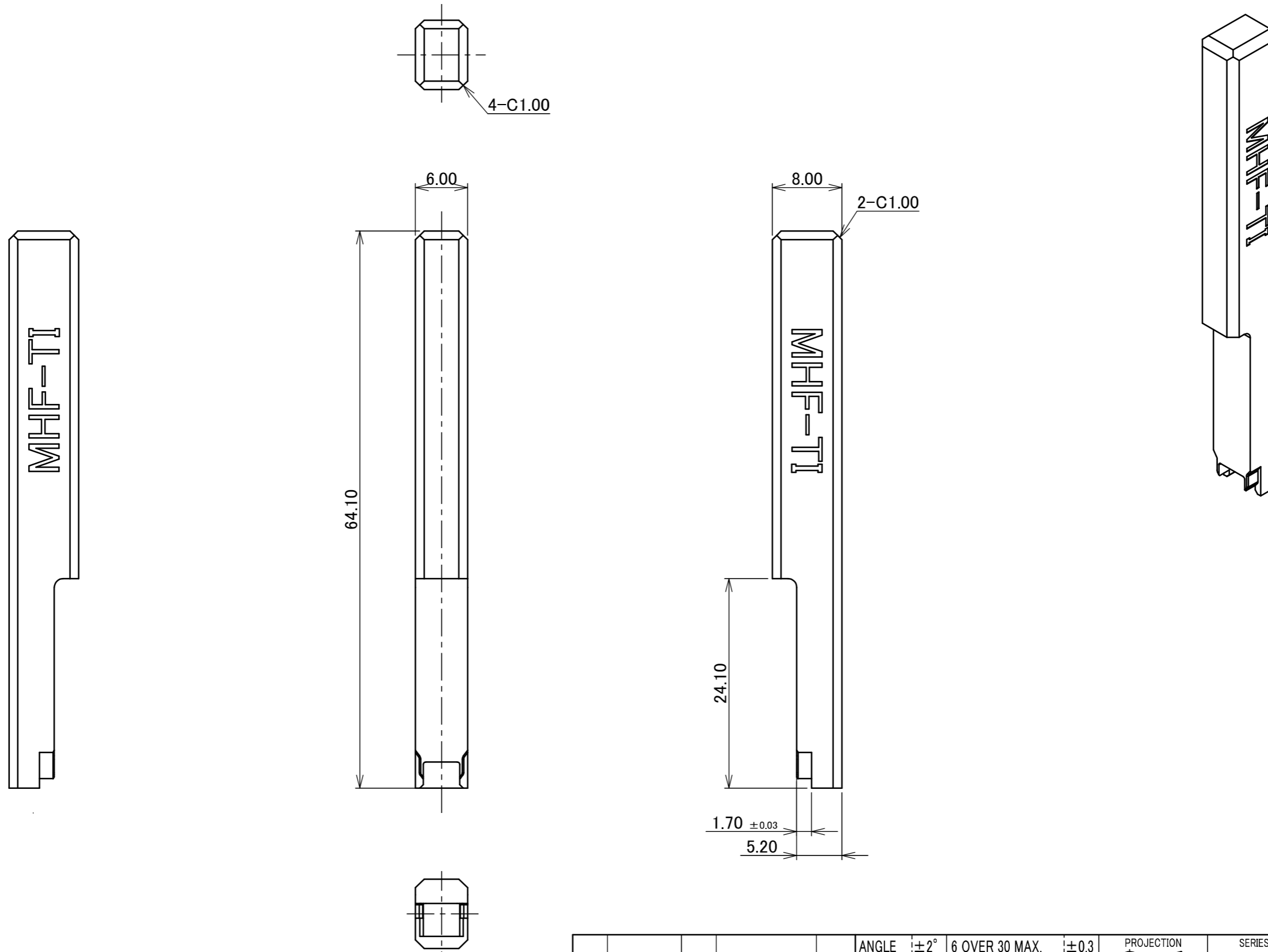

NOTES.
1. MATERIAL : SKD11 HRC55-57

					ANGLE	±2°	6 OVER 30 MAX.	±0.3	PROJECTION	SERIES No.	CUSTOMER COPY			
						6 MAX.	±0.2	30 OVER 120 MAX.	±0.5	RO	I-PEX			
GENERAL TOLERANCE.									TITLE	MHF® -TI UN-MATING JIG				
1	Z231454	K.W	2023/12/06	Y.H	DWG.	T.Yamauchi		DATE	2018/04/18		SCALE	2:1		
0	Z180505	T.Y	2018/04/18		CHK.	-					UNIT	mm		
REV.	ECN	BY	DATE	APP.	APP.	K.Yotsutani		DATE	2018/04/18		SIZE	SHEET	REV.	
REVISION RECORD									DWG. No.	91097		A3	1/1	1