

Recommended P/N

90582-0300

|            |         |
|------------|---------|
| PART No.   | L       |
| 90582-0300 | 300[mm] |
| 90582-0400 | 400[mm] |



Halogen Free



RoHS Compliant

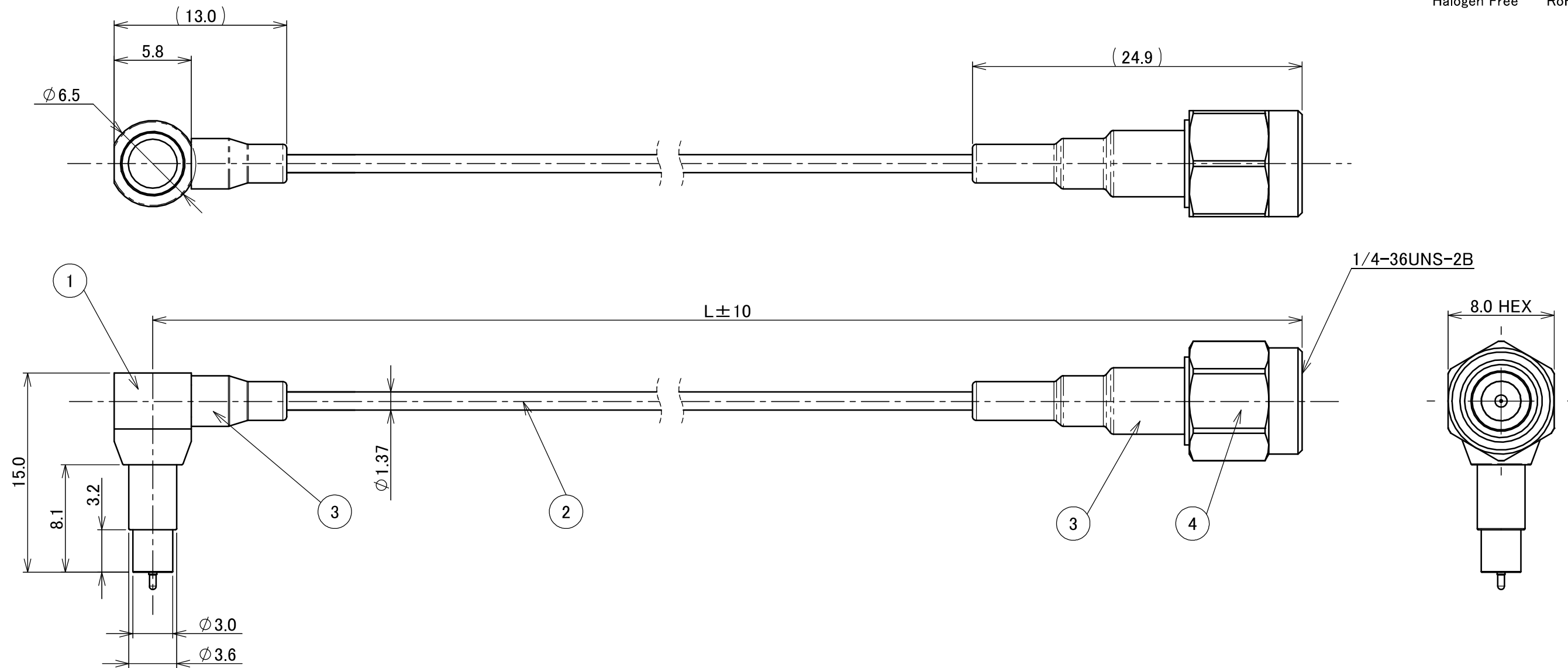

|     |                      |          |                 |
|-----|----------------------|----------|-----------------|
| 4   | SMA-PLUG             | -        |                 |
| 3   | HEAT SHRINKABLE TUBE | -        | BLACK           |
| 2   | COAXIAL CABLE        | -        | BLACK           |
| 1   | INSPECTION PROBE     | -        |                 |
| NO. | DESCRIPTION          | MATERIAL | FINISH, REMARKS |



|      |         |      |            |      |                     |          |                  |          |  |                            |               |           |
|------|---------|------|------------|------|---------------------|----------|------------------|----------|--|----------------------------|---------------|-----------|
| 5    | Z220225 | K.M  | 2022/03/09 | Y.H  | ANGLE               | ±2°      | 6 OVER 30 MAX.   | ±0.3     | PROJECTION<br>⊕                          | SERIES No.<br>R0           | CUSTOMER COPY |           |
| 4    | Z190626 | K.I  | 2019/05/09 | Y.H  | 6 MAX.              | ±0.2     | 30 OVER 120 MAX. | ±0.5     |  |                            |               |           |
| 3    | Z190256 | Yufu | 2019/02/28 | Y.H  | GENERAL TOLERANCE.  |          |                  |          | TITLE<br>MHF® -SW23<br>SMA ADAPTER CABLE | SCALE<br>3:1<br>UNIT<br>mm | I-PEX         |           |
| 2    | Z140966 | S.H  | 2014/08/14 | Tom  | DWG.                | DATE     |                  |          |  |                            |               |           |
| 1    | Z121013 | H.K  | 2012/11/22 | Tom  | H.Kon               |          | 2012/11/12       |          |  |                            |               |           |
| 0    | Z12981  | H.K  | 2012/11/12 |      | CHK.<br>K.Yotsutani |          |                  |          |  |                            |               |           |
| REV. | ECN     | BY   | DATE       | APP. | APP.                | T.Takano |                  | DWG. No. | 90582                                    | SIZE<br>A3                 | SHEET<br>1/2  | REV.<br>5 |

Confidential C

I-PEX Inc.

QKE-DFE06-02 REV.12

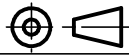
| ITEMS                           | SPECIFICATION  |
|---------------------------------|--|
| APPLICABLE CONNECTOR PART No.   | 20549-001E-**  |
| RATING FREQUENCY                | DC~11GHz   |
| OPERATING TEMPERATURE           | 233~343K(-40°C~+70°C)  |
| VSWR                            | 1.4 MAX. (DC~3GHz), 1.8 MAX. (3GHz~6GHz), 2.2 MAX. (6GHz~11Hz) |
| DIELECTRIC WITHSTANDING VOLTAGE | AC100V 1min  |
| DURABILITY                      | 1,000 CYCLES   |
| PRODUCT SPECIFICATION           | PRS-1759   |
| TEST REPORT                     | TR-12131   |
| INSTRUCTION MANUAL              | HIM-13004  |
| APPEARANCE CRITERIA No.         | QLS-A***   |

|                    |      |                  |      |   |                  |   |       |      |
|--------------------|------|------------------|------|---|------------------|---|-------|------|
| ANGLE              | ±2°  | 6 OVER 30 MAX.   | ±0.3 | PROJECTION<br> | SERIES No.<br>R0 | CUSTOMER COPY   |       |      |
| 6 MAX.             | ±0.2 | 30 OVER 120 MAX. | ±0.5 |   |                  |   |       |      |
| GENERAL TOLERANCE. |      |                  |      | TITLE<br>MHF® -SW23<br>SMA ADAPTER CABLE  | SCALE            |  |       |      |
| DWG.               | DATE |                  |      |   |                  |   |       |      |
| CHK.               |      |                  |      |   |                  |   |       |      |
| APP.               |      |                  |      |   |                  |   |       |      |
|                    |      |                  |      | DWG. No.  | 90582            | SIZE  | SHEET | REV. |
|                    |      |                  |      |   |                  | A3  | 2/2   | 5    |