

Recommended P/N 20347-3**E-12R

PART NO.	POS.	A	B	C	T
20347-310E-12R	10	8.40	3.60	8.80	2.60
20347-315E-12R	15	10.40	5.60	10.80	4.60
20347-320E-12R	20	12.40	7.60	12.80	6.60
20347-325E-12R	25	14.40	9.60	14.80	8.60
20347-330E-12R	30	16.40	11.60	16.80	10.60
20347-335E-12R	35	18.40	13.60	18.80	12.60
20347-340E-12R	40	20.40	15.60	20.80	14.60



Halogen Free



RoHS Compliant

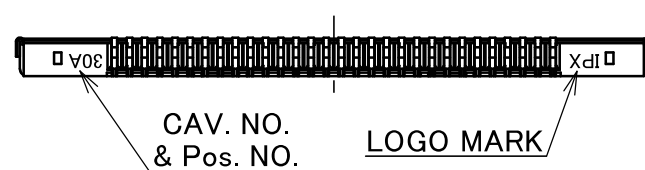
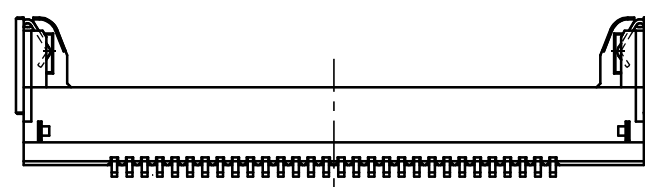
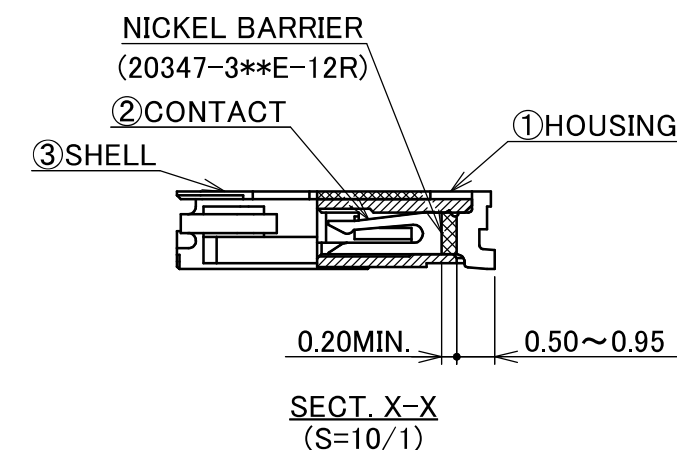
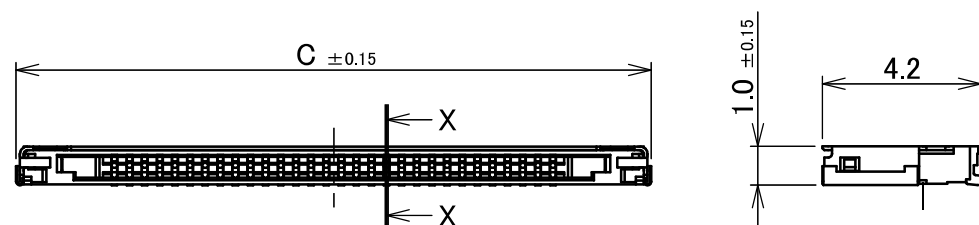
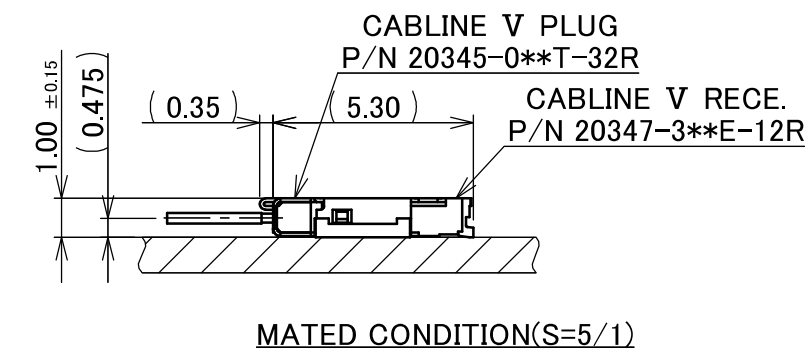
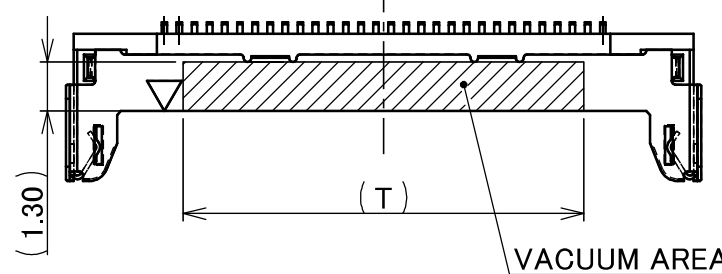
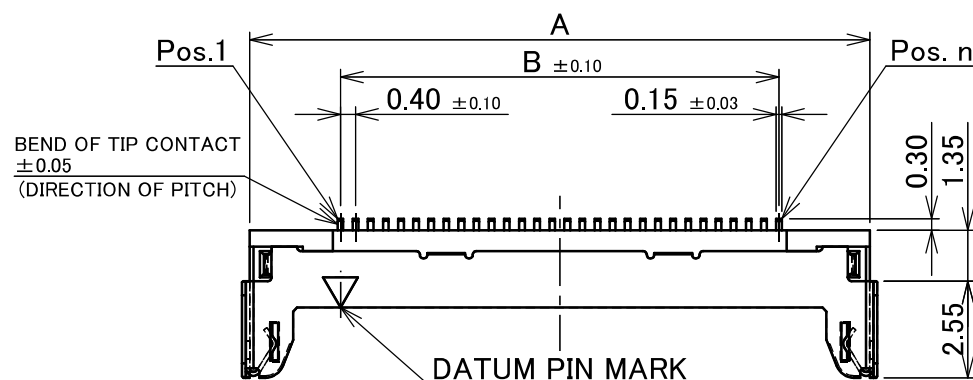

NO.	DISCRIPTION	MATERIAL	FINISH , REMARKS
3	SHELL	PHOSPHOR BRONZE	Sn 1.00 μ m MIN. OVER Ni 1.00 μ m MIN.
2	CONTACT	PHOSPHOR BRONZE	ALL OVER: Ni 1.00 μ m MIN. UNDER PLATING CONTACT AREA: Au 0.10 μ m MIN. SOLDERING AREA: Au 0.03 μ m MIN.
1	HOUSING	LCP	UL94V-0, BRACK

NO.	ECN	BY	DATE	APP.	APP.	DATE	PROJECTION	SERIES No.	TITLE	SCALE	CUSTOMER COPY		
37	Z250427	RYO	2025/03/13	H.I	ANGLE	±2°	6 OVER 30 MAX.	±0.3		R12	CUSTOMER COPY		
36	Z240028	RYO	2024/01/10	H.I	6 MAX.	±0.2	30 OVER 120 MAX.	±0.5					
35	Z230596	R.H	2023/05/24	H.I	GENERAL TOLERANCE.				CABLINE® V RECEPTACLE ASSEMBLY	5:1	I-PEX		
34	Z210585	A.K	2021/06/07	H.I	DWG.	H.Mashima	DATE					2003/03/07	mm
33	Z200103	A.K	2020/01/23	H.I	CHK.	Y.H	2003/03/12						
32	Z181347	K.H	2018/10/15	H.I	APP.	K.Katabuchi	2003/03/13						
REV.	ECN	BY	DATE	APP.	APP.	DATE	DWG. No.	20347	SIZE	SHEET	REV.		
REVISION RECORD							K.Katabuchi	2003/03/13	A3	1/5	37		

ITEMS	SPECIFICATION
APPLICABLE CABLE	MICRO-COAXIAL CABLE : AWG# 44,42,40 DISCRETE WIRE : AWG# 36 TWINAX : AWG# 40
RATING VOLTAGE	100V AC (PER CONTACT PIN)
RATING AMPERAGE (FOR CONTACT)	0.1A AC/DC [AWG#44] PER CONTACT PIN / UP TO 40 CONTACTS 0.24A AC/DC [AWG#42] PER CONTACT PIN / UP TO 40 CONTACTS 0.3A AC/DC [AWG#40] PER CONTACT PIN / UP TO 40 CONTACTS 0.8A AC/DC [AWG#36] PER CONTACT PIN / UP TO 12 CONTACTS ※TESTING BY A REAL MACHINE IS RECOMMENDED BECAUSE TEMPERATURE RISE MAY AFFECTED BY ACTUAL SITUATION.
OPERATING TEMPERATURE	233~358K(-40°C~+85°C)
OPERATING HUMIDITY	85% MAX.(NON-CONDENSING)
CONTACT RESISTANCE	INITIAL : 235mohm MAX.(AWG#36) / AFTER TEST : \triangle 40mohm MAX. 560mohm MAX.(AWG#40) 650mohm MAX.(AWG#42) 1040mohm MAX.(AWG#44)
GROUND SHELL RESISTANCE	INITIAL : 50mohm MAX. / AFTER TEST : \triangle 40mohm MAX.
INSULATION RESISTANCE	INITIAL : 1000Mohm MIN. / AFTER TEST : 500Mohm MIN.
DIELECTRIC WITHSTANDING VOLTAGE	AC250V 1min
DURABILITY	30 CYCLES
MATING FORCE (INITIAL / AFTER TEST)	10P : 20.0N MAX. 15P : 22.5N MAX. 20P : 25.0N MAX. 25P : 27.5N MAX. 30P : 30.0N MAX. 35P : 32.5N MAX. 40P : 35.0N MAX.
UNMATING FORCE (INITIAL / AFTER TEST)	10P : 4.0N MIN. 15P : 5.0N MIN. 20P : 5.5N MIN. 25P : 6.0N MIN. 30P : 7.0N MIN. 35P : 8.0N MIN. 40P : 8.5N MIN.
CABLE RETENTION FORCE	10P : 4.90N MIN. 15P : 7.35N MIN. 20P : 9.80N MIN. 25P : 12.25N MIN. 30P : 14.70N MIN. 35P : 17.15N MIN. 40P : 19.60N MIN.
COPLANARITY	0.10 MAX.
PRODUCT SPECIFICATION	P/N 20347-3**E-12R : PRS-1461
TEST REPORT	P/N 20347-3**E-12R : TR-08068
PACKING STANDARD	300-308
INSTRUCTION MANUAL	HIM-03005
ASSEMBLY MANUAL	ASM-03002
APPEARANCE CRITERIA NO.	QLS-A***

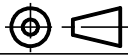
ANGLE	$\pm 2^\circ$	6 OVER 30 MAX.	± 0.3	PROJECTION 	SERIES No. R12	CUSTOMER COPY		
		6 MAX.	± 0.2					
GENERAL TOLERANCE.				TITLE CABLIN [®] V RECEPTACLE ASSEMBLY	SCALE 5:1 UNIT mm	I-PEX		
DWG.	DATE							
CHK.								
APP.								
				DWG. No.	20347	SIZE A3	SHEET 2/5	REV. 37

PART NO.	POS.	B	D	E	F
20347-310E-12R	10	3.60	8.10	9.94	8.97
20347-315E-12R	15	5.60	10.10	10.94	10.97
20347-320E-12R	20	7.60	12.10	12.94	12.97
20347-325E-12R	25	9.60	14.10	14.94	14.97
20347-330E-12R	30	11.60	16.10	16.94	16.97
20347-335E-12R	35	13.60	18.10	18.94	18.97
20347-340E-12R	40	15.60	20.10	20.94	20.97

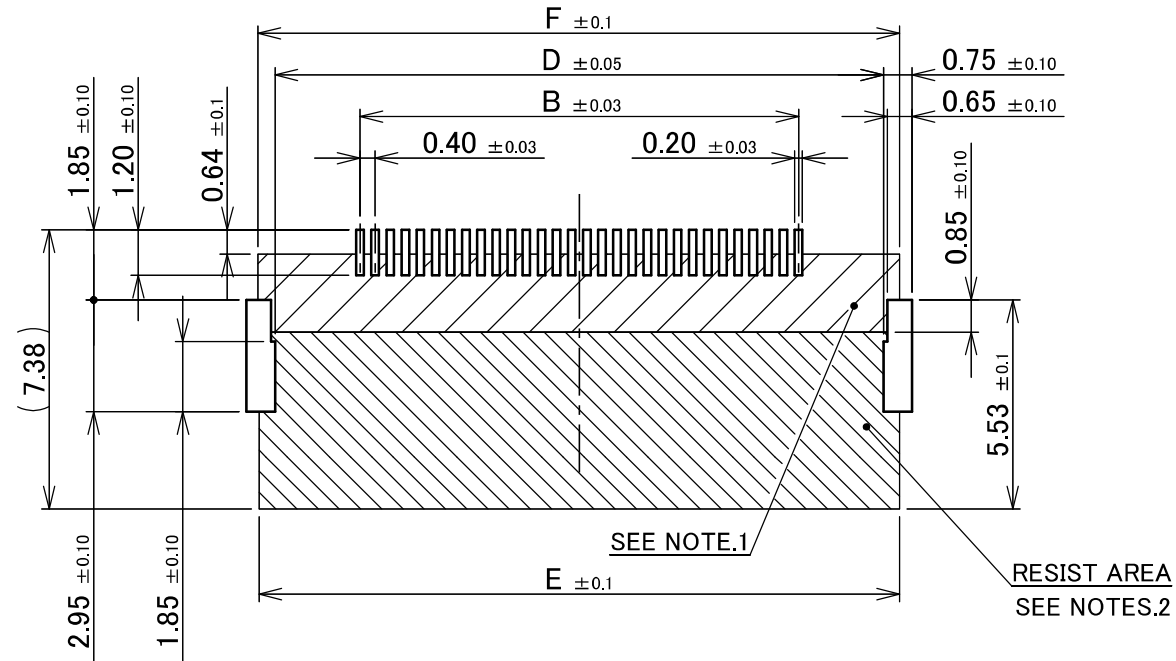

RECOMMENDED FOOT PRINT PATTERN & METALMASK LAYOUT
 RECOMMENDED METALMASK THICKNESS : t=0.12

NOTES.

- DO NOT MOUNT ANOTHER COMPONENTS IN THIS AREA.
- SOLDER RESIST MUST BE APPLIED TO THIS AREA.

ANGLE	±2°	6 OVER 30 MAX.	±0.3	PROJECTION 	SERIES No. R12	CUSTOMER COPY		
	6 MAX.	±0.2	30 OVER 120 MAX.					
GENERAL TOLERANCE.				TITLE CABLIN [®] V RECEPTACLE ASSEMBLY	SCALE 5:1 UNIT mm			
DWG.	DATE							
CHK.								
APP.								
				DWG. No.	20347	SIZE	SHEET	REV.
						A3	3/5	37

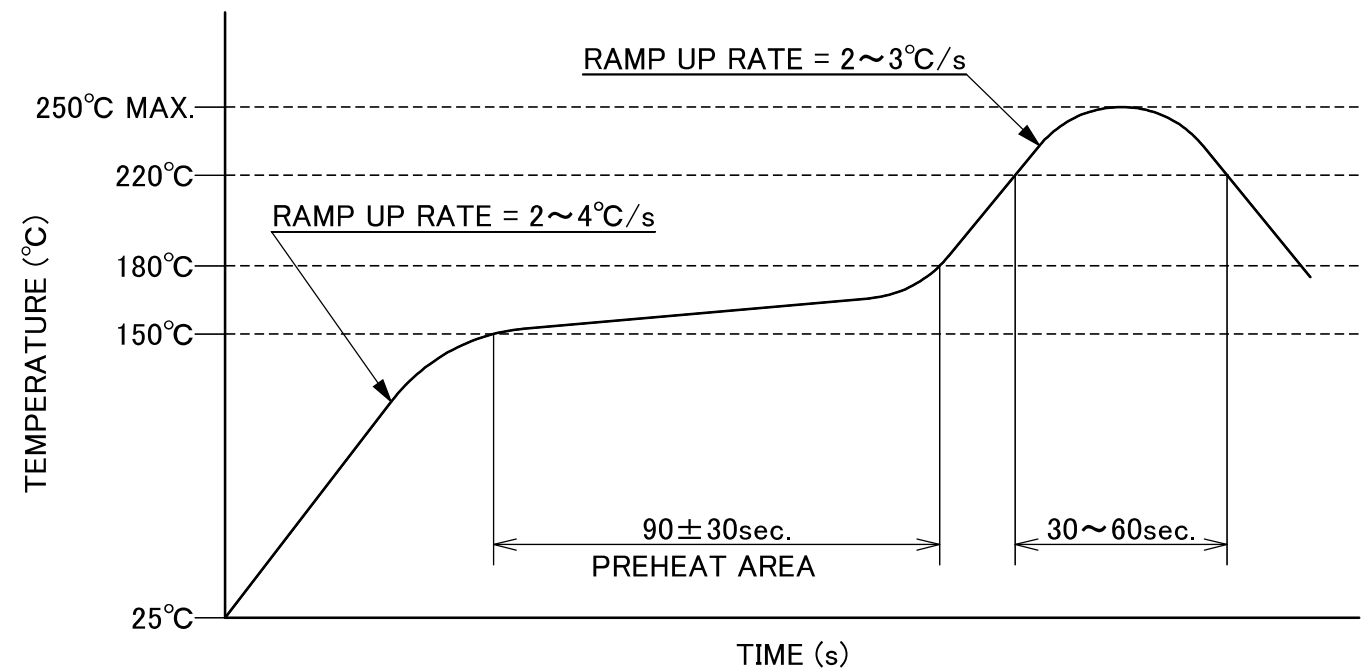
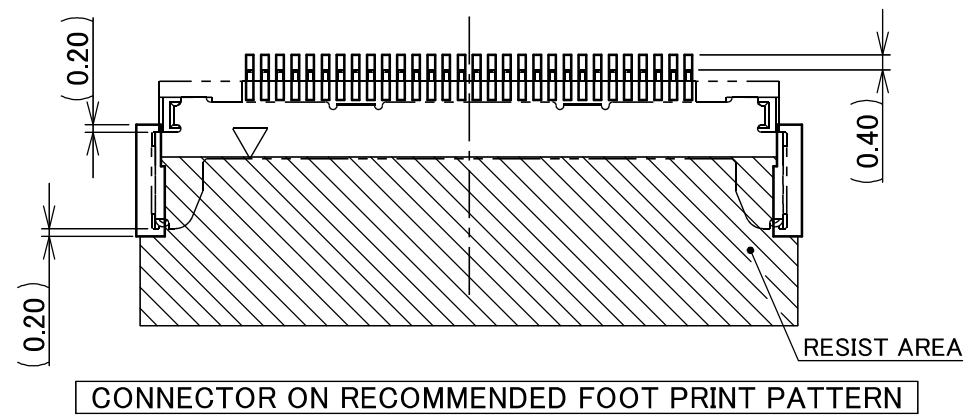

REFLOW TEMPERATURE PROFILE
 SENJU METAL INDUSTRY CO., LTD. : M705-SHF(Sn96.5 Ag3.0 Cu0.5)

ANGLE	±2°	6 OVER 30 MAX.	±0.3	PROJECTION 	SERIES No. R12	CUSTOMER COPY		
6 MAX.	±0.2	30 OVER 120 MAX.	±0.5					
GENERAL TOLERANCE.				TITLE CABLIN [®] V RECEPTACLE ASSEMBLY	SCALE 5:1 UNIT mm			
DWG.	DATE							
CHK.								
APP.								
				DWG. No.	20347	SIZE A3	SHEET 4/5	REV. 37

PART NO.	J	K	L	M	N	P	Q	R	S	QTY. PER EMBOSS REEL (PIECES / REEL)	QTY. PER PACKING CARTON (REELS / CARTON)	TOP TAPE TYPE
20347-310E-12R	16.0	7.5	-	9.2	7.5	4.5	3.0	5.0	13.5	2000 PIECES / REEL	7 REELS / CARTON =14000	HEAT SEALING TYPE
20347-315E-12R	24.0	11.5	-	11.2	9.5	6.5	5.0	7.0	21.5		5 REELS / CARTON =10000	
20347-325E-12R	24.0	11.5	-	15.2	13.5	10.5	9.0	11.0	21.5			
20347-330E-12R	24.0	11.5	-	17.2	15.5	12.5	11.0	13.0	21.5			
20347-335E-12R	32.0	14.2	28.4	19.2	17.5	14.5	13.0	15.0	26.0		4 REELS / CARTON = 8000	
20347-340E-12R	32.0	14.2	28.4	21.2	19.5	16.5	15.0	17.0	26.0			

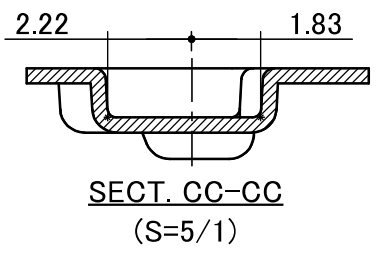
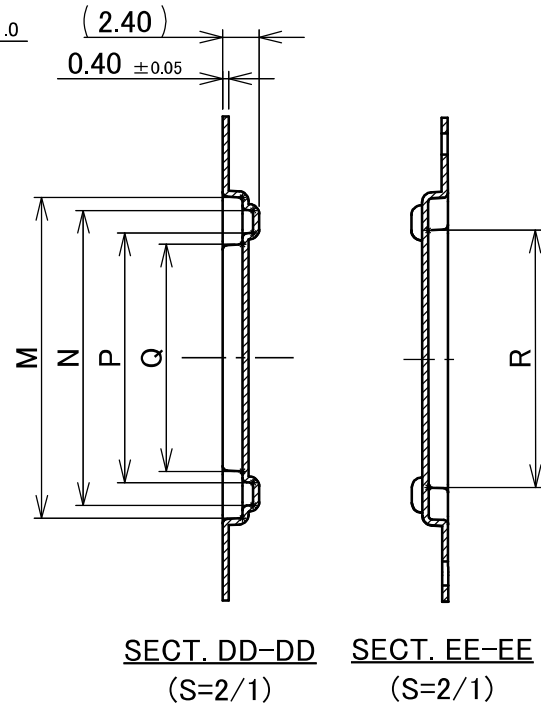
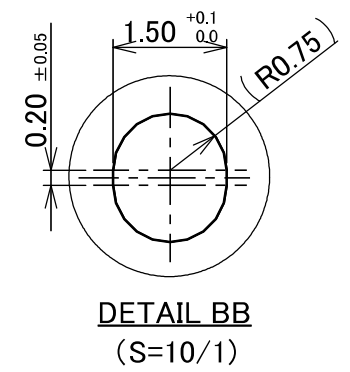
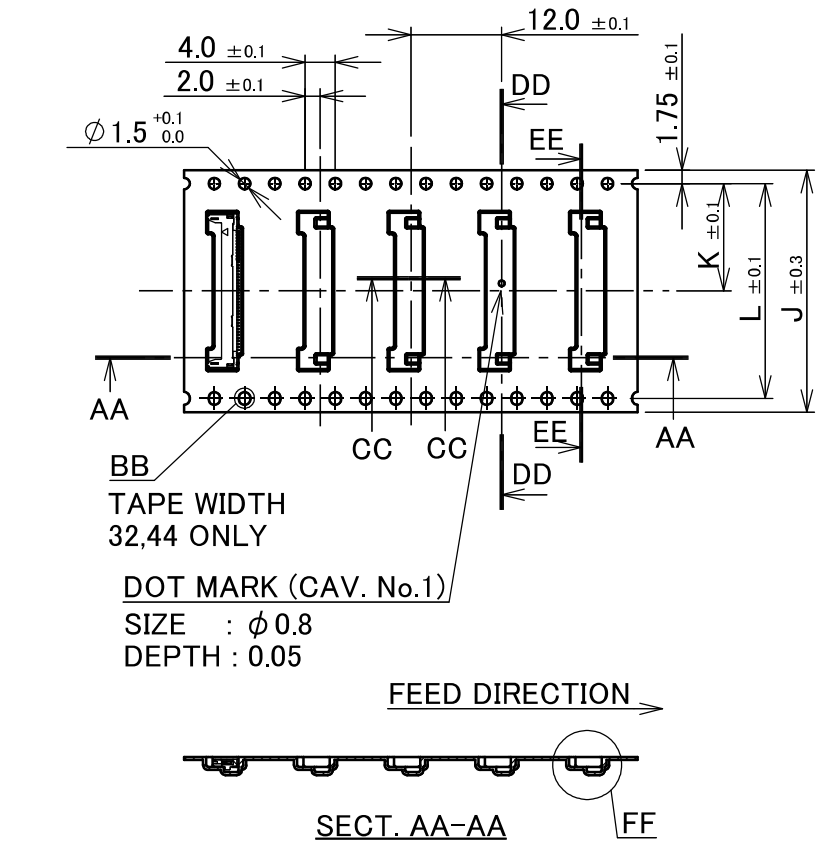
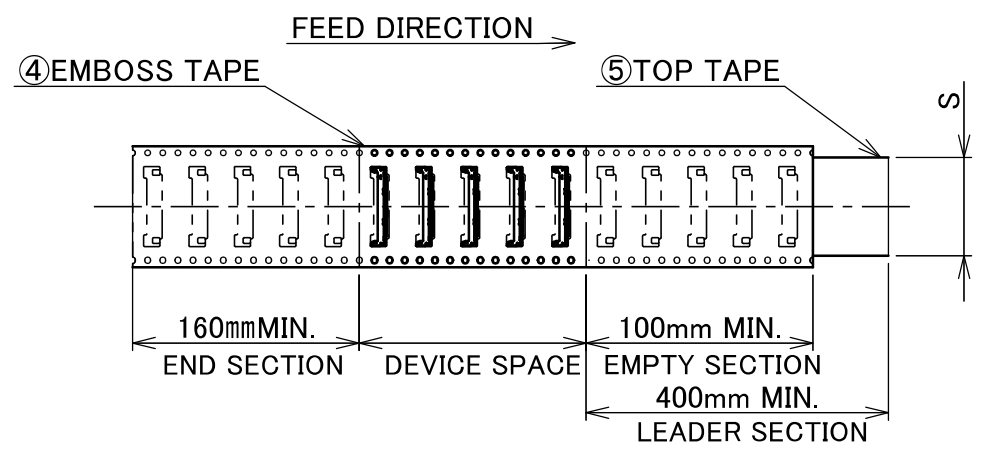
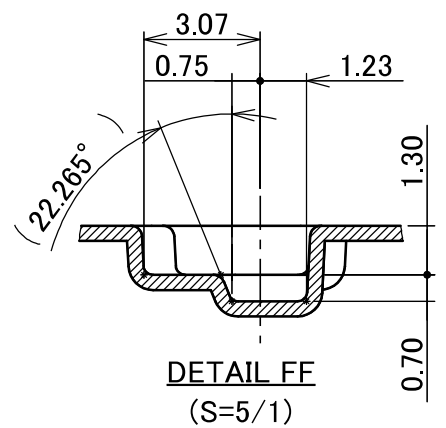
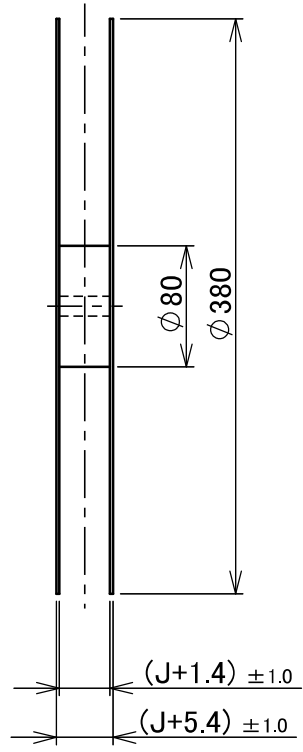
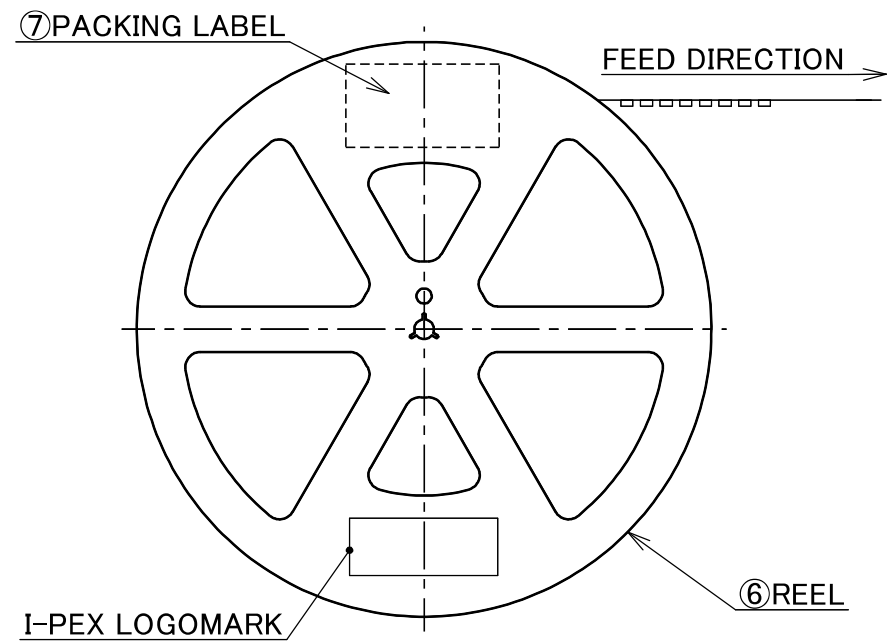

- NOTES.
- TAPING SPECIFICATION FOLLOWS JIS C 0806 (IEC 60286-3).
 - MAKE EMPTY SECTION OF LEADER AND END ON EACH END OF THE TAPE.
 - TOP TAPE SHALL NOT STICK OUT FROM EMBOSS TAPE.
 - TOP TAPE SHALL NOT COVER FEED HOLE.

NO.	DISCRIPTION	MATERIAL	FINISH , REMARKS
7	PACKING LABEL	-	-
6	REEL	PS	-
5	TOP TAPE	PET t=0.062 TRANSPARENCY	NON ANTISTATIC TYPE
4	EMBOSS TAPE	PS t=0.3 TRANSPARENCY	NON ANTISTATIC TYPE

ANGLE	$\pm 2^\circ$	6 OVER 30 MAX.	± 0.3	PROJECTION 	SERIES No. R12	CUSTOMER COPY		
6 MAX.	± 0.2	30 OVER 120 MAX.	± 0.5					
GENERAL TOLERANCE.				TITLE CABLIN [®] V RECEPTACLE ASSEMBLY	SCALE 5:1	I-PEX		
DWG.	DATE							
CHK.								
APP.								
DWG. No. 20347				SIZE A3	SHEET 5/5	REV. 37		