

PART NO.	STRUCTURE
91575-0**B-001	MAIN BOARD A ASSMBLY: 1PC. MAIN BOARD B ASSMBLY: 1PC. 2xTHRU BOARD ASSMBLY: 1PC.

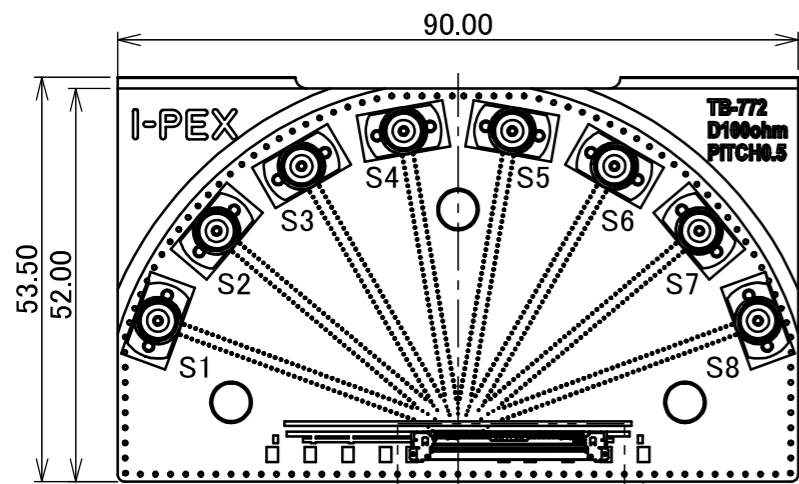

MAIN BOARD A

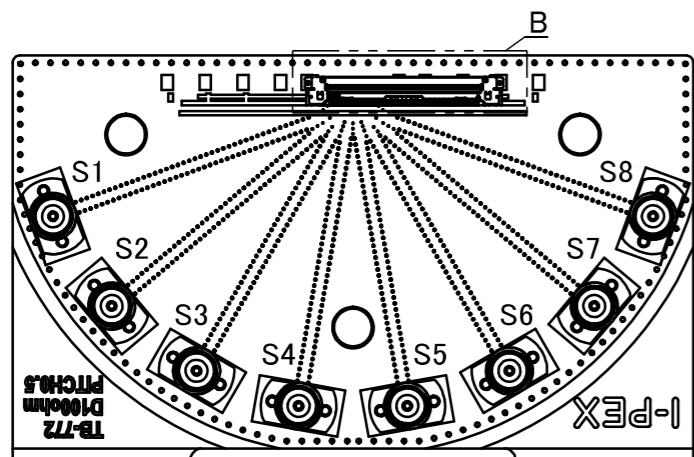

MAIN BOARD B

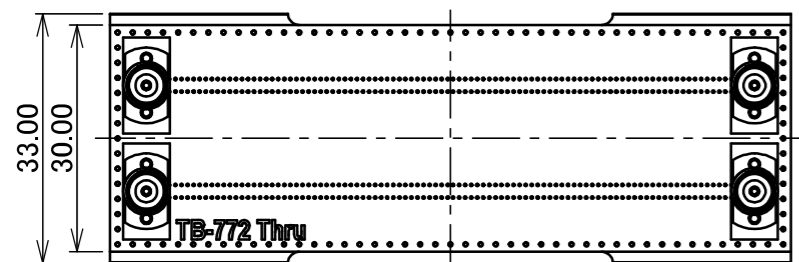

2xTHRU BOARD

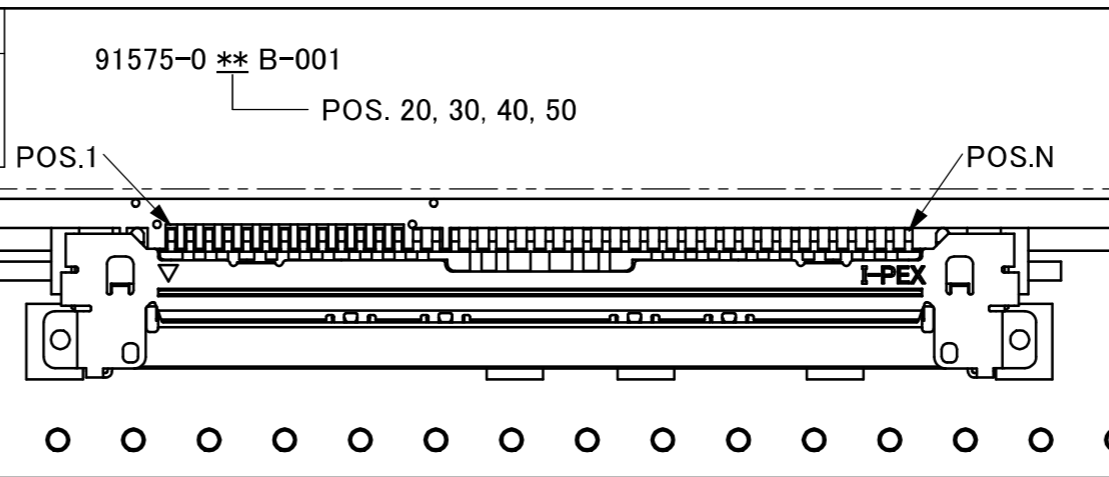

DETAIL A
(S= 5 : 1)

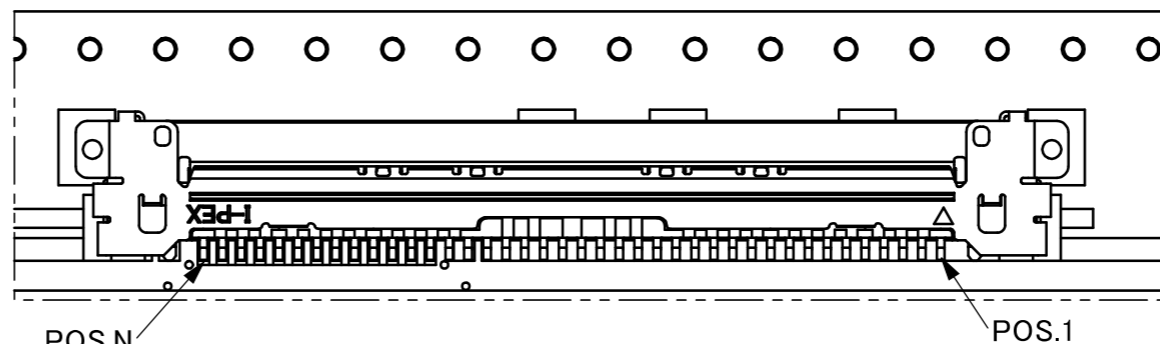

DETAIL B
(S= 5 : 1)

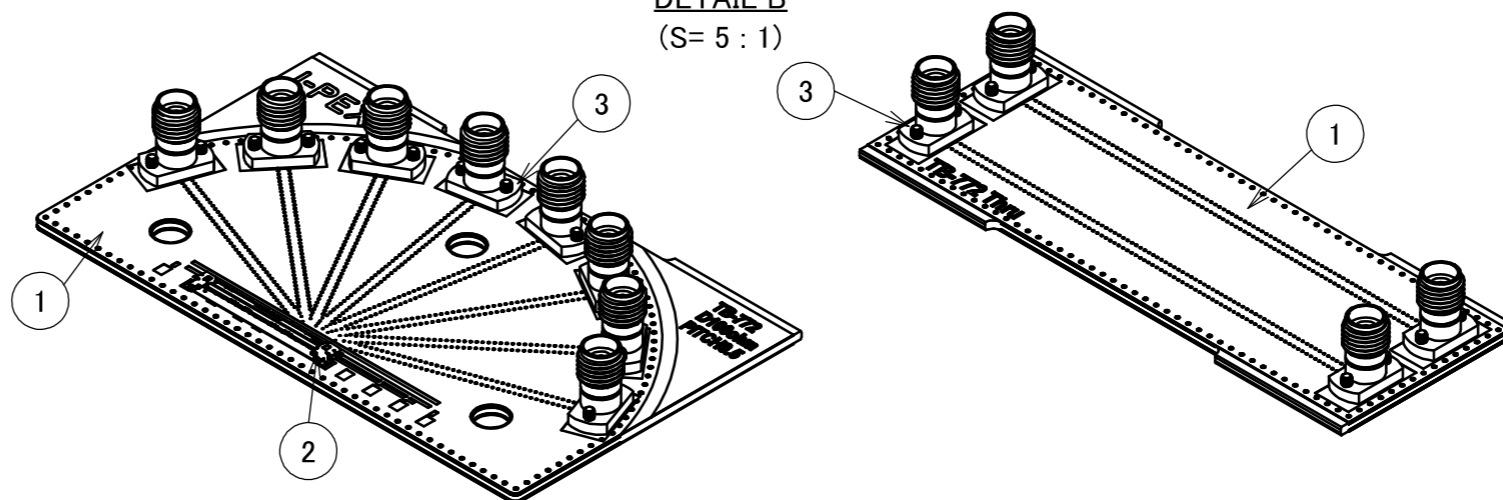

MAIN BOARD A/B ASSEMBLY

2xTHRU BOARD ASSEMBLY

MAIN BOARD A	
PIN POS.	ASSIGNMENT
1	GND
2	S1
3	S2
4	GND
5	S3
6	S4
7	GND
8	S5
9	S6
10	GND
11	S7
12	S8
13	GND

MAIN BOARD B	
PIN POS.	ASSIGNMENT
N	GND
N-1	S1
N-2	S2
N-3	GND
N-4	S3
N-5	S4
N-6	GND
N-7	S5
N-8	S6
N-9	GND
N-10	S7
N-11	S8
N-12	GND

NO.	DESCRIPTION	PART NO.	QTY	REMARKS
3	2.92mm CONNECTOR	50104-J001	20	JACK
2	CONNECTOR	20455-***E-76	2	CABLINÉ-VS RECEPTACLE
1	TEST BOARD	TB-772	1	TEST BOARD THICKNESS: 1.60mm

NOTES.

- FOR DETAILED INFORMATION ON THE STRUCTURE OF TEST BOARD TB-772, REFER TO REPORT #IER-001-10705.
- CHARACTERISTIC IMPEDANCE: $50 \Omega \pm 10\%$ (SINGLE-ENDED), $T_r=17.5$ ps (10% - 90%)
- APPLICABLE PLUG CONNECTOR: CABLINE-VS PLUG (P/N: 20453-***T-###)
- MAXIMUM MEASUREMENT FREQUENCY: 40 GHz
- OTHER PIN CONFIGURATIONS CAN BE PROVIDED UPON REQUEST.

ANGLE	$\pm 2^\circ$	6 OVER 30 MAX.	± 0.3	PROJECTION 	SERIES No. R2R8R0	CUSTOMER COPY			
	6 MAX.	± 0.2	30 OVER 120 MAX.				± 0.5		
GENERAL TOLERANCE.				TITLE CABLINÉ® -VS SI TEST BOARD ASSEMBLY	SCALE 1:1	UNIT mm			
DWG.	T.Ono	DATE	2024/08/28						
CHK.	M.Nakamura	APP.	T.Masunaga						
0	Z241084	T.Ono	2024/08/28	T.M	DWG. No.	91575	SIZE A3	SHEET 1/2	REV. 0
REVISION RECORD									

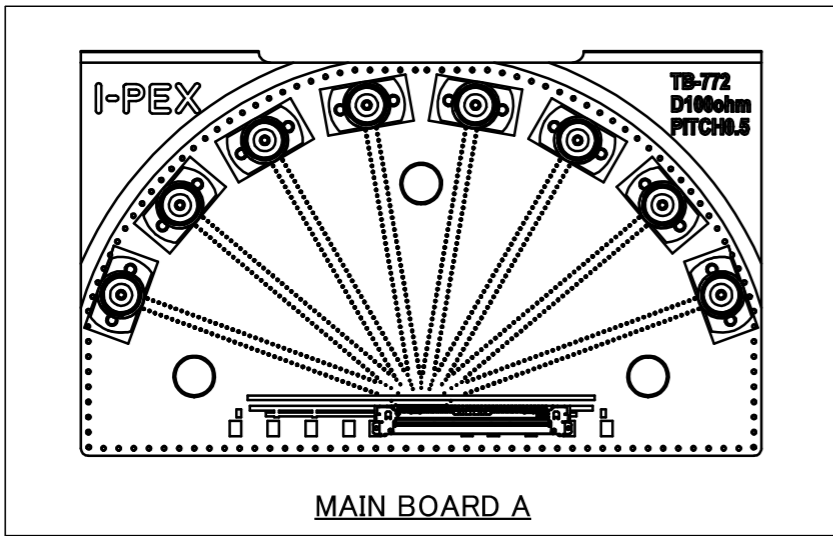

<SMALL BAG>
REUSABLE PLASTIC BAG

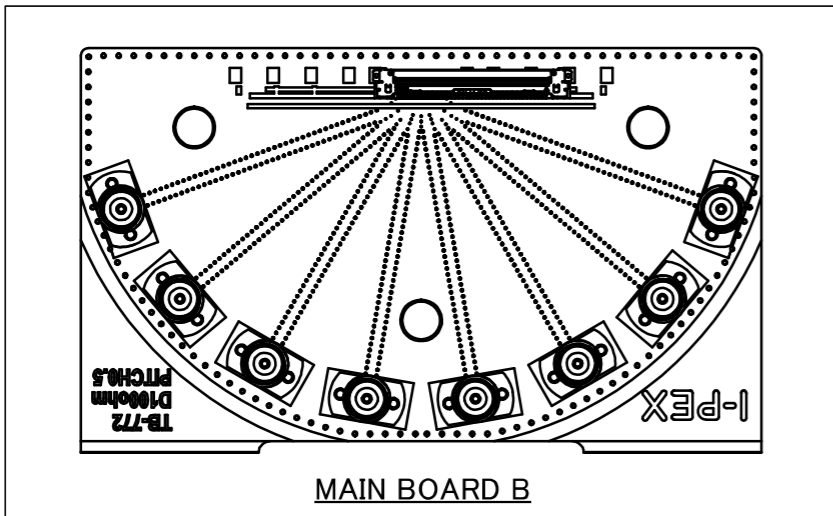

<SMALL BAG>
REUSABLE PLASTIC BAG

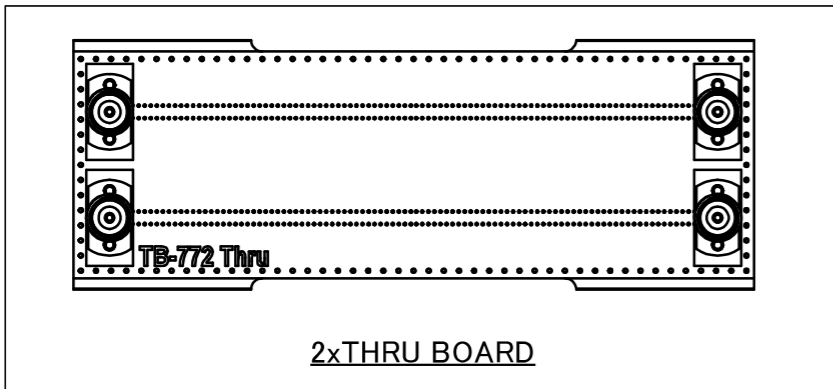

<SMALL BAG>
REUSABLE PLASTIC BAG

<LARGE BAG>
REUSABLE PLASTIC BAG

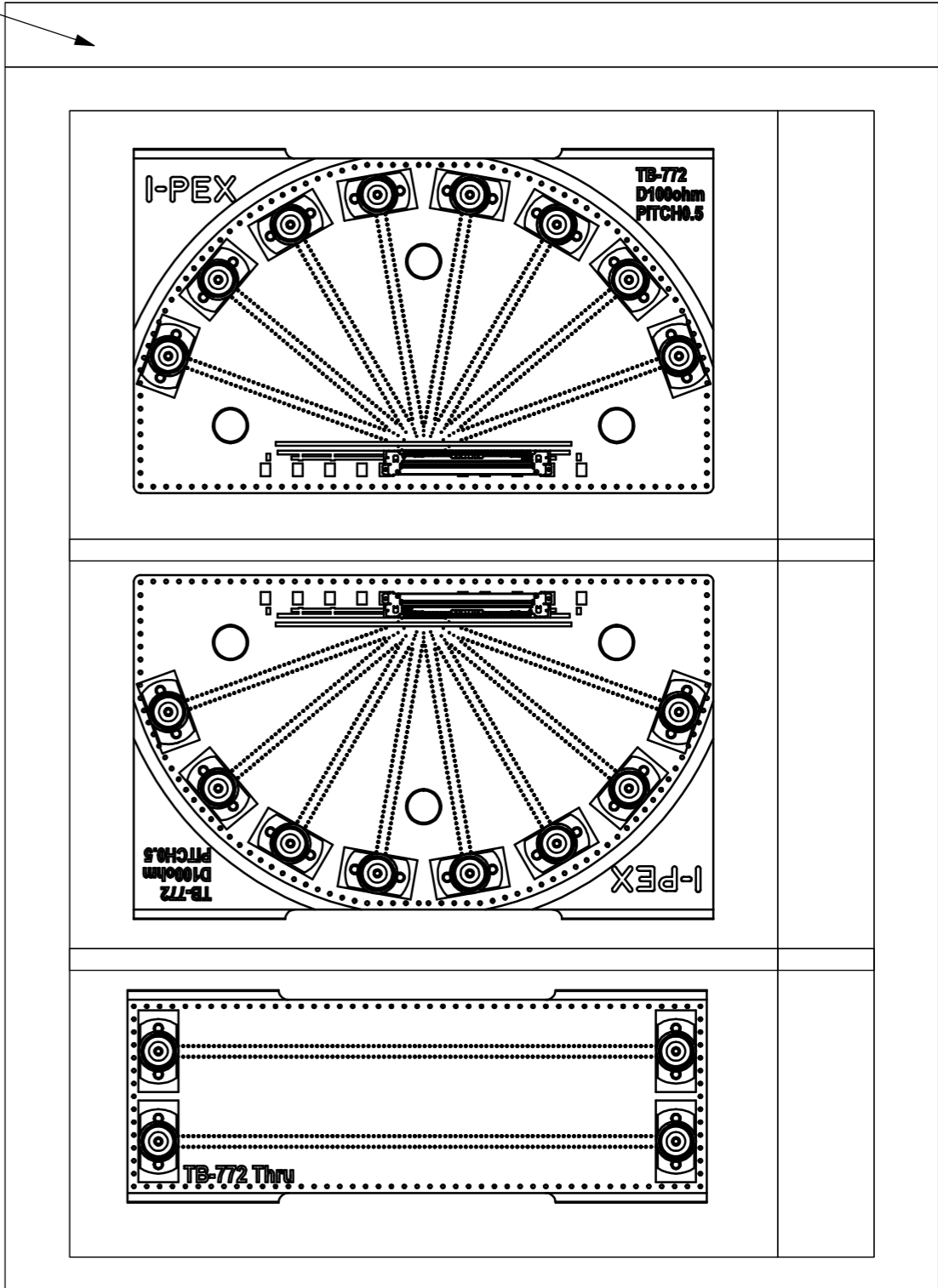

PACKING STYLE

ANGLE	±2°	6 OVER 30 MAX.	±0.3	PROJECTION ⊕	SERIES No. R2R8R0	CUSTOMER COPY			
6 MAX.	±0.2	30 OVER 120 MAX.	±0.5			SCALE 1:1	I-PEX		
GENERAL TOLERANCE.				TITLE CABLIN [®] -VS SI TEST BOARD ASSEMBLY	UNIT mm	SIZE A3			
DWG.	DATE				DWG. No.		91575		
CHK.									
APP.									