

Recommended P/N 2576-1\*\*-00

PART NO.	Pos.	A	B
2576-#20-00	20	15.05	16.45
2576-#30-00	30	20.05	21.45
2576-#40-00	40	25.05	26.45
2576-#50-00	50	30.05	31.45

2576-0\*\*-00



Halogen Free



RoHS Compliant

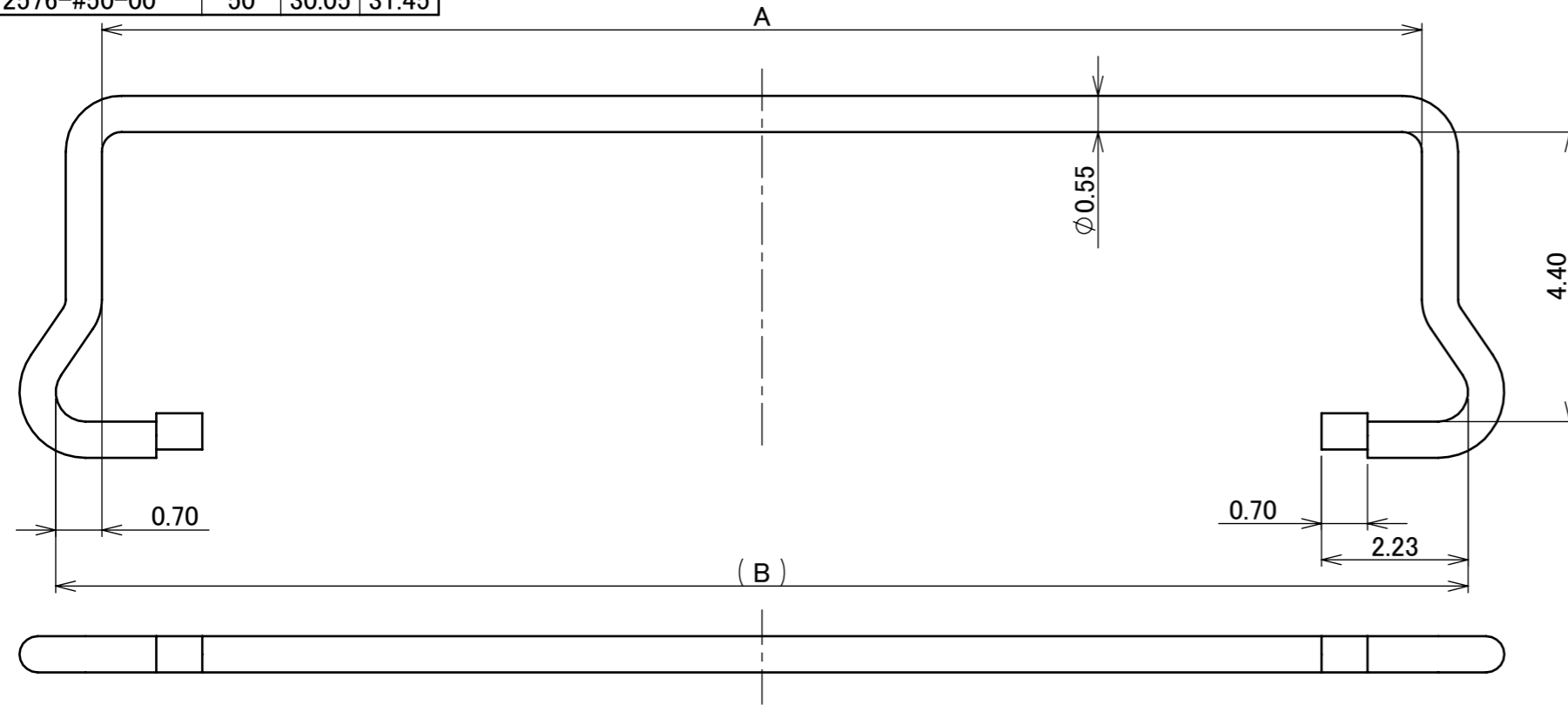

P/N: 2576-#\*\*-00

POS.

0 : WITHOUT INSULATION COAT  
1 : WITH INSULATION COAT

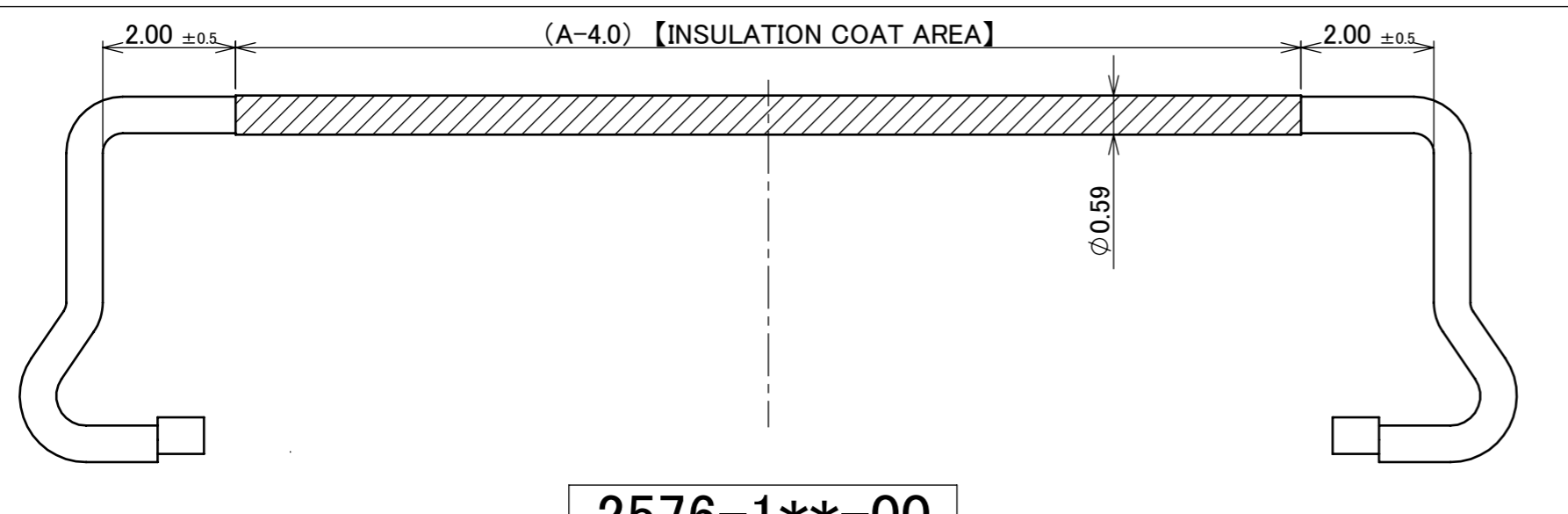

2576-1\*\*-00

NO.	DISCRIPTION	MATERIAL	FINISH , REMARKS
1	PULL BAR	SUS	-

REV.	ECN	BY	DATE	APP.	APP.	DATE	CHK.	APP.	DATE	PROJECTION	SERIES No.	TITLE	SCALE	SHEET	REV.	
15	Z221440	T.Ono	Dec./20/'22	H.I	ANGLE	±2°	6 OVER 30 MAX.	±0.3			R0	CABLINÉ® -VS PLUG PULL BAR	10:1	1/2	15	
14	Z210546	R.M	May/26/'21	H.I	6 MAX.	±0.2	30 OVER 120 MAX.	±0.5	UNIT							
13	Z191177	R.M	Sept./16/'19	H.I	GENERAL TOLERANCE.							mm	A3	1/2	15	
12	Z181003	Y.M	July/31/'18	H.I	DWG.	H.Ikari		DATE	2008/04/16							
11	Z180796	A.K	June/20/'18	H.I												
10	Z180048	Y.M	Jan./12/'18	H.I												
REVISION RECORD					E.Kawabe					DWG. No.	2576					

PART NO.	PACKING STATUS	C	STICK or PLASTIC BAG QTY.	QTY. (1 STICK or 1 PLASTIC BAG)	QTY. IN SHIPPING CARTON (1 CARTON)	QTY. IN PACKING CARTON (1 CARTON)	PACKING STANDARD
2576-020-00	PLASTICK BAG	-	5	1000	1000 × 5 = 5000	20000 (4 BOXES)	300-661
2576-030-00							
2576-040-00							
2576-050-00							
2576-120-00	STICK	24.0	10	500	500 × 10 = 5000	20000 (4 BOXES)	300-818
2576-130-00		29.0					
2576-140-00		34.0					
2576-150-00		39.0					

**PLACTIC BAG (2576-0\*\*-00)**

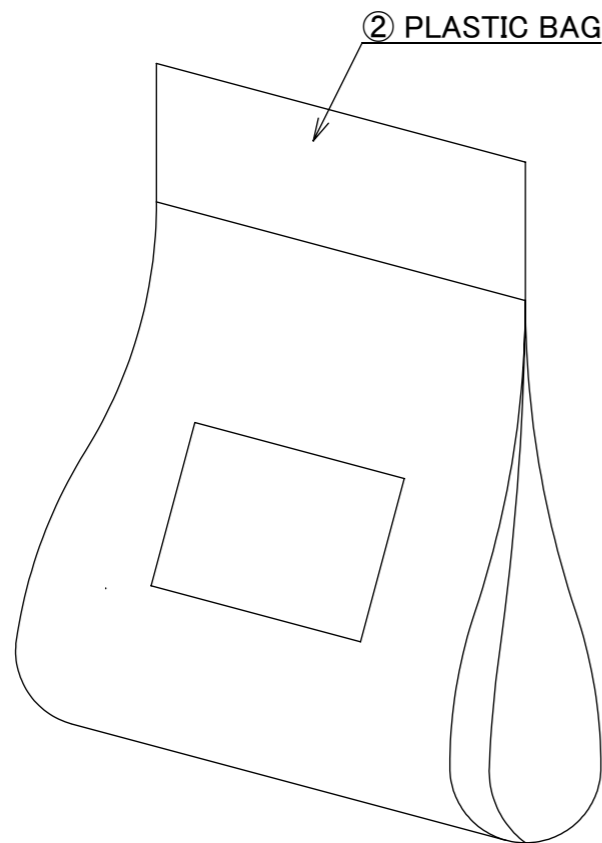

**STICK (2576-1\*\*-00)**

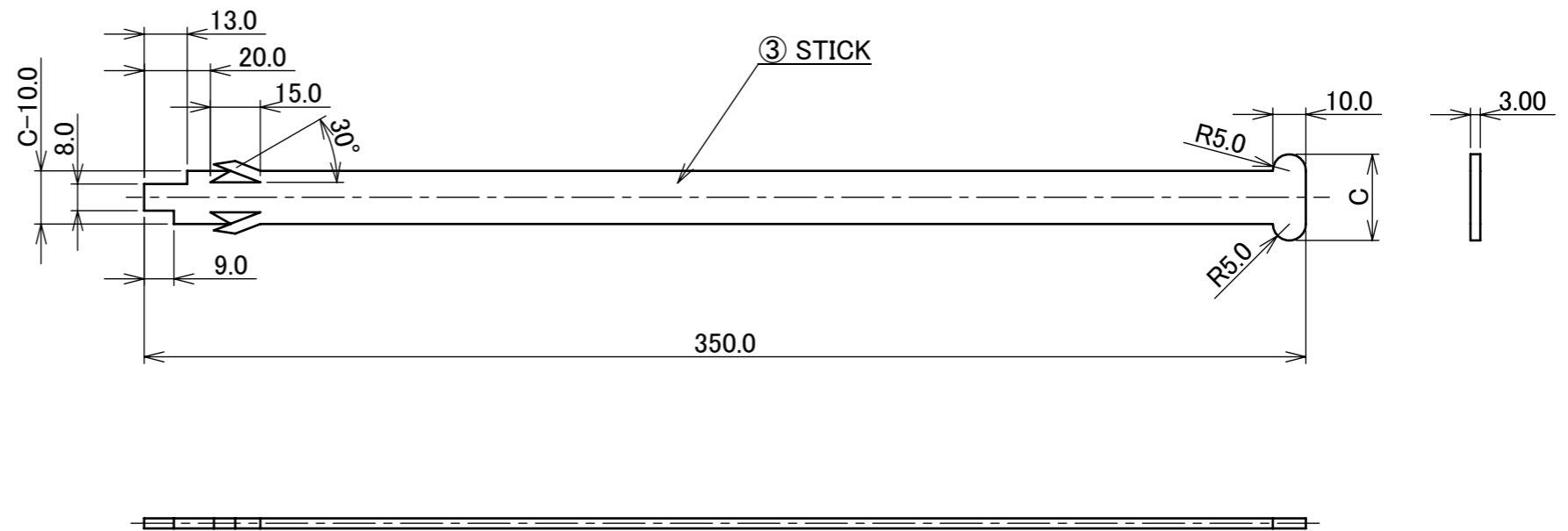

NO.	DISCRIPTION	MATERIAL	FINISH , REMARKS
3	STICK	PP	-
2	PLASTIC BAG	PE	-

ANGLE	±2°	6 OVER 30 MAX.	±0.3	PROJECTION ⊕	SERIES No. R0	CUSTOMER COPY		
6 MAX.	±0.2	30 OVER 120 MAX.	±0.5					
GENERAL TOLERANCE.				TITLE CABLINÉ® -VS PLUG PULL BAR		SCALE 1:2	<b>I-PEX</b>	
DWG.	DATE			DWG. No. 2576		UNIT mm		
CHK.						SIZE A3		