

Recommended P/N 20453-2**T-03(20P/30P/40P) 20453-250T-03S(50P)

PART NO.	Pos.	A	B	C	D	E	F	G	H
20453-#20T-#1	20	9.50	10.30	12.56	16.00	16.15	13.00	17.55	14.45
20453-#30T-#1	30	14.50	15.30	17.56	21.00	21.15	18.00	22.55	19.45
20453-#40T-#1	40	19.50	20.30	22.56	26.00	26.15	23.00	27.55	24.45
20453-#50T-#1S	50	24.50	25.30	27.56	31.00	31.15	28.00	32.55	29.45

WITH PULL-BAR & PULL-TAPE



P/N:20453-#**T-##
 NOTHING : HOUSING ASS'Y P/N 20454-##*T
 S : HOUSING ASS'Y P/N 20454-##*T-01
 1 : WITH PULL-BAR P/N 2576-0**-00
 2 : WITHOUT PULL-BAR
 3 : WITH INSULATION COAT PULL-BAR P/N 2576-1**-00
 0 : WITH DATUM MARK P/N 2574-0**#
 1 : WITHOUT DATUM MARK P/N 2574-1**#
 SEE TABLE.1

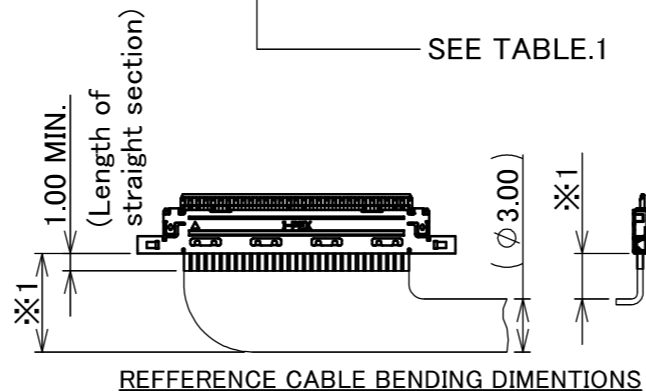
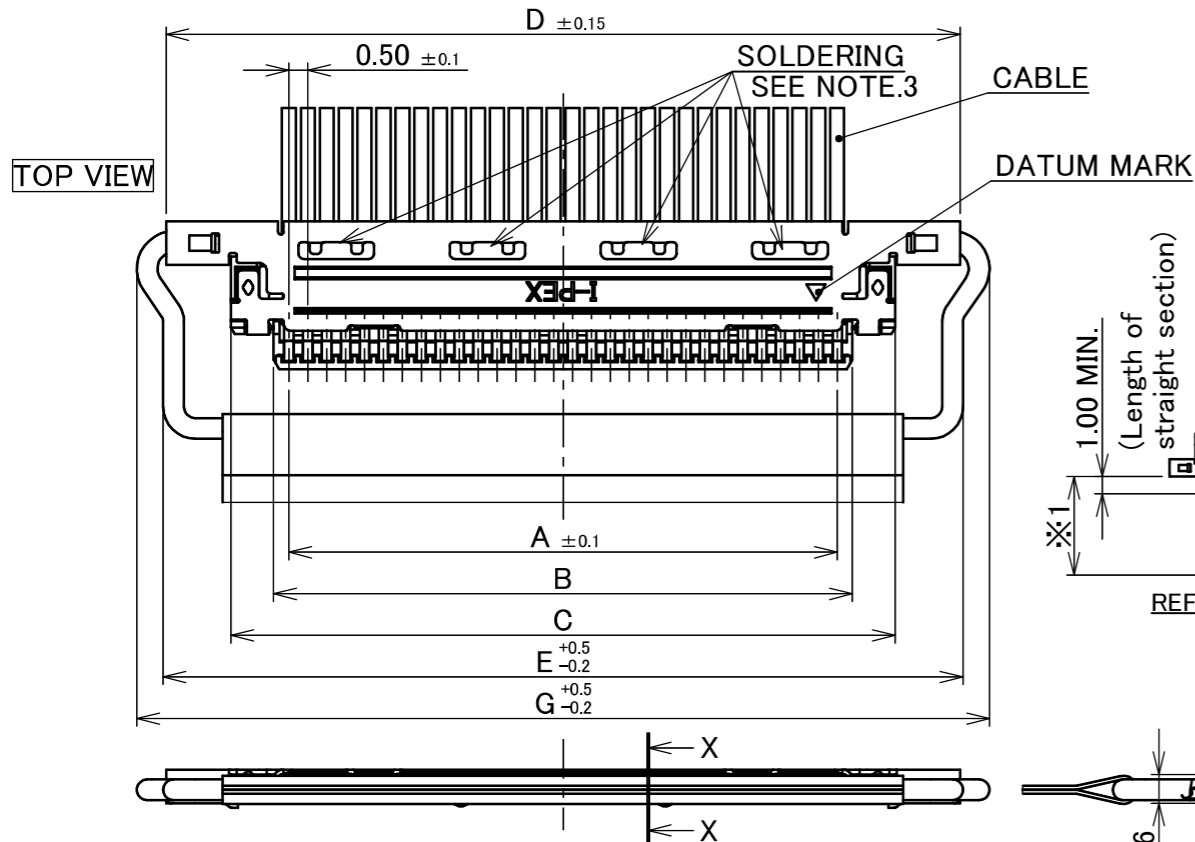
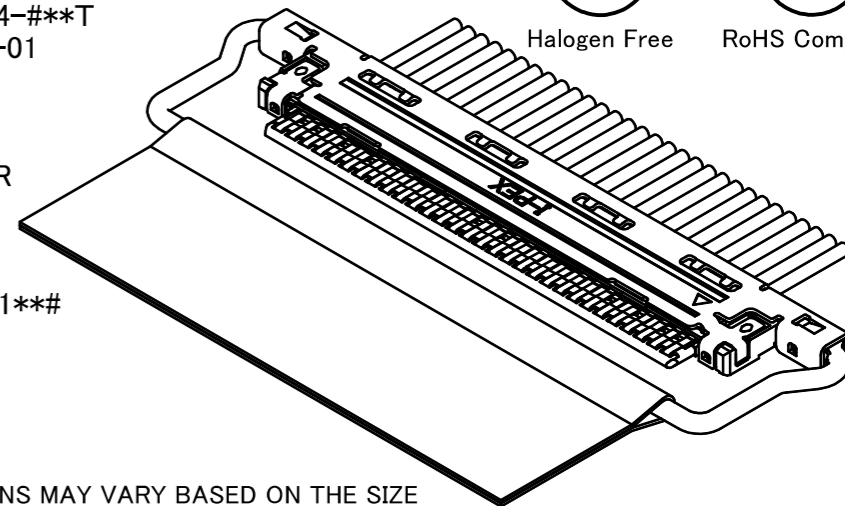

※1: THE BEND DIMENSIONS MAY VARY BASED ON THE SIZE AND QUANTITY OF CABLES. PLEASE CONFIRM THE MINIMUM BENDING RADIUS WITH I-PEX OR THE HARNESS MANUFACTURER.

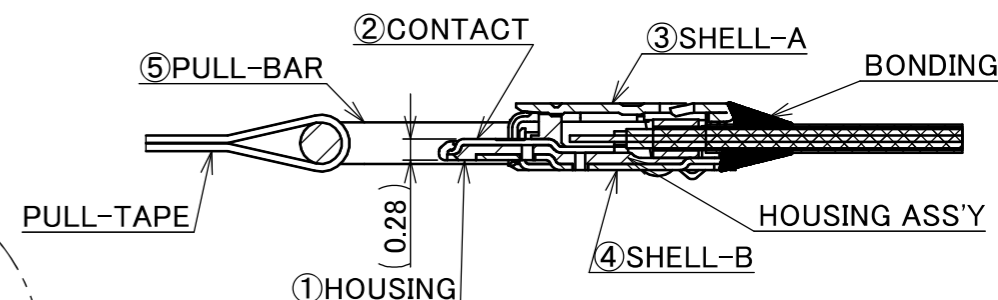

SECT X-X
S= 10 : 1

CABLE ASS'Y PART NO.	HOUSING ASS'Y PART NO.	SHELL-A PART NO.	PULL-BAR PART NO.
20453-0**T-#1#	20454-0**T-##	2574-##	2576-0**-00
20453-2**T-#1#	20454-2**T-##	2574-##2	2576-0**-00

TABLE.1

PART NO.	CONTACT FINISH	SHELL-A FINISH	SHELL-B FINISH
20453-0**T-##	CONTACT AREA : Au 0.1 μm MIN. OVER Ni 1.00 μm MIN. SOLDERING AREA : Au 0.05 μm MIN. OVER Ni 1.00 μm MIN.	TOP SIDE : Au 0.05 μm MIN. OVER Ni 1.00 μm MIN. BOTTOM SIDE : Au 0.015 μm MIN. OVER Ni 1.00 μm MIN.	TOP SIDE : Au 0.015 μm MIN. OVER Ni 1.00 μm MIN. BOTTOM SIDE : Au 0.05 μm MIN. OVER Ni 1.00 μm MIN.
20453-2**T-##	CONTACT AREA : Au 0.1 μm MIN. OVER Ni 1.00 μm MIN. SOLDERING AREA : Au 0.05 μm MIN. OVER Ni 1.00 μm MIN.	TOP SIDE : Au 0.03 μm MIN. OVER Ni 1.00 μm MIN. BOTTOM SIDE : Ni 1.00 μm MIN.(THERE IS THE POSSIBILITY THAT Au ATTACHES RANDOMLY) Au 0.03 μm MIN. OVER Ni 1.00 μm MIN.	TOP SIDE : Ni 1.00 μm MIN.(THERE IS THE POSSIBILITY THAT Au ATTACHES RANDOMLY) BOTTOM SIDE : Au 0.03 μm MIN. OVER Ni 1.00 μm MIN.

NO.	DISCRIPTION	MATERIAL	FINISH, REMARKS
5	PULL-BAR	SUS	
4	SHELL-B	PHOSPHOR BRONZE	SEE ABOVE TABLE.1
3	SHELL-A	PHOSPHOR BRONZE	SEE ABOVE TABLE.1
2	CONTACT	PHOSPHOR BRONZE	SEE ABOVE TABLE.1
1	HOUSING	LCP	UL94V-0, BLACK

REV.	ECN	BY	DATE	APP.	APP.	DWG. No.	SERIES No.	TITLE	SCALE	CUSTOMER COPY	
37	Z250299	K.Ta	Feb./26/'25	T.M	ANGLE ±2°	6 OVER 30 MAX. ±0.3	R11R3R0	CABLINER [®] -VS PLUG CABLE ASSEMBLY	5:1	I-PEX	
36	Z241657	T.Ono	Nov./22/'24	T.M	6 MAX. ±0.2	30 OVER 120 MAX. ±0.5		mm			
35	Z241418	T.Ono	Oct./11/'24	T.M	GENERAL TOLERANCE.						
34	Z231013	T.Ono	Sept./27/'23	T.M	DWG. H.Ikari	DATE 2007/09/27					
33	Z211561	R.M	Dec./21/'21	H.I	CHK. -						
32	Z211259	R.M	Oct./18/'21	H.I							
REV.	ECN	BY	DATE	APP.	APP.	DWG. No.	20453		SIZE A3	SHEET 1/6	REV. 37

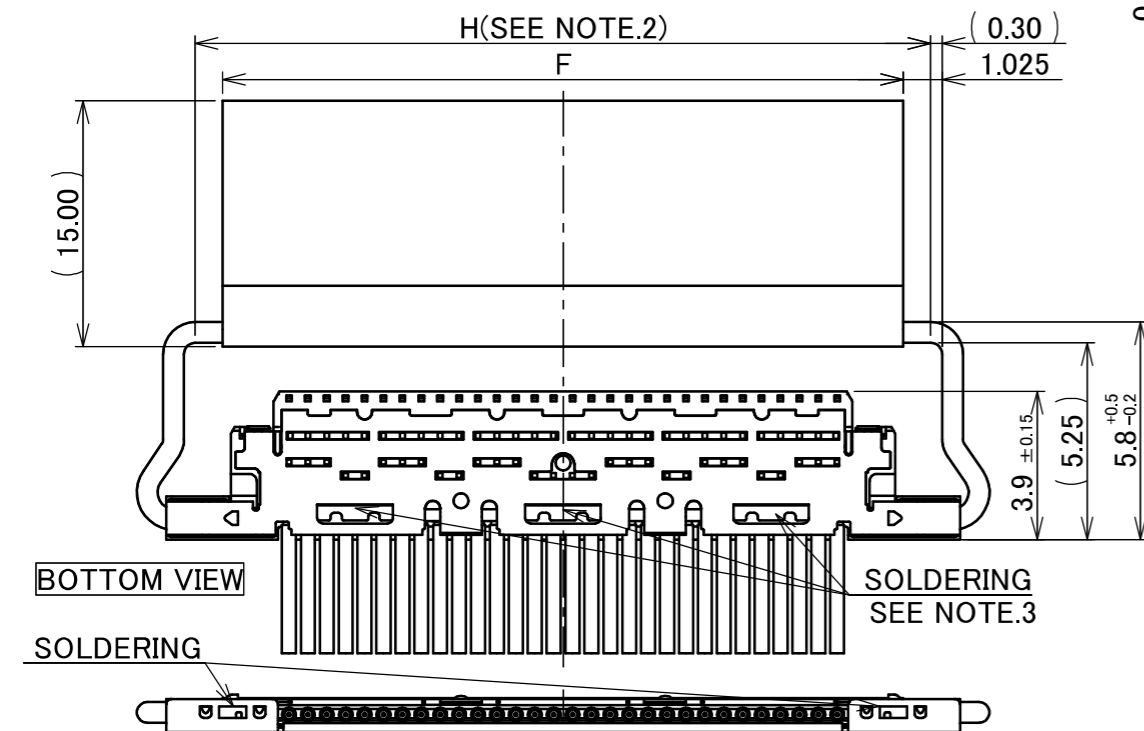

NOTES.
 1.RECOMMENDED PULL-TAPE
 PULL-TAPE : TERAOKA's INSULATION TAPE No.650S(#50) t=0.08
 2.PULL-TAPE CAN BE PUT WITHIN THE RANGE OF "H"(STRAIGHT AREA)
 3.SOLDERING IS ONLY A CASE WITH GND-BAR

PATENT REGISTERED

PART NO.	Pos.	A	B	C	D
20453-#20T-#2	20	9.50	10.30	12.56	16.00
20453-#30T-#2	30	14.50	15.30	17.56	21.00
20453-#40T-#2	40	19.50	20.30	22.56	26.00
20453-#50T-#2S	50	24.50	25.30	27.56	31.00

WITHOUT PULL-BAR

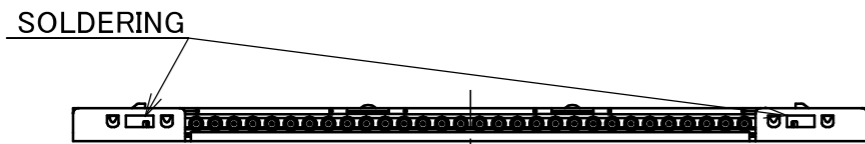
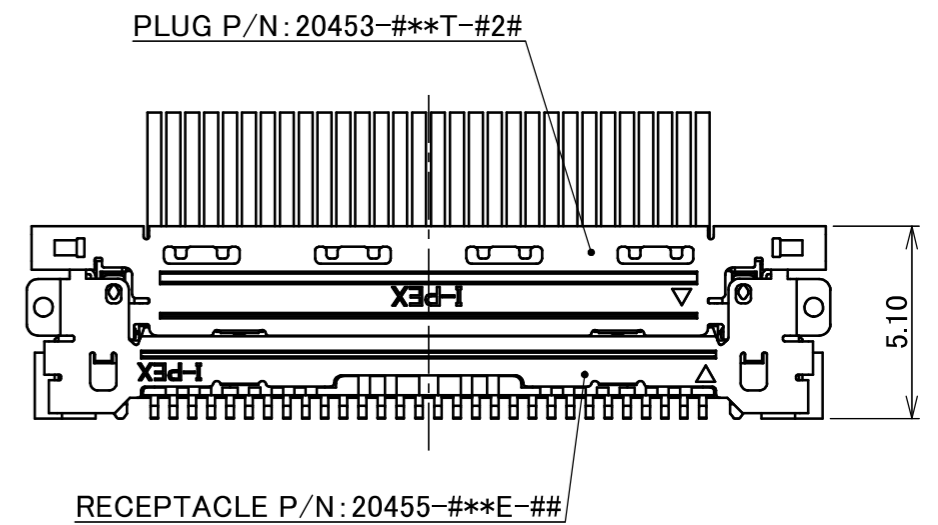
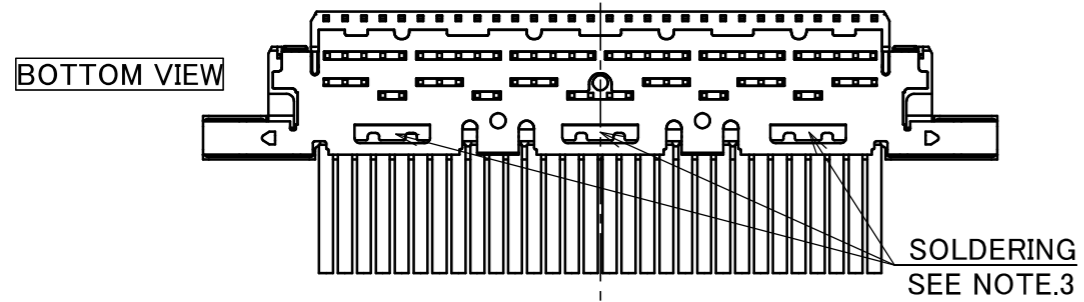
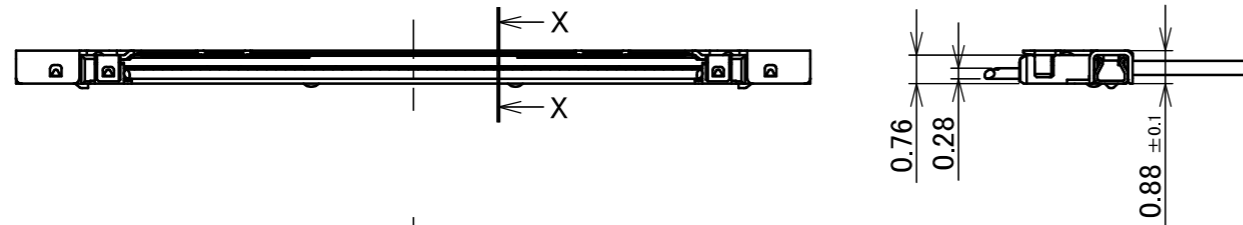
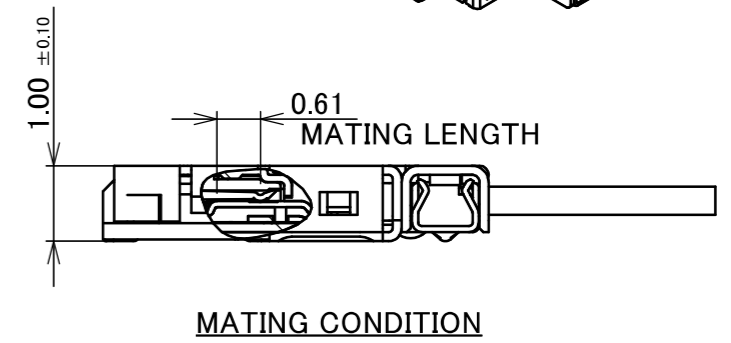
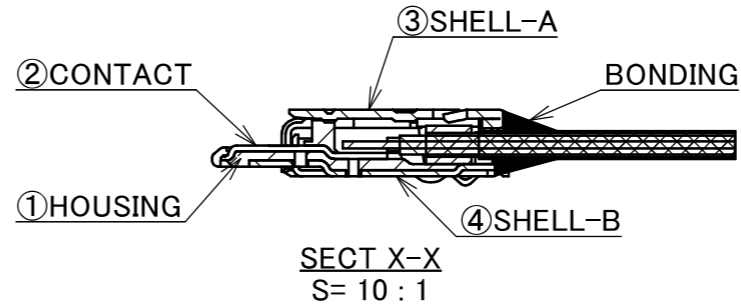
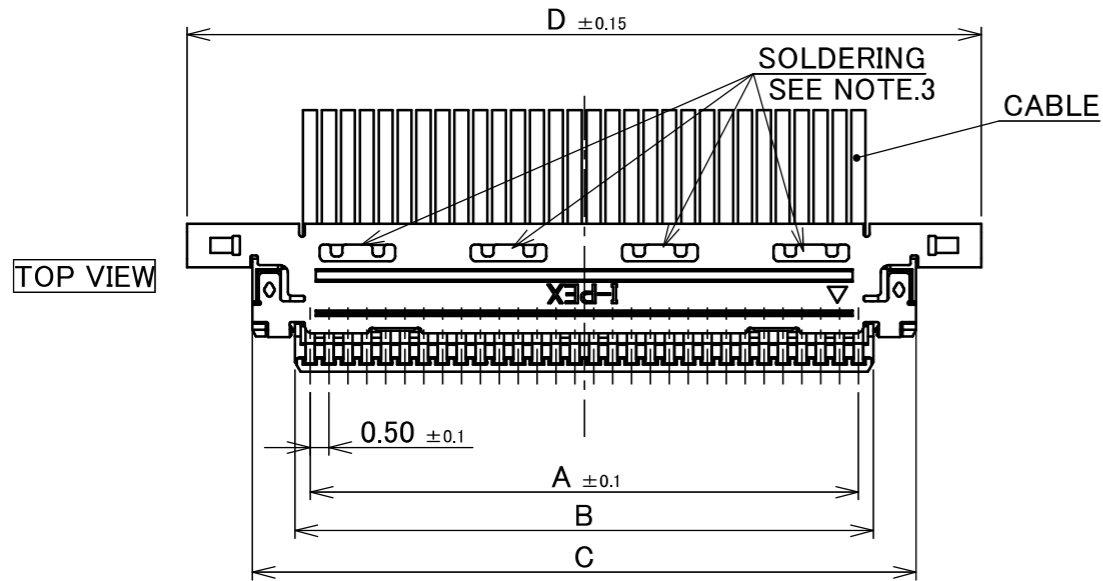
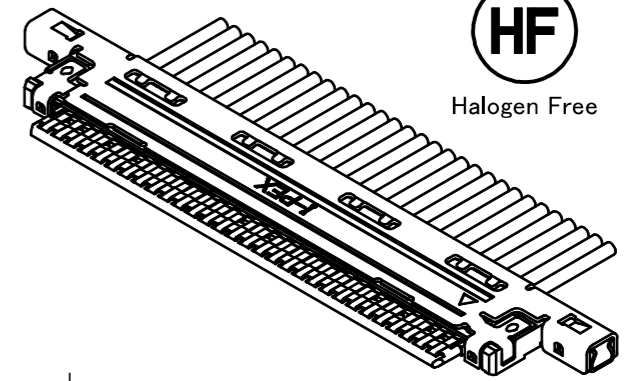

PATENT REGISTERED

PART NO.			
CABLE ASS'Y PART NO.	HOUSING ASS'Y PART NO.	SHELL-A PART NO.	PULL-BAR PART NO.
20453-0**T-#2#	20454-0**T-##	2574-###	-
20453-2**T-#2#	20454-2**T-##	2574-###2	-

ANGLE	±2°	6 OVER 30 MAX.	±0.3	PROJECTION ⊕	SERIES No. R11R3R0	CUSTOMER COPY		
6 MAX.	±0.2	30 OVER 120 MAX.	±0.5					
GENERAL TOLERANCE.				TITLE CABLIN [®] -VS PLUG CABLE ASSEMBLY	SCALE 5:1 UNIT mm	I-PEX		
DWG.	DATE							
CHK.								
APP.								
				DWG. No.	20453	SIZE	SHEET	REV.
						A3	2/6	37

Recommended P/N 20453-2**T-03(20P/30P/40P) 20453-250T-03S(50P)

PART NO.	Pos.	A	B	C	D	E	G
20453-#20T-#3	20	9.50	10.30	12.56	16.00	16.15	17.55
20453-#30T-#3	30	14.50	15.30	17.56	21.00	21.15	22.55
20453-#40T-#3	40	19.50	20.30	22.56	26.00	26.15	27.55
20453-#50T-#3S	50	24.50	25.30	27.56	31.00	31.15	32.55

WITH INSULATION COAT PULL-BAR

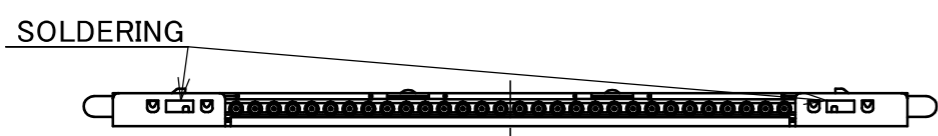
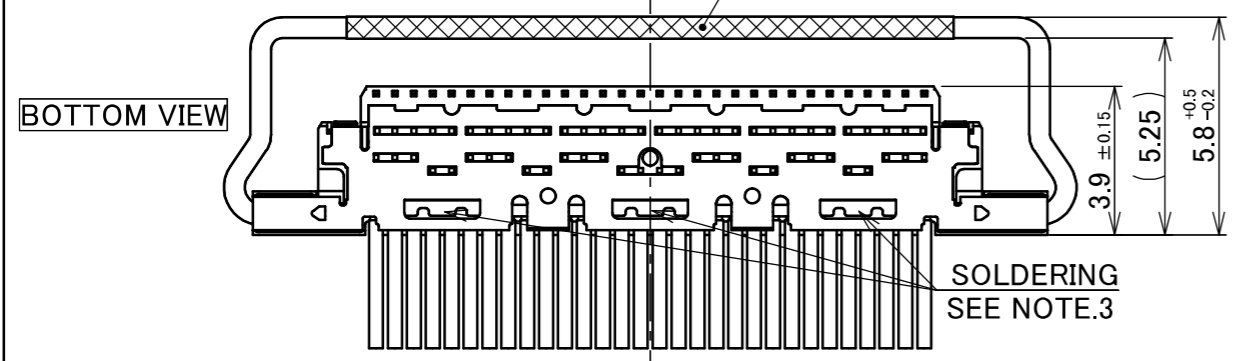
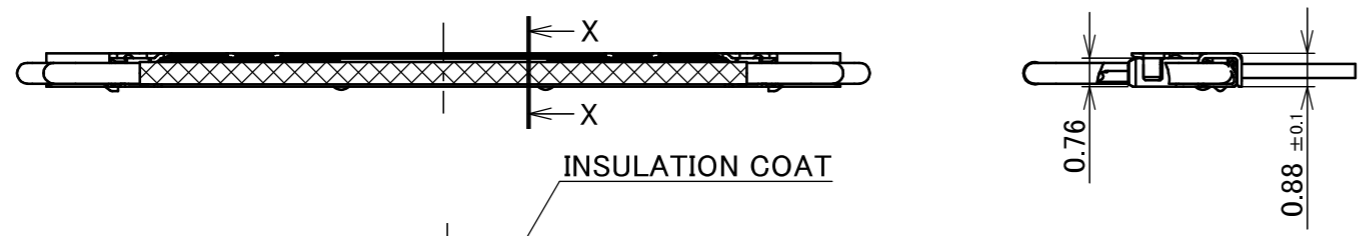
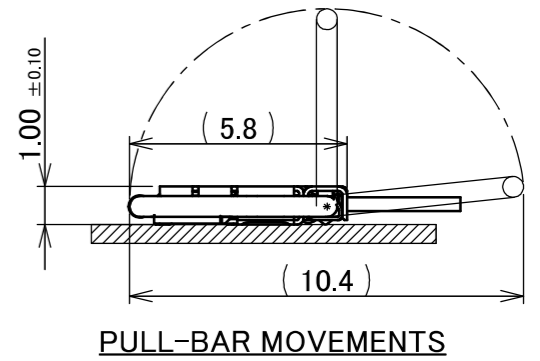
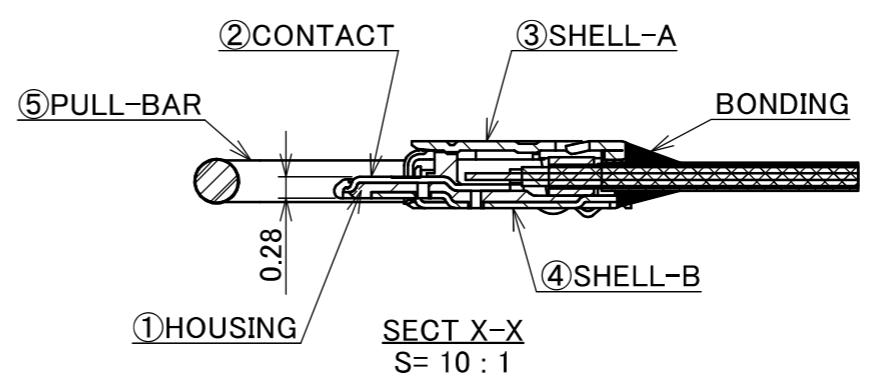
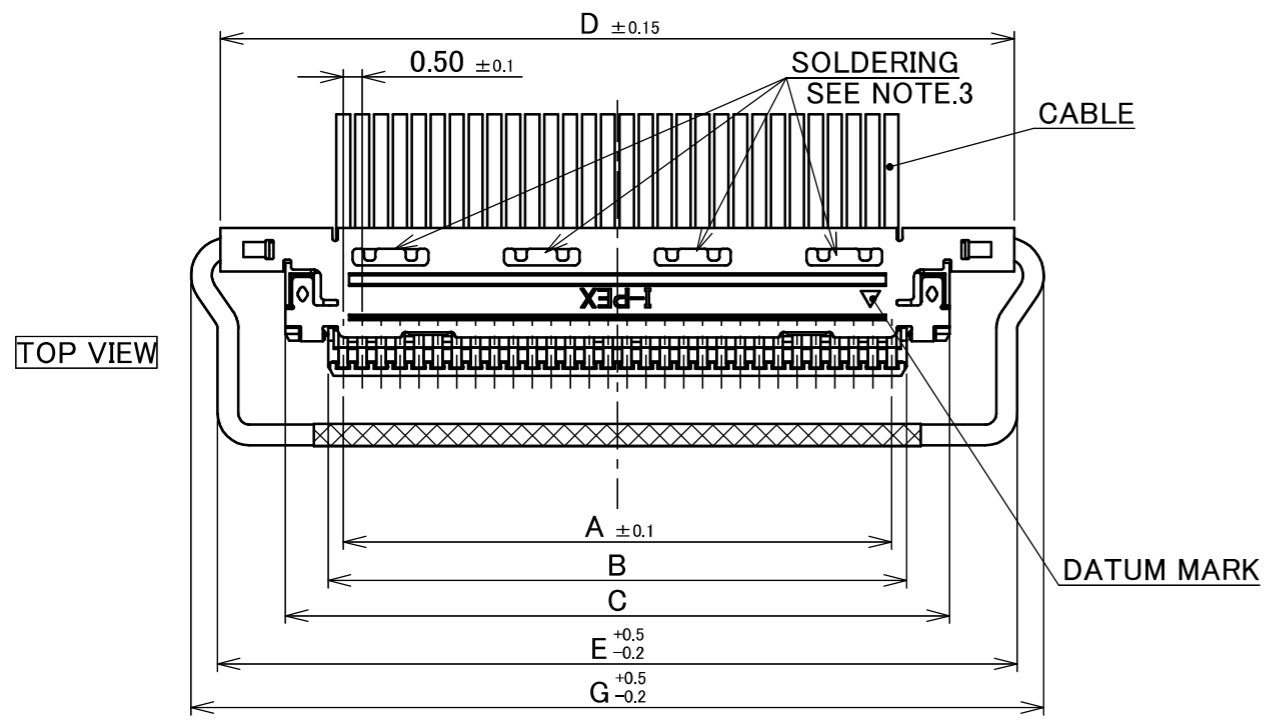
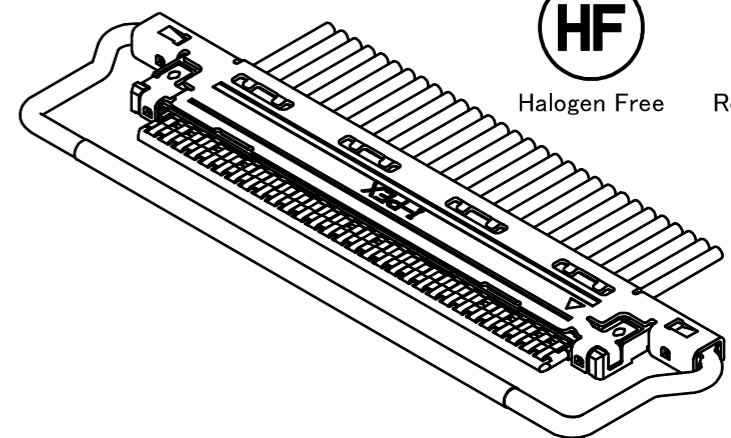

PART NO.			
CABLE ASS'Y PART NO.	HOUSING ASS'Y PART NO.	SHELL-A PART NO.	PULL-BAR PART NO.
20453-0**T-#3#	20454-0**T-##	2574-###	2576-1**-00
20453-2**T-#3#	20454-2**T-##	2574-###2	2576-1**-00

ANGLE	$\pm 2^\circ$	6 OVER 30 MAX.	± 0.3	PROJECTION 	SERIES No. R11R3R0	CUSTOMER COPY					
	6 MAX.	± 0.2	30 OVER 120 MAX.						± 0.5		
GENERAL TOLERANCE.				TITLE CABLIN [®] -VS PLUG CABLE ASSEMBLY	SCALE 5:1 UNIT mm	I-PEX					
DWG.	DATE										
CHK.											
APP.											
				DWG. No.	20453	SIZE	A3	SHEET	3/6	REV.	37

PATENT REGISTERED

ITEMS	SPECIFICATION
APPLICABLE CABLE	MICRO-COAXIAL CABLE : AWG# 44, 42, 40, 38, 36 DISCRETE WIRE : AWG# 36, 34, 32 TWINAX CABLE : AWG# 40
RATING VOLTAGE	100V AC (PER CONTACT PIN) ※THIS IS THE RATED VOLTAGE OF THE CONNECTOR. PLEASE NOTE THAT THE RATED VOLTAGE MAY VARY IN THE HARNESS DEPENDING ON THE CABLES USED.
RATING AMPERAGE (FOR CONTACT)	0.1A AC/DC [AWG#44] PER CONTACT PIN/UP TO 50 CONTACTS 0.24A AC/DC [AWG#42] PER CONTACT PIN/UP TO 50 CONTACTS 0.3A AC/DC [AWG#40] PER CONTACT PIN/UP TO 50 CONTACTS 0.5A AC/DC [AWG#38] PER CONTACT PIN/UP TO 14 CONTACTS 0.8A AC/DC [AWG#36] PER CONTACT PIN/UP TO 10 CONTACTS 1.0A AC/DC [AWG#34] PER CONTACT PIN/UP TO 6 CONTACTS 1.0A AC/DC [AWG#32] PER CONTACT PIN/UP TO 6 CONTACTS TESTING BY A REAL MACHINE IS RECOMMENDED BECAUSE TEMPERTURE RISE MAY AFFECTED BY ACTUAL SITUATION.
OPERATING TEMPERATURE	233~358K(-40°C~+85°C)
OPERATING HUMIDITY	85% MAX.
CONTACT RESISTANCE	INITIAL : 140mohm MAX.(AWG#32) / AFTER TEST : \triangle 40mohm MAX. 180mohm MAX.(AWG#34) 275mohm MAX.(AWG#36) 360mohm MAX.(AWG#38) 600mohm MAX.(AWG#40) 700mohm MAX.(AWG#42) 1080mohm MAX.(AWG#44)
GROUND SHELL RESISTANCE	INITIAL : 50mohm MAX. / AFTER TEST : \triangle 40mohm MAX.
INSULATION RESISTANCE	INITIAL : 1000Mohm MIN. / AFTER TEST : 500Mohm MIN.
DIELECTRIC WITHSTANDING VOLTAGE	AC250V 1min
DURABILITY	30 CYCLES
MATING FORCE (INITIAL / AFTER TEST)	20P : 9.45N MAX. 30P : 12.15N MAX. 40P : 16.20N MAX. 50P : 20.25N MAX.
UNMATING FORCE (INITIAL / AFTER TEST)	20P : 2.0N MIN. 30P : 3.0N MIN. 40P : 4.0N MIN. 50P : 5.0N MIN.
CABLE RETENTION FORCE	20P : 9.80N MIN. 30P : 14.70N MIN. 40P : 19.60N MIN. 50P : 24.50N MIN.
PRODUCT SPECIFICATION	PRS-1427
TEST REPORT	TR-08047 (20453-0**T-###) / TR-13084 (20453-2**T-###)
INSTRUCTION MANUAL	HIM-08004
ASSEMBLY MANUAL	ASM-08003
APPEARANCE CRITERIA No.	QLS-A***

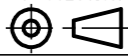
ANGLE	$\pm 2^\circ$	6 OVER 30 MAX.	± 0.3	PROJECTION 	SERIES No. R11R3R0	CUSTOMER COPY						
	6 MAX.	± 0.2	30 OVER 120 MAX.			± 0.5	SCALE	I-PEX				
GENERAL TOLERANCE.					TITLE	UNIT						
DWG.	DATE				CABLIN [®] -VS PLUG CABLE ASSEMBLY	mm						
CHK.						DWG. No.	SIZE				SHEET	REV.
APP.					20453	A3	4/6	37				

PART NO.	Pos.	A
20453-#20T-##	20	9.50
20453-#30T-##	30	14.50
20453-#40T-##	40	19.50
20453-#50T-##S	50	24.50

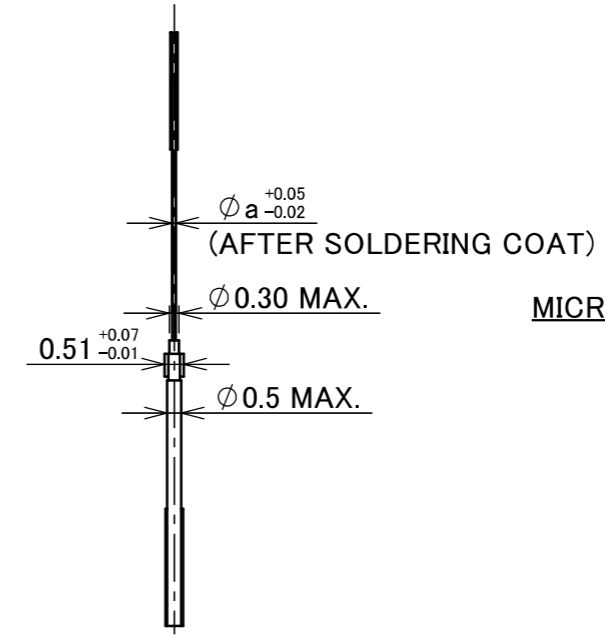
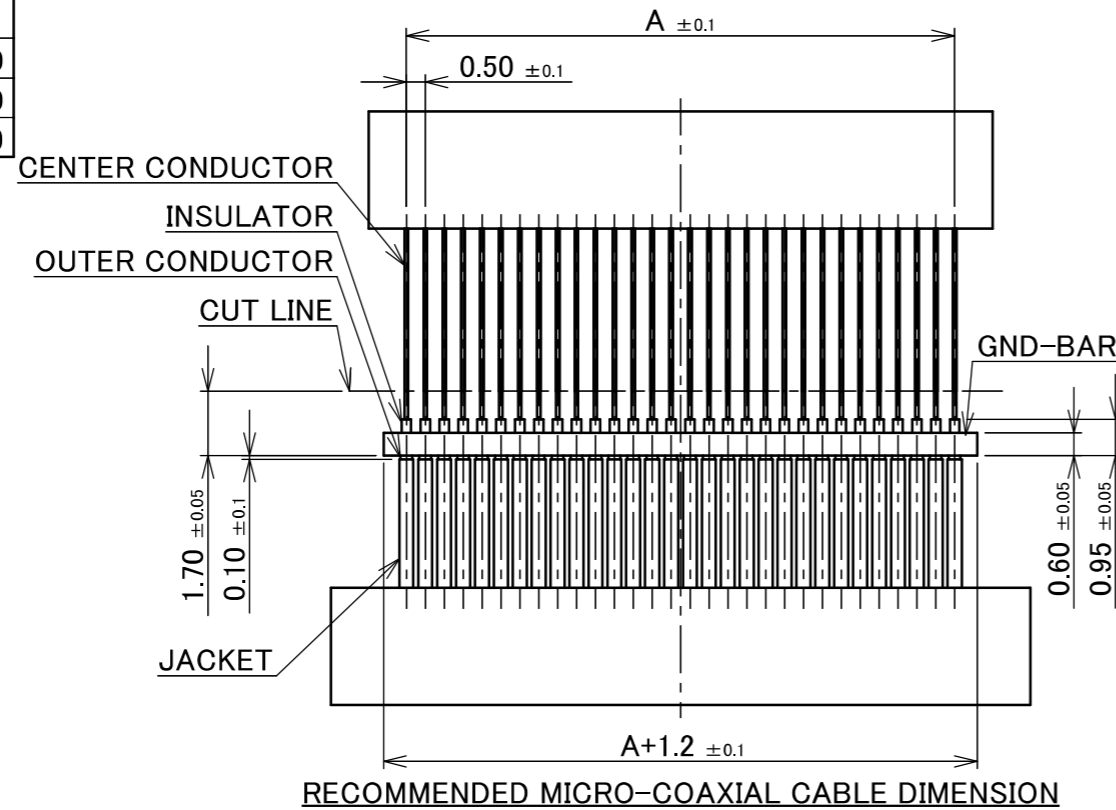

MICRO-COAXIAL CABLE DIMENSION

	a
#36	0.15
#38	0.12
#40	0.09
#42	0.075
#44	0.063

MICRO-COAXIAL CABLE AWG#**

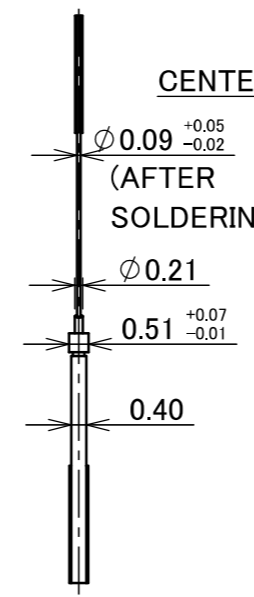
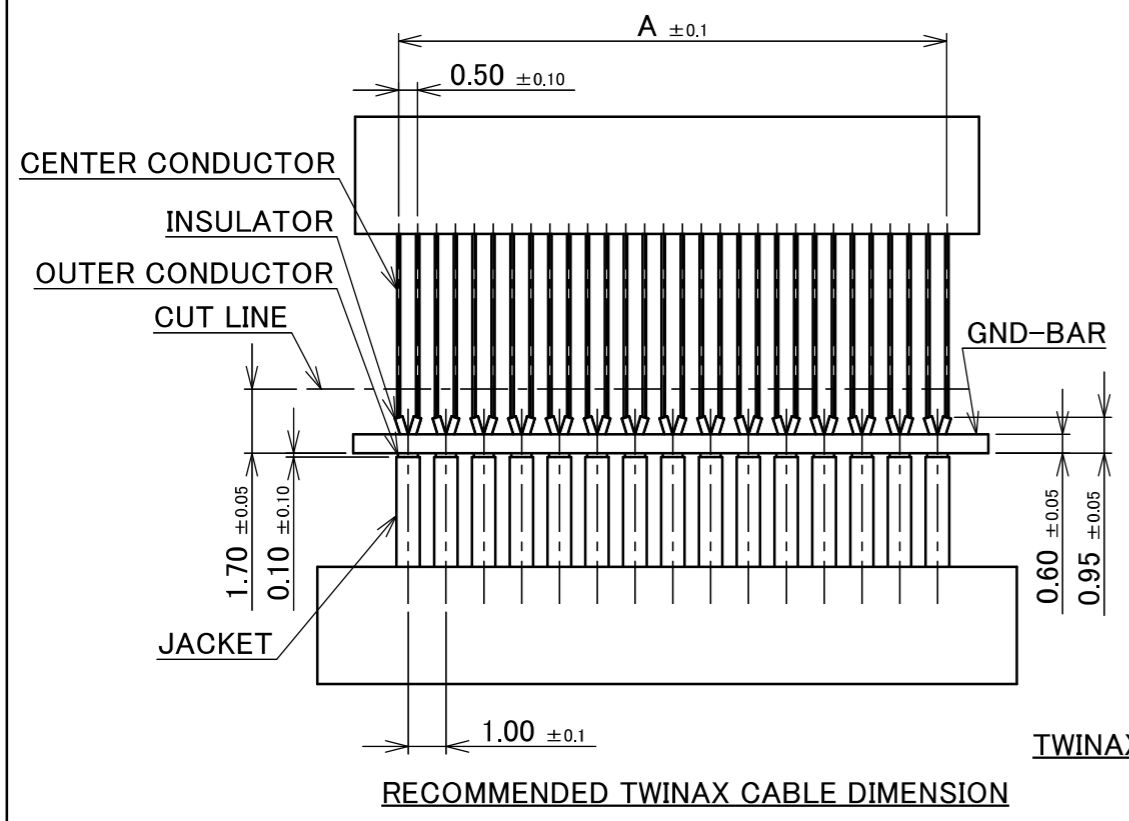

TWINAX CABLE AWG#40

RECOMMENDED TWINAX CABLE DIMENSION

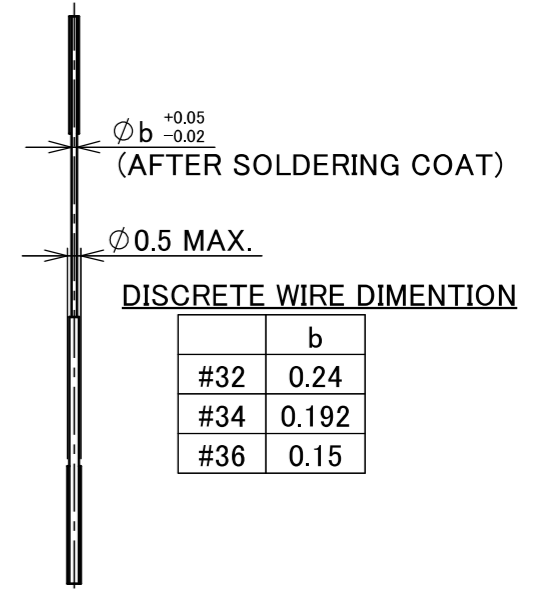
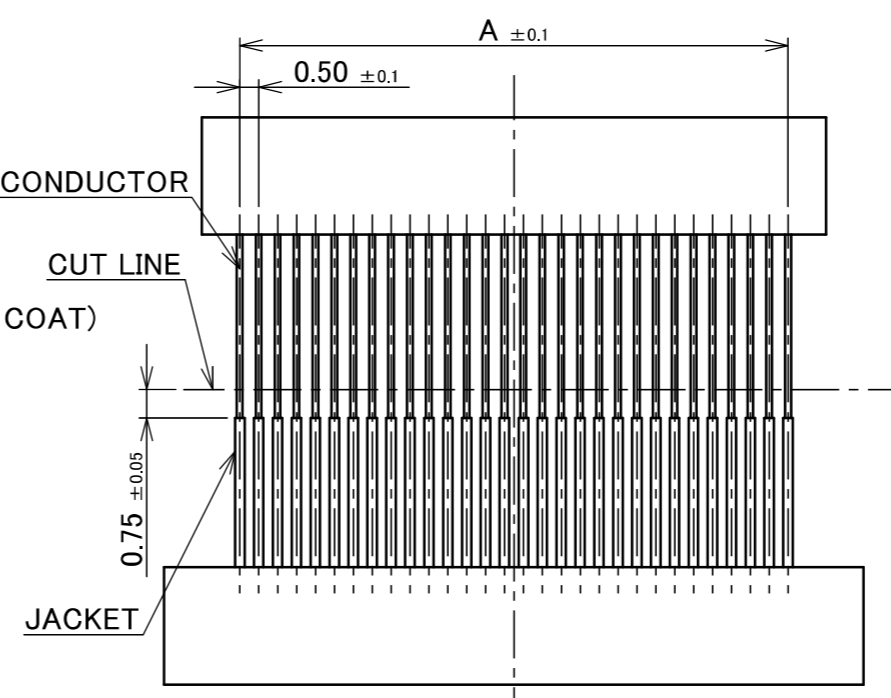

DISCRETE WIRE DIMENTION

	b
#32	0.24
#34	0.192
#36	0.15

DISCRETE WIRE AWG#**

RECOMMENDED DISCRETE WIRE DIMENSION

ANGLE	±2°	6 OVER 30 MAX.	±0.3	PROJECTION ⊕	SERIES No. R11R3R0	CUSTOMER COPY		
	6 MAX.	±0.2	30 OVER 120 MAX.					
GENERAL TOLERANCE.				TITLE CABLIN [®] -VS PLUG CABLE ASSEMBLY	SCALE 5:1 UNIT mm	I-PEX		
DWG.	DATE							
CHK.								
APP.								
				DWG. No.	20453	SIZE A3	SHEET 5/6	REV. 37

THE EXTERNAL APPEARANCE

20P

TOP VIEW

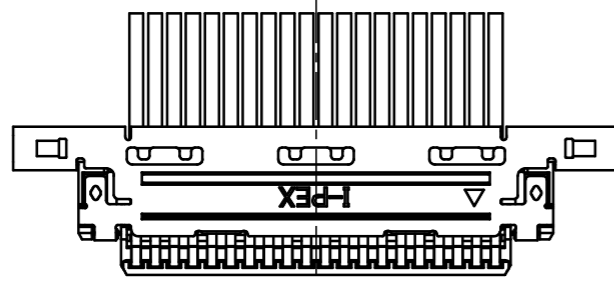

BOTTOM VIEW

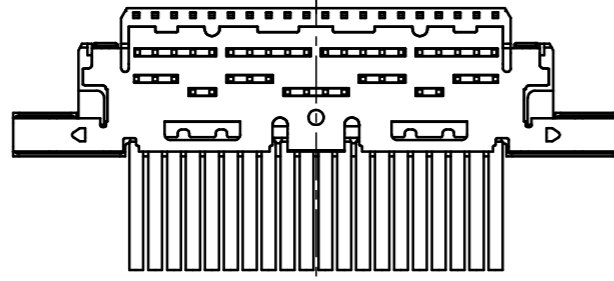

40P

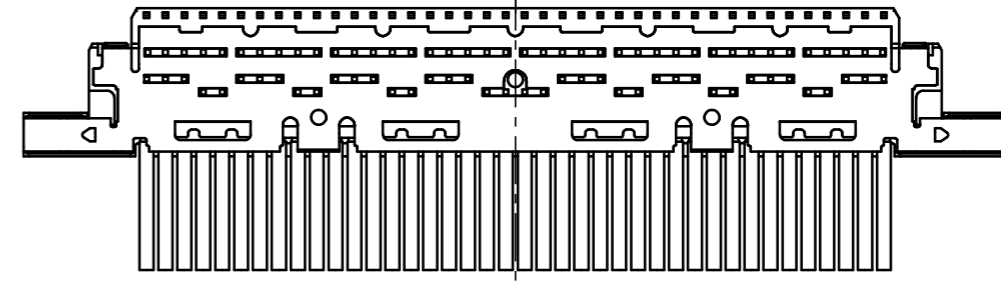
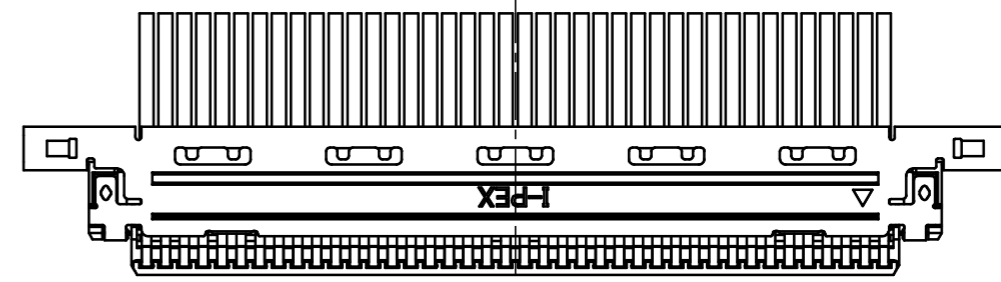

30P

TOP VIEW

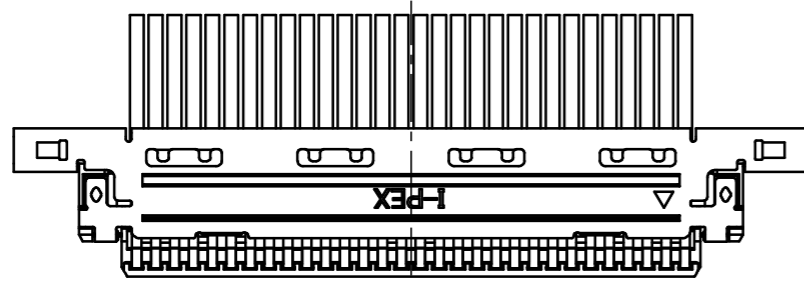

BOTTOM VIEW

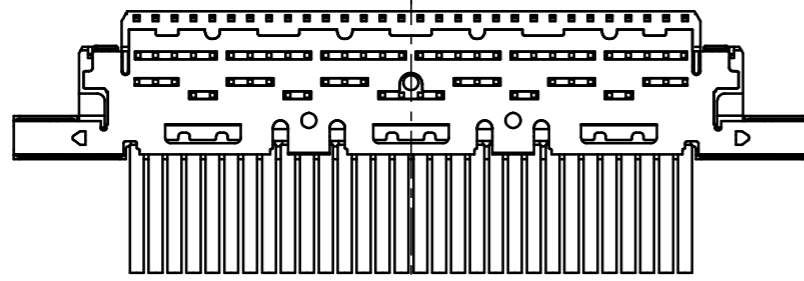

50P

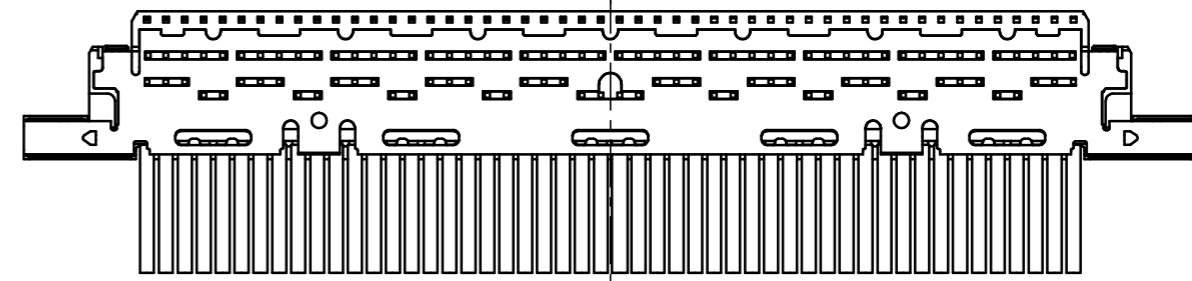
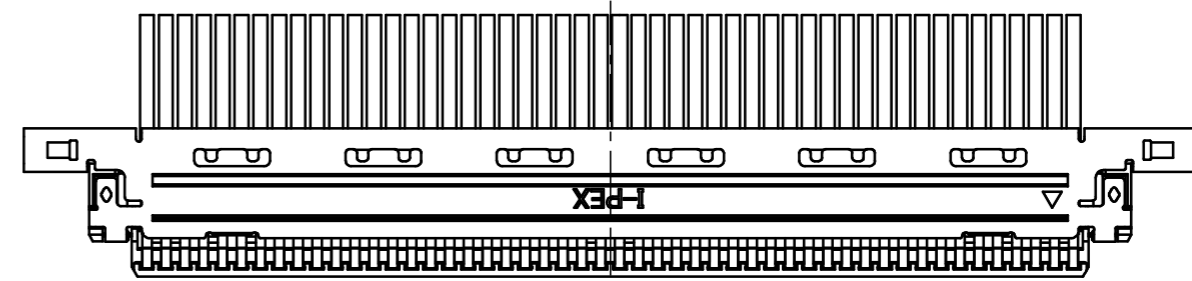

ANGLE	$\pm 2^\circ$	6 OVER 30 MAX.	± 0.3	PROJECTION 	SERIES No. R11R3R0	CUSTOMER COPY		
6 MAX.	± 0.2	30 OVER 120 MAX.	± 0.5					
GENERAL TOLERANCE.				TITLE CABLIN [®] -VS PLUG CABLE ASSEMBLY	SCALE 5:1 UNIT mm	I-PEX		
DWG.	DATE							
CHK.								
APP.								
				DWG. No.	20453	SIZE A3	SHEET 6/6	REV. 37