

Recommended P/N 20849-0**E-01

PART NO.	Pos.	A	B	C	D	E
20849-020E-0#	20	11.30	9.50	14.33	15.10	11.91
20849-030E-0#	30	16.30	14.50	19.33	20.10	16.91
20849-040E-0#	40	21.30	19.50	24.33	25.10	21.91

P/N : 20849- 0 ** E- 0 #
SEE TABLE 1
POS.

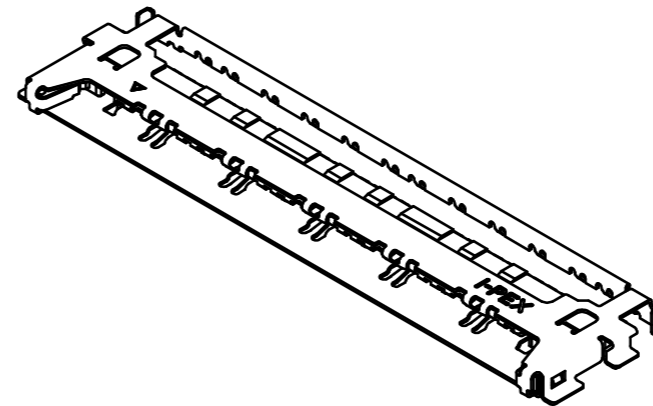
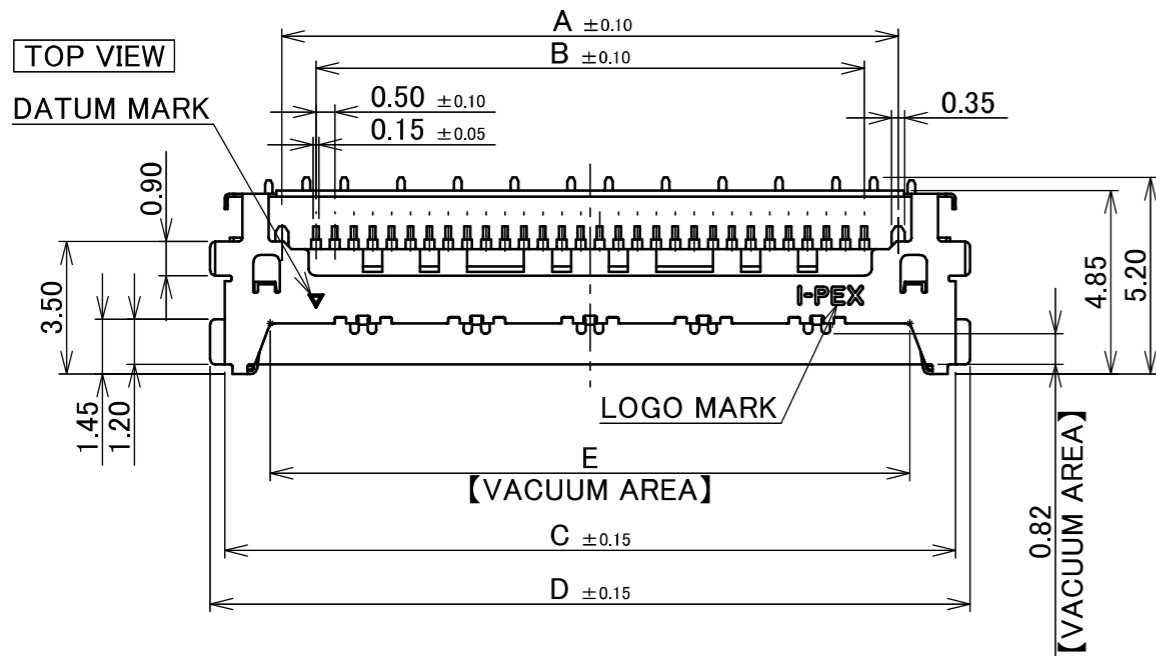
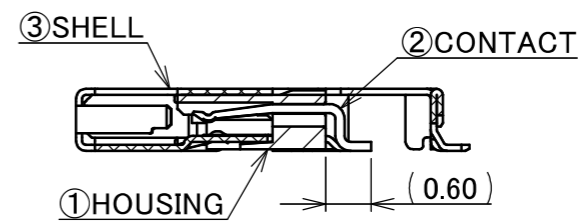

SECT. W-W
(S = 10 : 1)

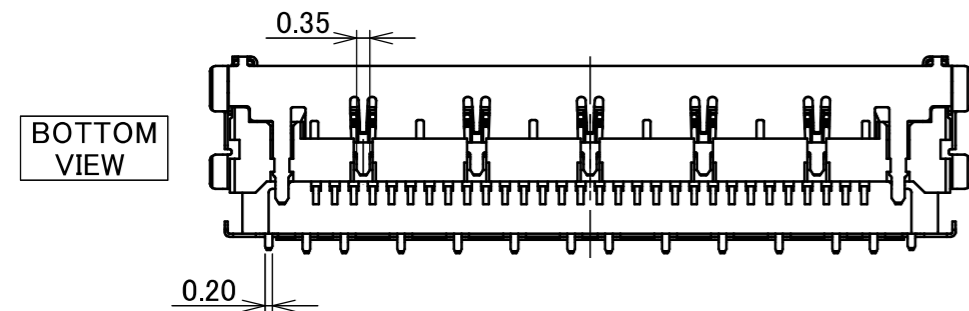
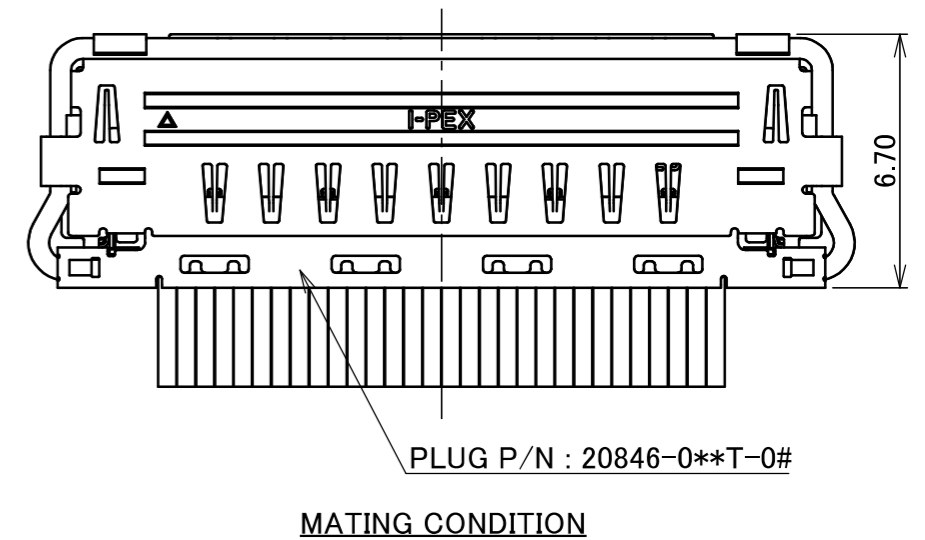
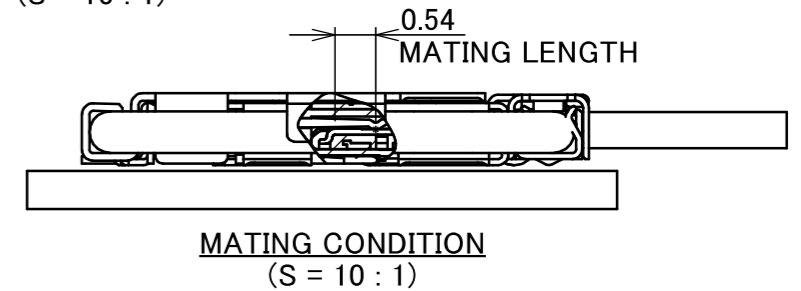

TABLE.1

PART NO.	CONTACT FINISH	SHELL FINISH
20849-0**E-01	CONTACT & SOLDERING AREA : Au 0.03 μm MIN. OVER Ni 1.00 μm MIN.	ALL OVER Ni 1.00 μm MIN. SOLDERING AREA : Au 0.02 μm MIN.
20849-0**E-02	CONTACT AREA : Au 0.38 μm MIN. OVER Ni 1.27 μm MIN. SOLDERING AREA : Au 0.03 μm MIN. OVER Ni 1.00 μm MIN.	

NO.	DISCRIPTION	MATERIAL	FINISH , REMARKS
3	SHELL	PHOSPHOR BRONZE	SEE TABLE 1
2	CONTACT	PHOSPHOR BRONZE	SEE TABLE 1
1	HOUSING	LCP	UL94V-0, BLACK

REV.	ECN	BY	DATE	APP.	APP.	PROJECTION	SERIES No.	TITLE	SCALE	SHEET	REV.
14	Z250308	K.Ta	Feb./27/'25	T.M	ANGLE ±2° 6 OVER 30 MAX. ±0.3		R2	CABLINER [®] -VS II RECEPTACLE ASSEMBLY	5:1	mm	14
13	Z241820	T.Ono	Dec./18/'24	T.M	6 MAX. ±0.2 30 OVER 120 MAX. ±0.5						
12	Z241779	T.Ono	Dec./12/'24	T.M	GENERAL TOLERANCE.						
11	Z240932	K.Hara	July/16/'24	H.I	DWG. K.Baba DATE 2017/07/25						
10	Z231032	H.U	Sep./26/'23	M.T	CHK. T.Kurachi						
9	Z230311	Y.I	Mar./17/'23	M.T	APP. Y.Shimada						
REV.	ECN	BY	DATE	APP.	APP.	DWG. No.	20849		A3	1/9	

PATENT REGISTERED

PART NO.	Pos.
20849-020E-0#	20
20849-030E-0#	30
20849-040E-0#	40

BOTTOM VIEW

PATENT REGISTERED

20P

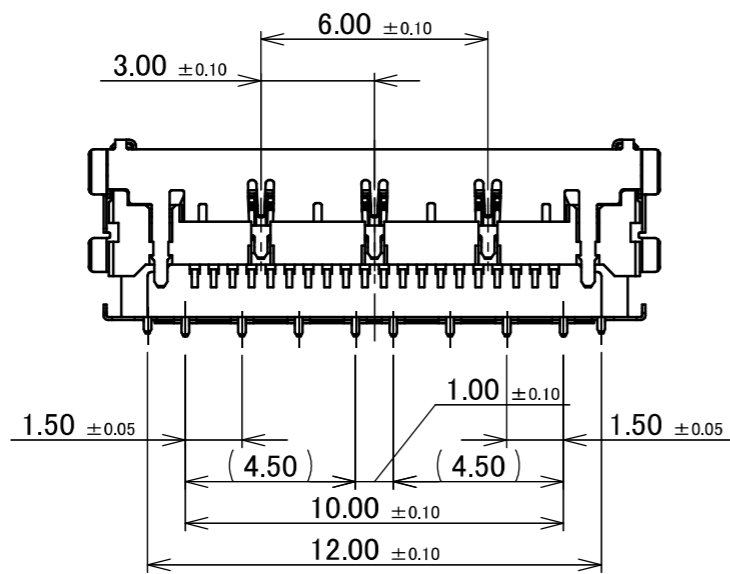

30P

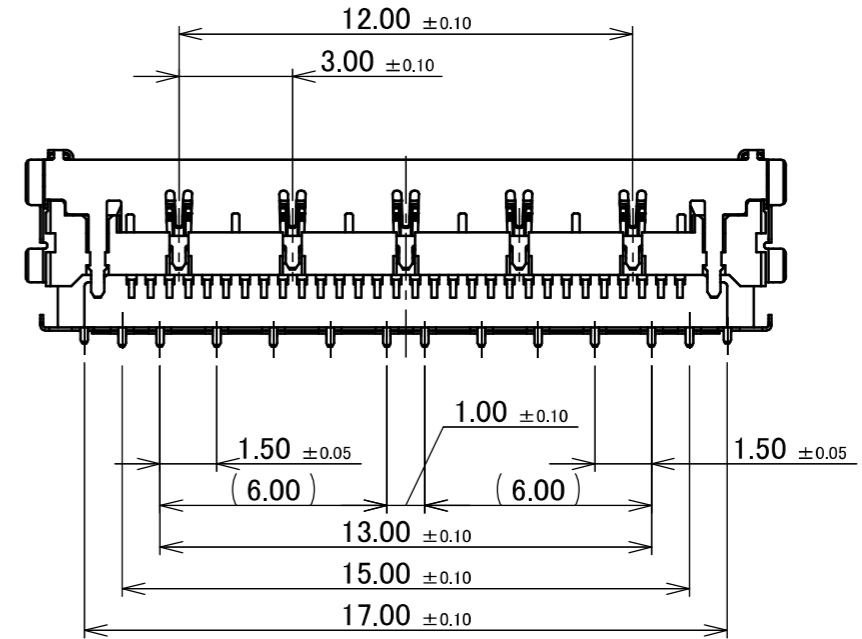

40P

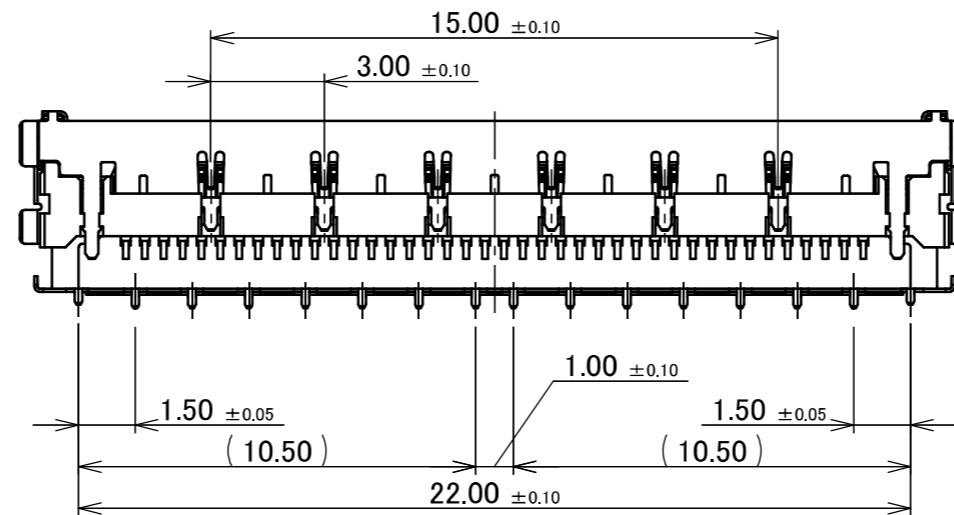

ANGLE	±2°	6 OVER 30 MAX.	±0.3	PROJECTION ⊕	SERIES No. R2	CUSTOMER COPY		
6 MAX.	±0.2	30 OVER 120 MAX.	±0.5					
GENERAL TOLERANCE.				TITLE CABLINÉ® -VS II RECEPTACLE ASSEMBLY	SCALE 5:1 UNIT mm	I-PEX		
DWG.	DATE							
CHK.								
APP.								
				DWG. No.	20849	SIZE A3	SHEET 2/9	REV. 14

FOR CABLINE-VS II PLUG CABLE ASSEMBLY (DWG NO. 20846)

ITEMS	SPECIFICATION
APPLICABLE CABLE	MICRO-COAXIAL CABLE : AWG# 44 , 42 , 40 , 38 , 36 DISCRETE WIRE : AWG# 36 , 34 , 32 TWINAX CABLE : AWG# 40
RATING VOLTAGE	100V AC (PER CONTACT PIN) ※THIS IS THE RATED VOLTAGE OF THE CONNECTOR. PLEASE NOTE THAT THE RATED VOLTAGE MAY VARY IN THE HARNESS DEPENDING ON THE CABLES USED.
RATING AMPERAGE (FOR CONTACT)	0.1A AC/DC [AWG#44] PER CONTACT PIN/UP TO 40 CONTACTS 0.24A AC/DC [AWG#42] PER CONTACT PIN/UP TO 40 CONTACTS 0.3A AC/DC [AWG#40] PER CONTACT PIN/UP TO 40 CONTACTS 0.5A AC/DC [AWG#38] PER CONTACT PIN/UP TO 23 CONTACTS 0.8A AC/DC [AWG#36] PER CONTACT PIN/UP TO 10 CONTACTS 1.0A AC/DC [AWG#34] FOR POWER PER CONTACT PIN/UP TO 9 CONTACTS 1.0A AC/DC [AWG#32] FOR POWER PER CONTACT PIN/UP TO 9 CONTACTS ※TESTING BY A REAL MACHINE IS RECOMMENDED BECAUSE TEMPERATURE RISE MAY AFFECTED BY ACTUAL SITUATION.
OPERATING TEMPERATURE	233~378K(-40°C~+105°C)
OPERATING HUMIDITY	85% MAX.
CONTACT RESISTANCE	INITIAL : 140mohm MAX.(AWG#32) / AFTER TEST : \triangleleft 40mohm MAX. 180mohm MAX.(AWG#34) 275mohm MAX.(AWG#36) 360mohm MAX.(AWG#38) 600mohm MAX.(AWG#40) 700mohm MAX.(AWG#42) 1080mohm MAX.(AWG#44)
GROUND SHELL RESISTANCE	INITIAL : 50mohm MAX. / AFTER TEST : \triangleleft 40mohm MAX.
INSULATION RESISTANCE	INITIAL : 1000Mohm MIN. / AFTER TEST : 500Mohm MIN.
DIELECTRIC WITHSTANDING VOLTAGE	AC250V 1min
DURABILITY	30 CYCLES
MATING FORCE (INITIAL / AFTER 30 CYCLES)	20P : 9.70N MAX. / 30P : 14.55N MAX. / 40P : 19.40N MAX.
UNMATING FORCE (INITIAL / AFTER 30 CYCLES)	20P : 2.00N MIN. / 30P : 3.00N MIN. / 40P : 4.00N MIN.
CABLE RETENTION FORCE	20P : 9.80N MIN. / 30P : 14.70N MIN. / 40P : 19.60N MIN.
COPLANARITY	0.10 MAX.
PRODUCT SPECIFICATION	PRS-2398
TEST REPORT	TR-17060 (20849-0**E-01) / TR-18048 (20849-0**E-02)
PACKING STANDARD	PST-17079
INSTRUCTION MANUAL	HIM-17015
ASSEMBLY MANUAL	ASM-17005
APPEARANCE CRITERIA No.	QLS-A***

ANGLE	$\pm 2^\circ$	6 OVER 30 MAX.	± 0.3	PROJECTION 	SERIES No. R2	CUSTOMER COPY		
	6 MAX.	± 0.2	30 OVER 120 MAX.			± 0.5		
GENERAL TOLERANCE.				TITLE CABLINE® -VS II RECEPTACLE ASSEMBLY	SCALE mm			
DWG.	DATE							
CHK.								
APP.								
				DWG. No.	20849	SIZE	SHEET	REV.
						A3	3/9	14

FOR CABLINE-VS IIF PLUG SHELL ASSEMBLY (DWG NO. 20862)

ITEMS	SPECIFICATION
RATING VOLTAGE	100V AC (PER CONTACT PIN)
RATING AMPERAGE (FOR CONTACT)	0.3A AC/DC (PER CONTACT PIN) ※TESTING BY A REAL MACHINE IS RECOMMENDED BECAUSE TEMPERATURE RISE MAY AFFECTED BY ACTUAL SITUATION.
OPERATING TEMPERATURE	233~358K(-40°C~+85°C)
OPERATING HUMIDITY	85% MAX.
CONTACT RESISTANCE (FOR SIGNAL CONTACT)	INITIAL : 60mohm MAX. / AFTER TEST : \triangle 40mohm MAX.
GROUND SHELL RESISTANCE	INITIAL : 60mohm MAX. / AFTER TEST : \triangle 40mohm MAX.
INSULATION RESISTANCE	INITIAL : 1000Mohm MIN. / AFTER TEST : 500Mohm MIN.
DIELECTRIC WITHSTANDING VOLTAGE	AC250V 1min
DURABILITY	30 CYCLES
MATING FORCE (INITIAL / AFTER TEST)	30P : 13.50N MAX. 40P : 18.00N MAX.
UNMATING FORCE (INITIAL / AFTER TEST)	30P : 1.44N MIN. 40P : 1.92N MIN.
COPLANARITY	0.10 MAX.
PRODUCT SPECIFICATION	PRS-2430
TEST REPORT	TR-17086
PACKING STANDARD	PST-17079
INSTRUCTION MANUAL	HIM-17039
APPEARANCE CRITERIA NO.	QLS-A***

ANGLE	$\pm 2^\circ$	6 OVER 30 MAX.	± 0.3	PROJECTION 	SERIES No. R2	CUSTOMER COPY		
6 MAX.	± 0.2	30 OVER 120 MAX.	± 0.5					
GENERAL TOLERANCE.				TITLE CABLINE® -VS II RECEPTACLE ASSEMBLY	SCALE	I-PEX		
DWG.	DATE							
CHK.								
APP.								
				DWG. No.	20849	SIZE	SHEET	REV.
						A3	4/9	14

PATENT REGISTERED

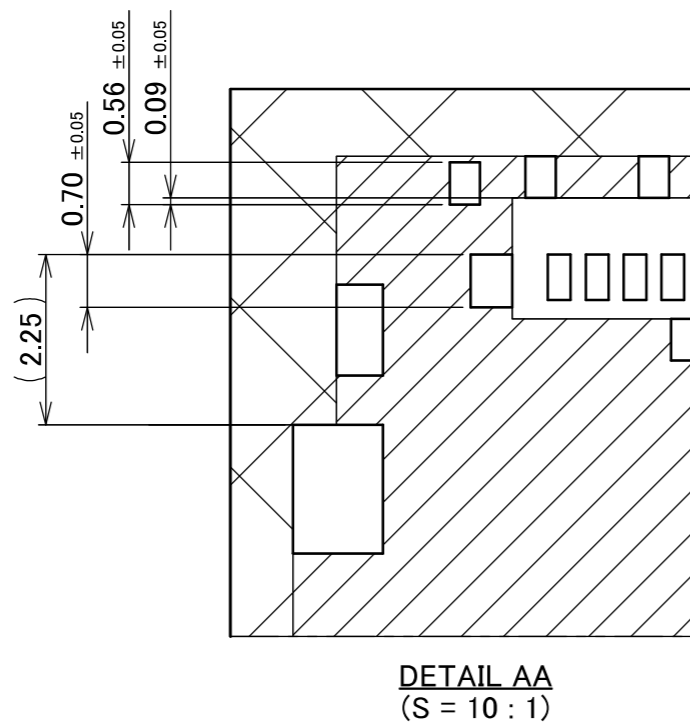
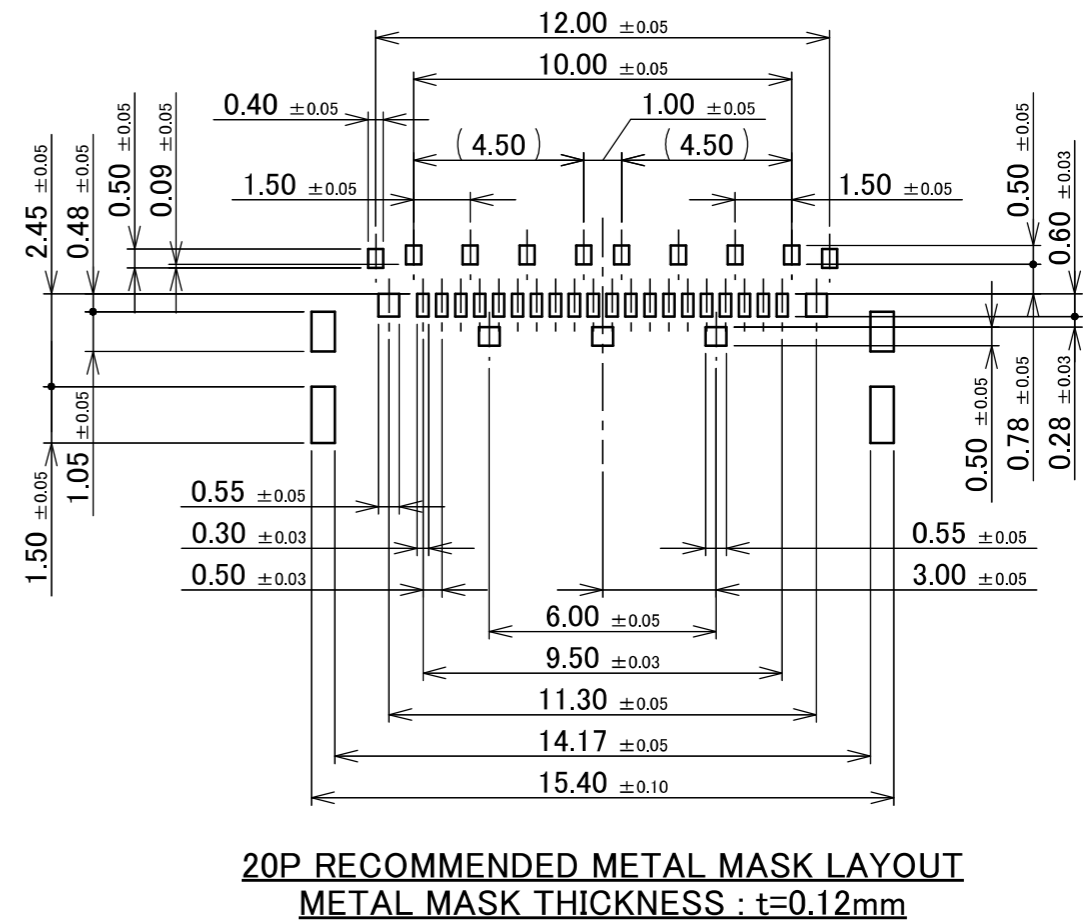
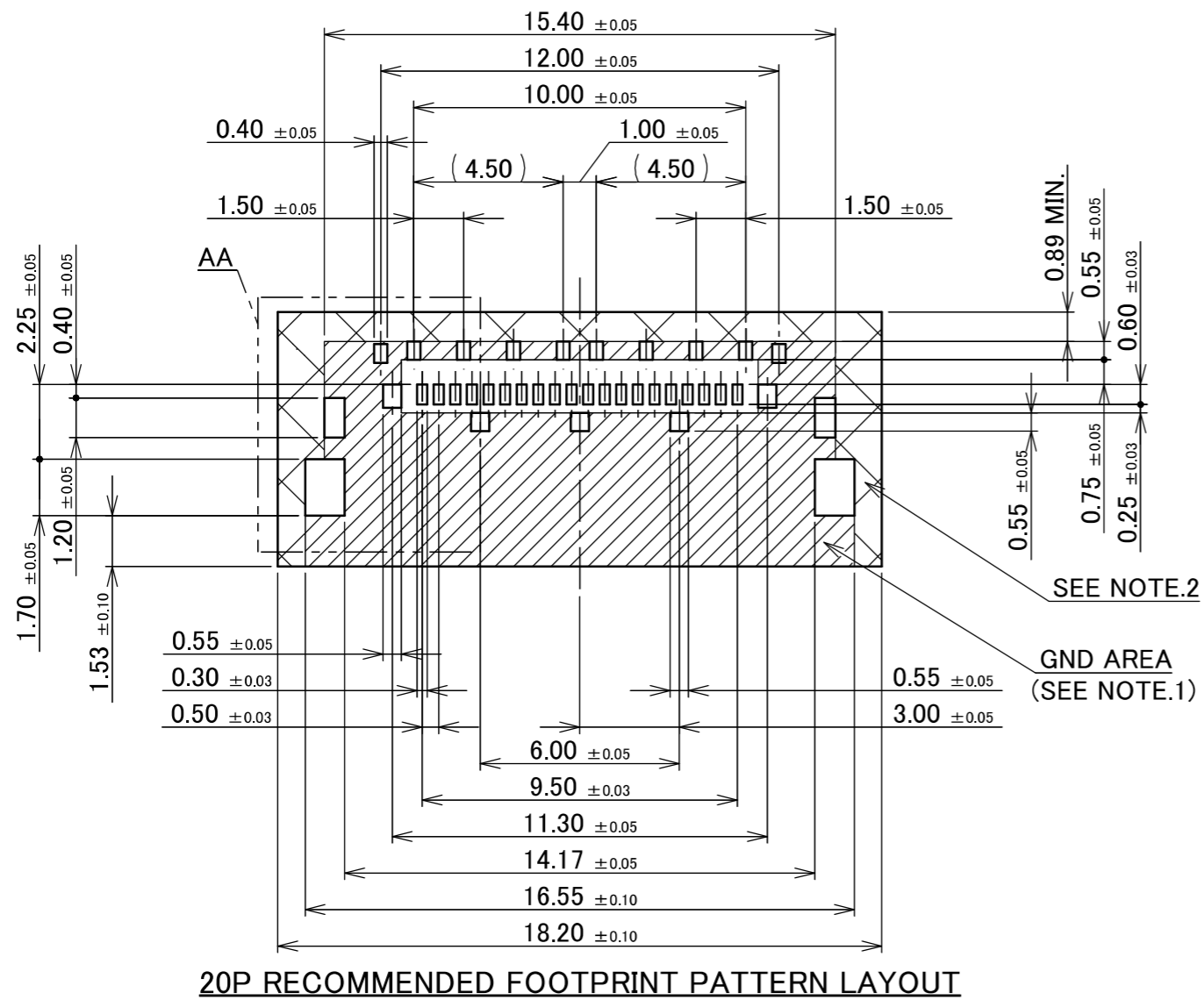

- NOTES.
1. SOLDER RESIST MUST BE APPLIED TO THIS AREA.
 2. DO NOT MOUNT ANOTHER COMPONENT IN THIS AREA.

ANGLE	±2°	6 OVER 30 MAX.	±0.3	PROJECTION ⊕	SERIES No. R2	CUSTOMER COPY			
	6 MAX.	±0.2	30 OVER 120 MAX.						±0.5
GENERAL TOLERANCE.				TITLE		SCALE	I-PEX		
DWG.	DATE			CABLIN [®] -VS II RECEPTACLE ASSEMBLY		5:1			
CHK.						UNIT			
APP.				DWG. No.		mm			
				20849		SIZE	SHEET	REV.	
						A3	5/9	14	

PATENT REGISTERED

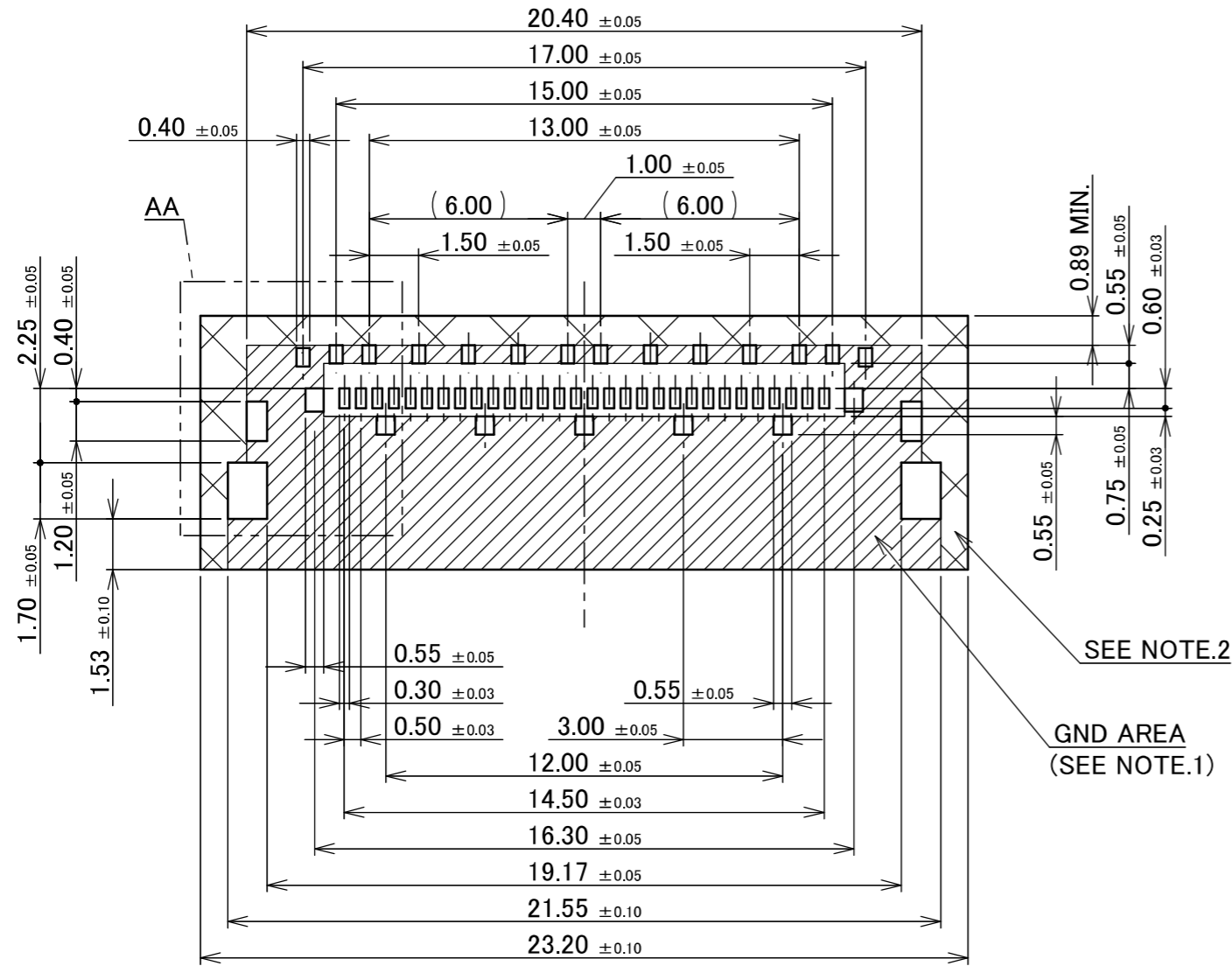

30P RECOMMENDED FOOTPRINT PATTERN LAYOUT

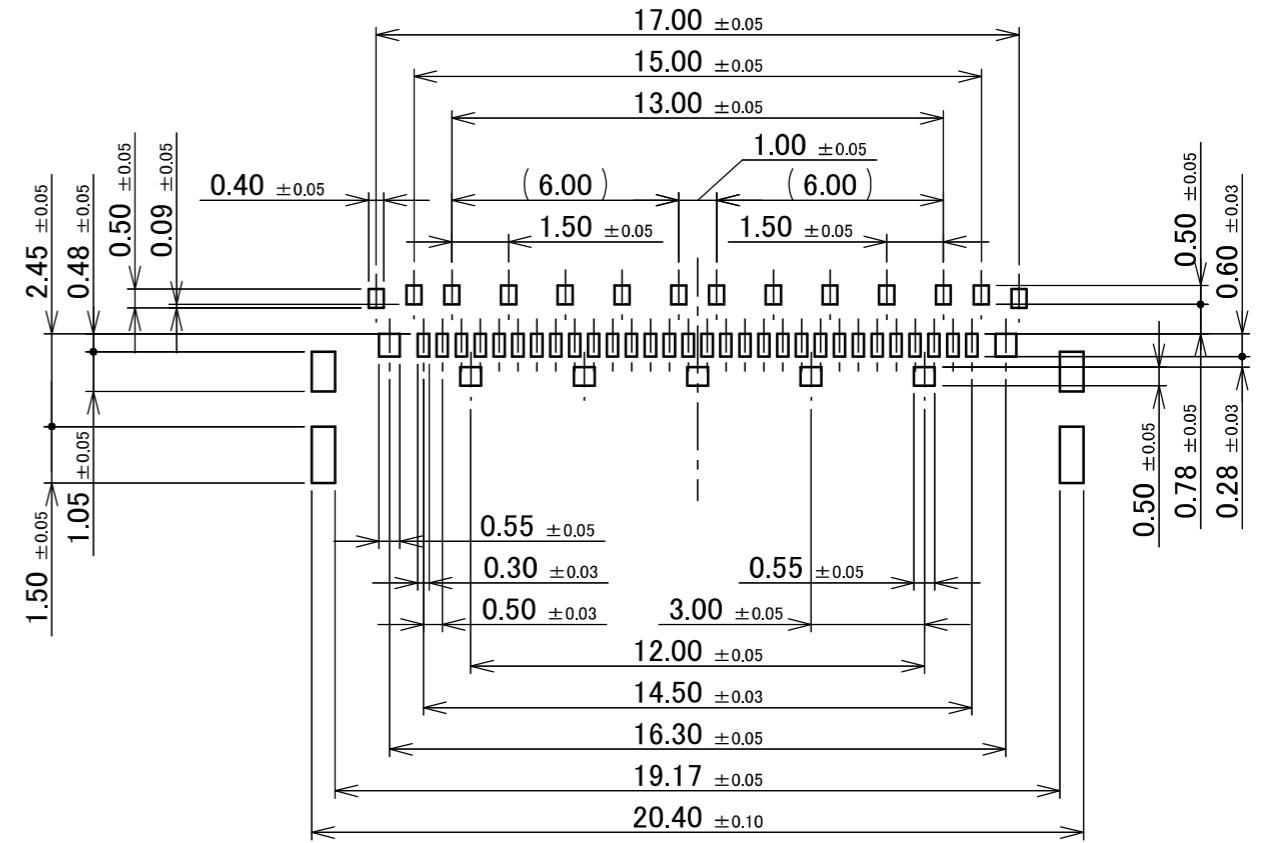

30P RECOMMENDED METAL MASK LAYOUT
METAL MASK THICKNESS : t=0.12mm

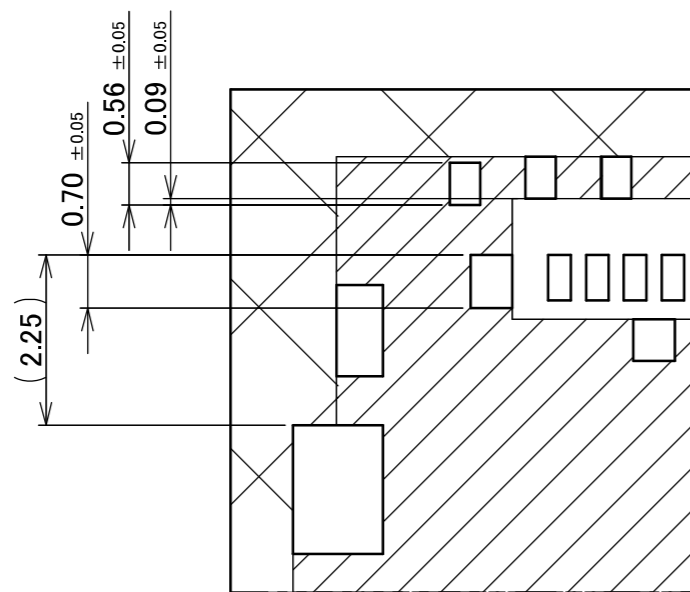

DETAIL AA
(S = 10 : 1)

NOTES.

1. SOLDER RESIST MUST BE APPLIED TO THIS AREA.
2. DO NOT MOUNT ANOTHER COMPONENT IN THIS AREA.

ANGLE	±2°	6 OVER 30 MAX.	±0.3	PROJECTION ⊕	SERIES No. R2	CUSTOMER COPY		
6 MAX.	±0.2	30 OVER 120 MAX.	±0.5					
GENERAL TOLERANCE.				TITLE CABLIN [®] -VS II RECEPTACLE ASSEMBLY	SCALE 5:1	UNIT mm		
DWG.	DATE							
CHK.								
APP.								
				DWG. No.	20849	SIZE A3	SHEET 6/9	REV. 14

PATENT REGISTERED

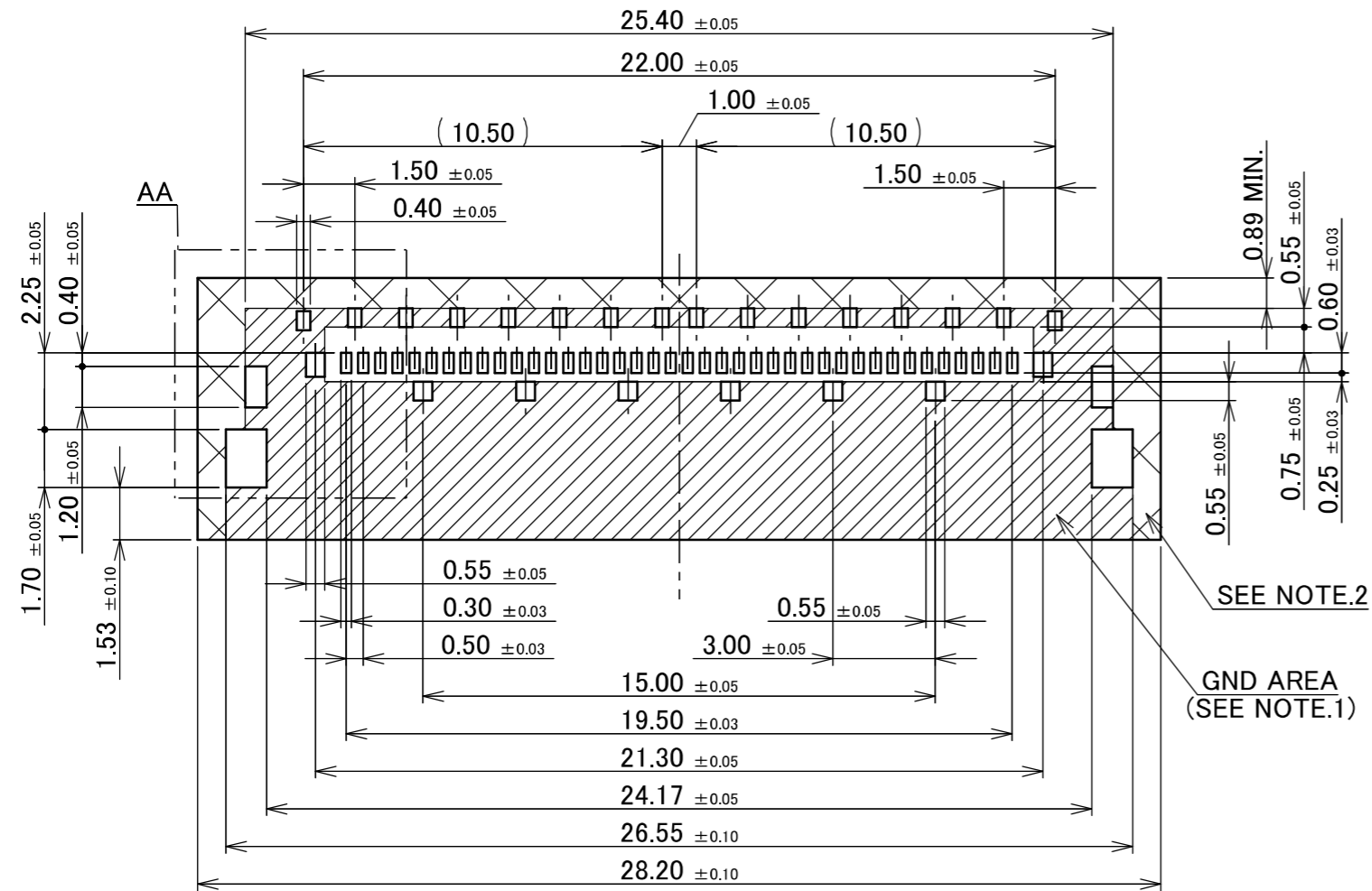

40P RECOMMENDED FOOTPRINT PATTERN LAYOUT

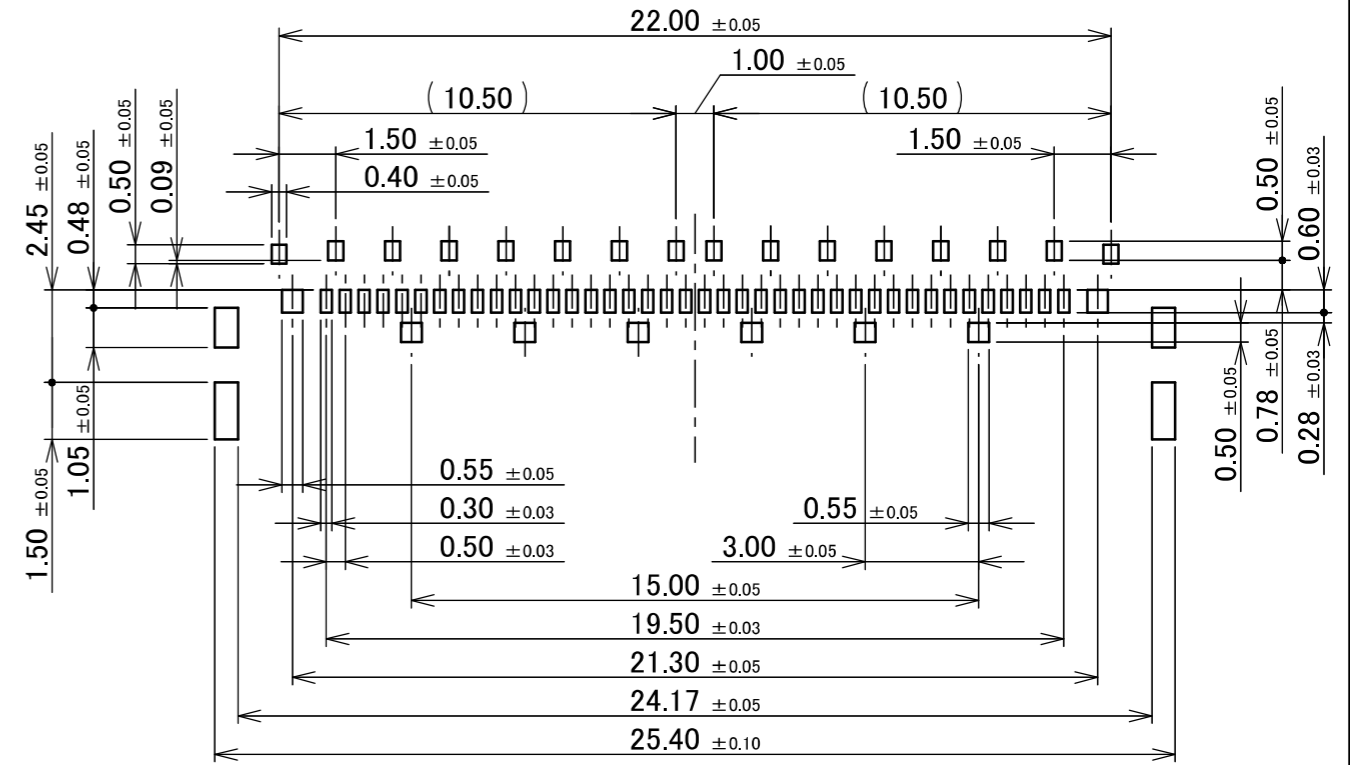

**40P RECOMMENDED METAL MASK LAYOUT
METAL MASK THICKNESS : t=0.12mm**

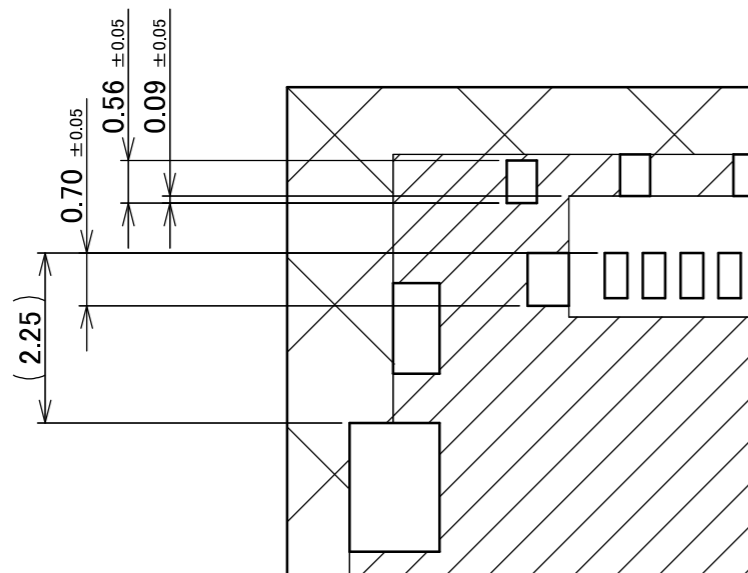

**DETAIL AA
(S = 10 : 1)**

NOTES.

1. SOLDER RESIST MUST BE APPLIED TO THIS AREA.
2. DO NOT MOUNT ANOTHER COMPONENT IN THIS AREA.

ANGLE	±2°	6 OVER 30 MAX.	±0.3	PROJECTION	SERIES No.	CUSTOMER COPY		
	6 MAX.	±0.2	30 OVER 120 MAX.	±0.5	R2	I-PEX		
GENERAL TOLERANCE.				TITLE	SCALE	I-PEX		
DWG.	DATE			CABLIN [®] -VS II RECEPTACLE ASSEMBLY	5:1			
CHK.					UNIT			
APP.					mm			
				DWG. No.	20849	SIZE	SHEET	REV.
						A3	7/9	14

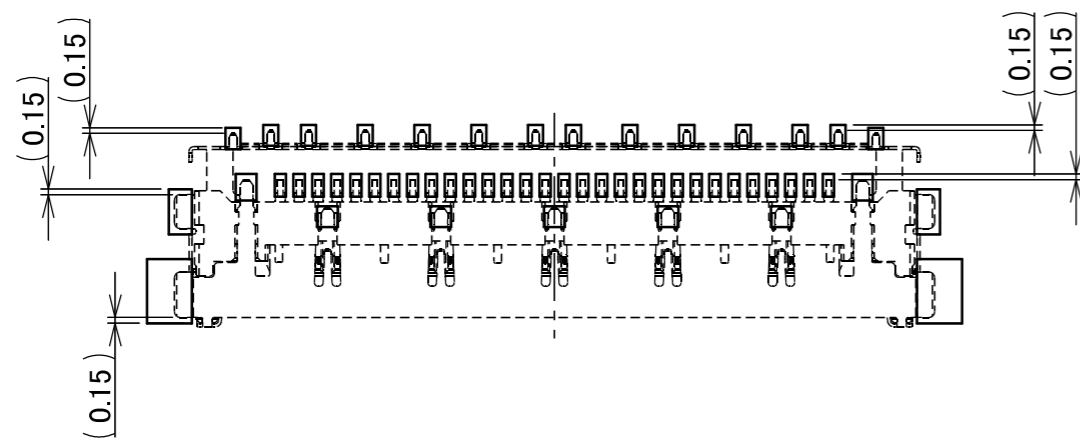

CONNECTOR ON RECOMMENDED FOOTPRINT PATTERN

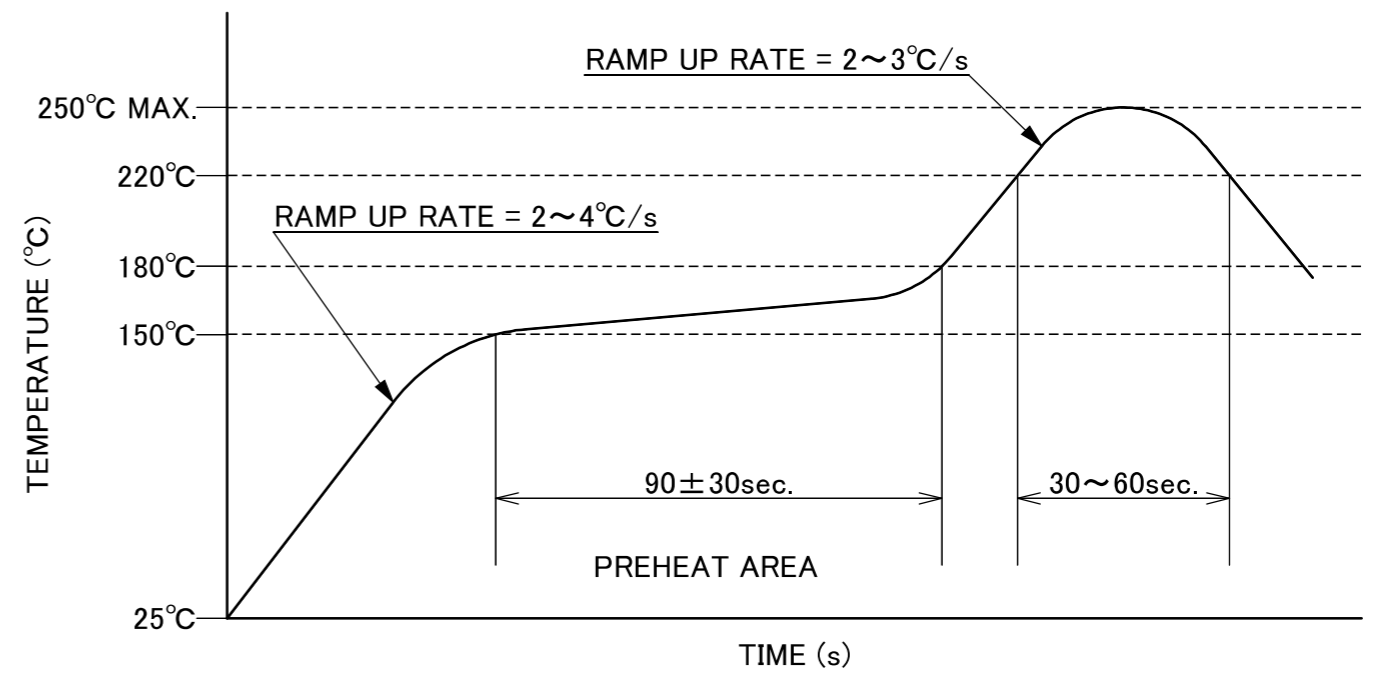

REFLOW TEMPERATURE PROFILE
SENJU METAL INDUSTRY CO., LTD. : M705-SHF(Sn96.5 Ag3.0 Cu0.5)

ANGLE	±2°	6 OVER 30 MAX.	±0.3	PROJECTION 	SERIES No. R2	CUSTOMER COPY		
6 MAX.	±0.2	30 OVER 120 MAX.	±0.5					
GENERAL TOLERANCE.				TITLE CABLIN [®] -VS II RECEPTACLE ASSEMBLY	SCALE 5:1 UNIT mm			
DWG.	DATE							
CHK.								
APP.								
				DWG. No.	20849	SIZE	SHEET	REV.
						A3	8/9	14

PART NO.	M	N	P	R	QTY. PER EMBOSS REEL (PIECES / REEL)	QTY. PER PACKING CARTON (REELS / CARTON)
20849-020E-0#	24.00	11.50	-	15.50	8000 / REEL	5 / CARTON = 40000
20849-030E-0#	32.00	14.20	28.40	20.50		4 / CARTON = 32000
20849-040E-0#	44.00	20.20	40.40	25.50		3 / CARTON = 24000

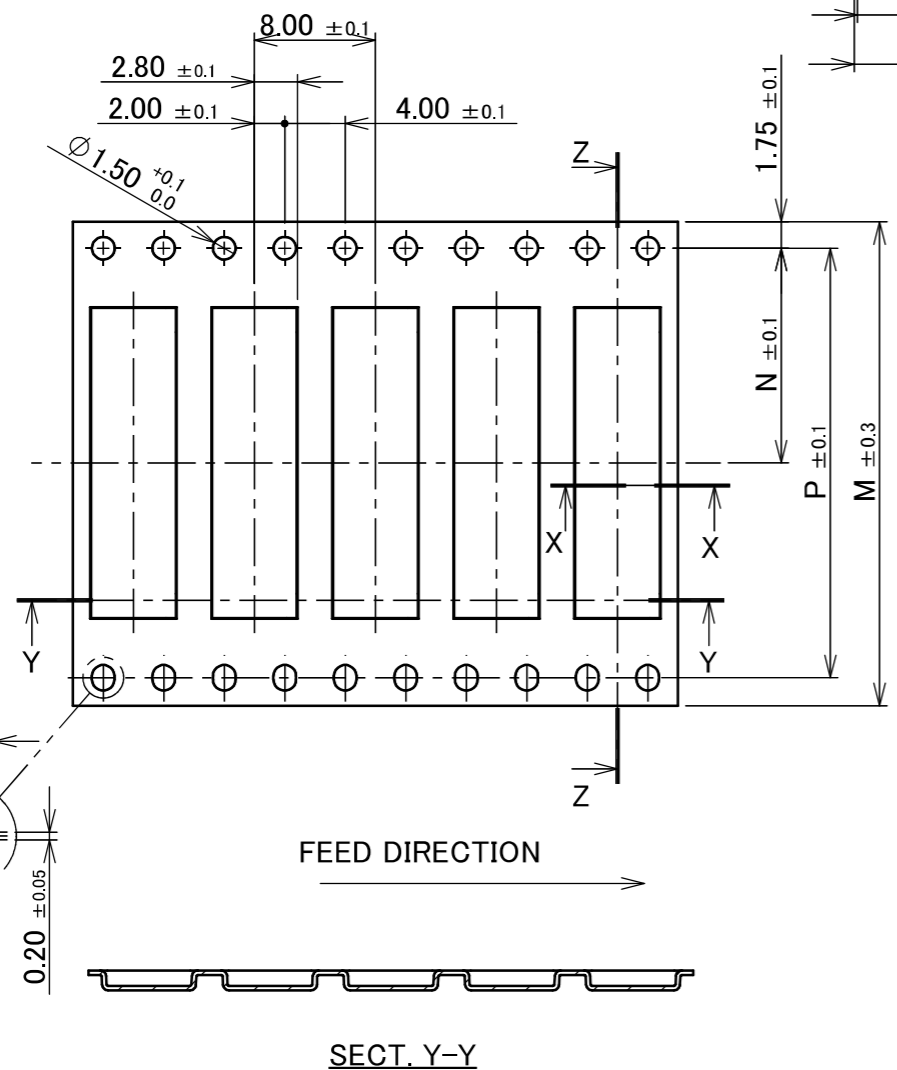
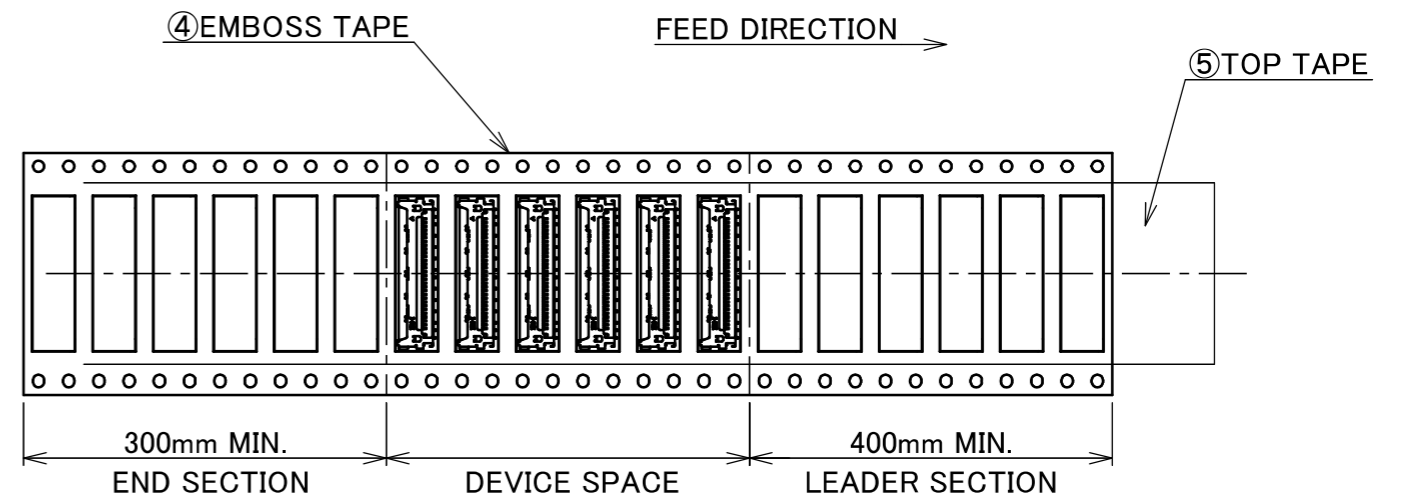
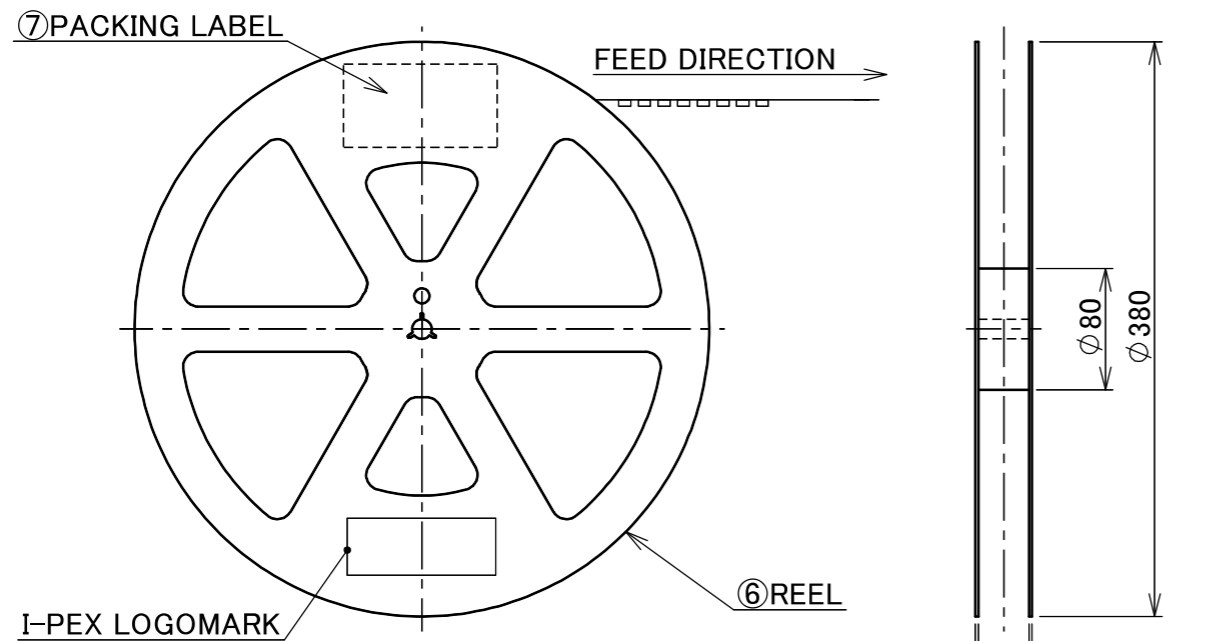

- NOTES.
- TAPING SPECIFICATION FOLLOWS JIS C 0806 (IEC 60286-3).
 - MAKE EMPTY SECTION OF LEADER AND END ON EACH END OF THE TAPE.
 - TOP TAPE SHALL NOT STICK OUT FROM EMBOSS TAPE.
 - TOP TAPE SHALL NOT COVER FEED HOLE.

NO.	DISCRIPTION	MATERIAL	FINISH , REMARKS
7	PACKING LABEL	-	-
6	REEL	PS	ANTI-STATIC TYPE BLACK
5	TOP TAPE	PET t=0.062 TRANSPARENCY	ANTI-STATIC TYPE
4	EMBOSS TAPE	PS t=0.3 TRANSPARENCY	ANTI-STATIC TYPE

ANGLE	±2°	6 OVER 30 MAX.	±0.3	PROJECTION	SERIES No.	CUSTOMER COPY		
6 MAX.	±0.2	30 OVER 120 MAX.	±0.5		R2	I-PEX SCALE 2:1 UNIT mm SIZE A3 SHEET 9/9 REV. 14		
GENERAL TOLERANCE.				TITLE				
DWG.	DATE		CABLIN® -VS II RECEPTACLE ASSEMBLY					
CHK.			DWG. No. 20849					
APP.								