

**RECOMMENDED PART No. 20532-0\*\*T-02-1**

PART No.	Pos	A	B	C	D	E	F	G	H	J	K	L
20532-030T-02-1	30	11.44	10.30	8.70	8.70	7.50	3.75	8.00	8.60	8.00	5.00	7.50
20532-034T-02-1	34	12.44	11.30	9.70	9.70	8.50	4.75	9.00	9.60	9.00	6.00	8.50
20532-040T-02-1	40	13.94	12.80	11.20	11.20	10.00	6.25	10.50	11.10	10.50	7.50	10.00
20532-050T-02-1	50	16.44	15.30	13.70	13.70	12.50	6.25	13.00	13.60	13.00	10.00	12.50

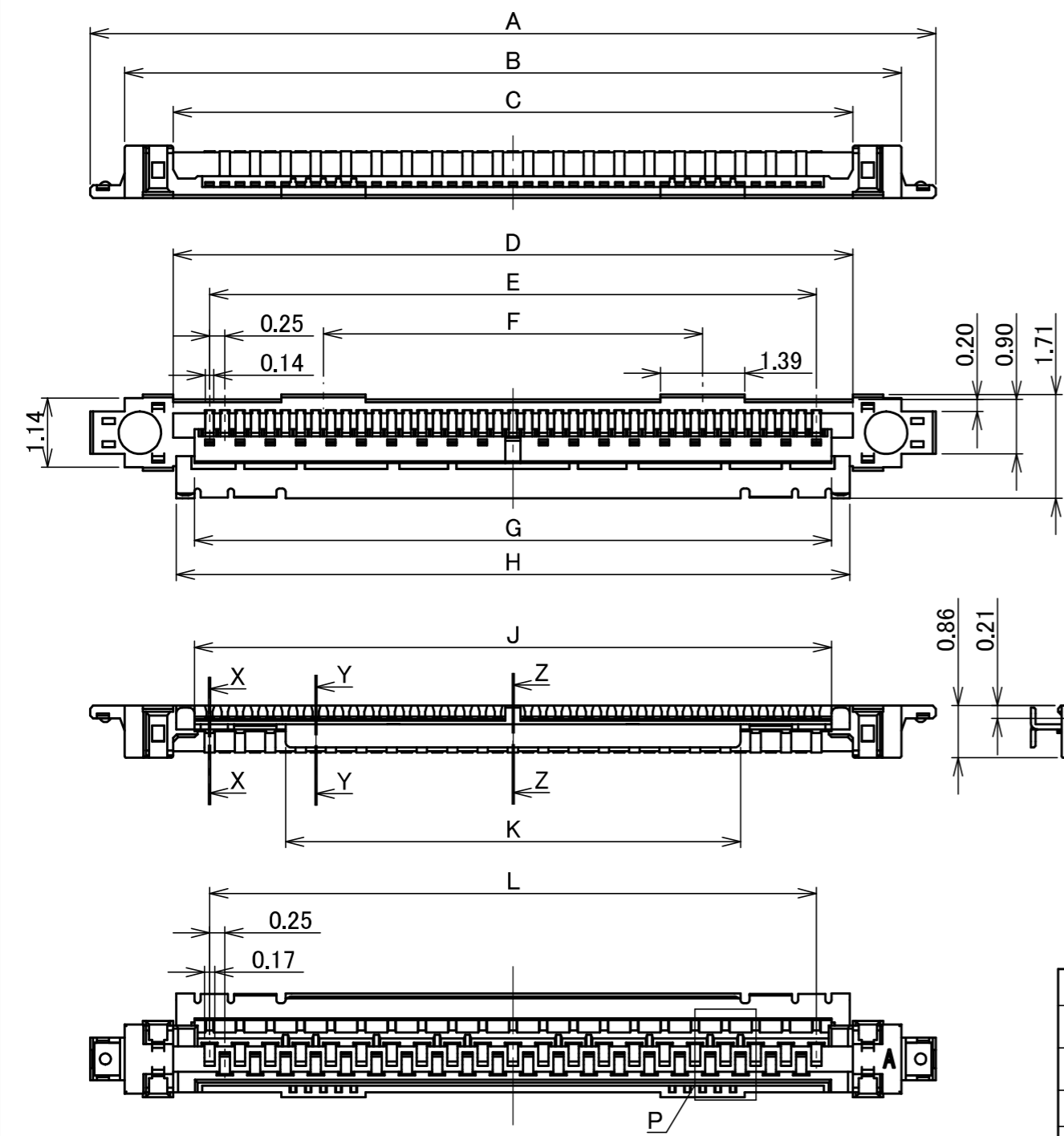

20532-0\*\*T-02-1  
Pos.

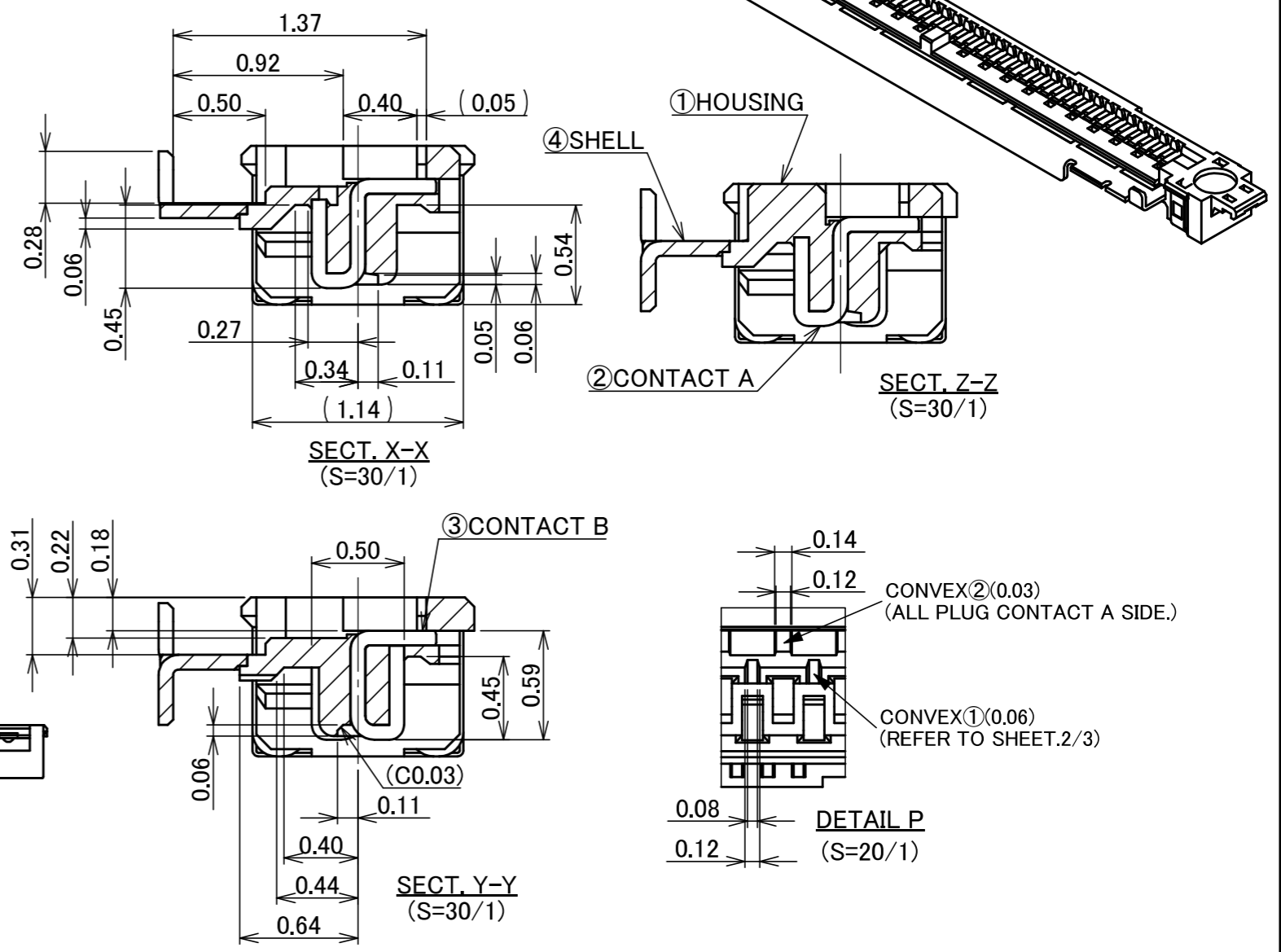
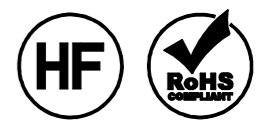
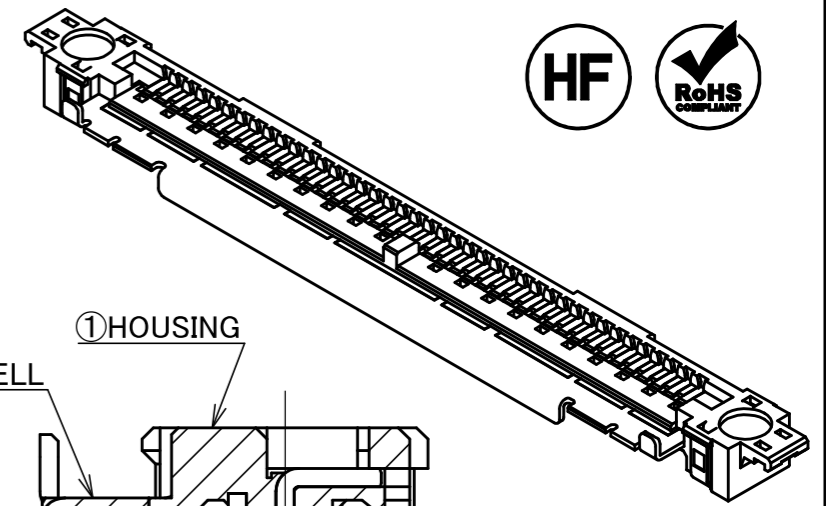

NO.	DISCRIPTION	MATERIAL	FINISH , REMARKS
4	SHELL	PHOSPHOR BRONZE	Au 0.05 μm MIN. OVER Ni 1.00 μm MIN.
3	CONTACT B	PHOSPHOR BRONZE	Au 0.1 μm MIN. OVER Ni 1.00 μm MIN.
2	CONTACT A	PHOSPHOR BRONZE	Au 0.1 μm MIN. OVER Ni 1.00 μm MIN.
1	HOUSING	LCP	UL94V-0 ,BLACK

REV.	ECN	BY	DATE	APP.	APP.	DATE	APP.	PROJECTION	SERIES No.	TITLE	SCALE	SHEET	REV.	
9	Z241678	A.K	2024/11/29	H.I	ANGLE	±2°	6 OVER 30 MAX.	±0.3	R4	CABLINER <sup>®</sup> -UX II PLUG HOUSING ASSEMBLY	10:1	1/3	9	
8	Z191209	A.K	2019/09/12	H.I	6 MAX.	±0.2	30 OVER 120 MAX.	±0.5						
7	Z180877	A.K	2018/09/24	H.I	GENERAL TOLERANCE.			E.Kawabe	20532	A3	1/3	9		
6	Z170849	R.H	2017/08/21	M.T	DWG.	M.Takemoto	DATE						2010/07/08	
5	Z150166	S.T	2015/02/16	Tom	CHK.									
4	Z140256	D.S	2014/03/19	K.N	APP.									
REVISION RECORD					E.Kawabe			20532		A3		1/3		9

SHAPE OF 30P  
9 POSITIONS IN TOTAL.  
(INCLDING CENTER)

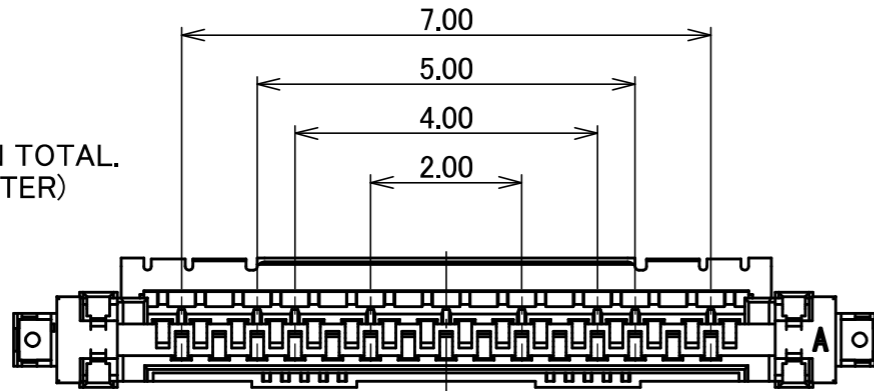

SHAPE OF 34P  
9 POSITIONS IN TOTAL.  
(INCLDING CENTER)

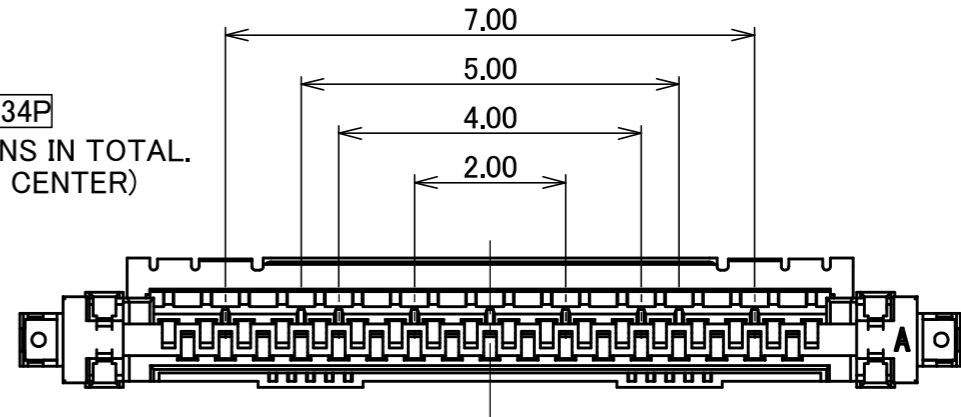

SHAPE OF 40P  
10 POSITIONS IN TOTAL.

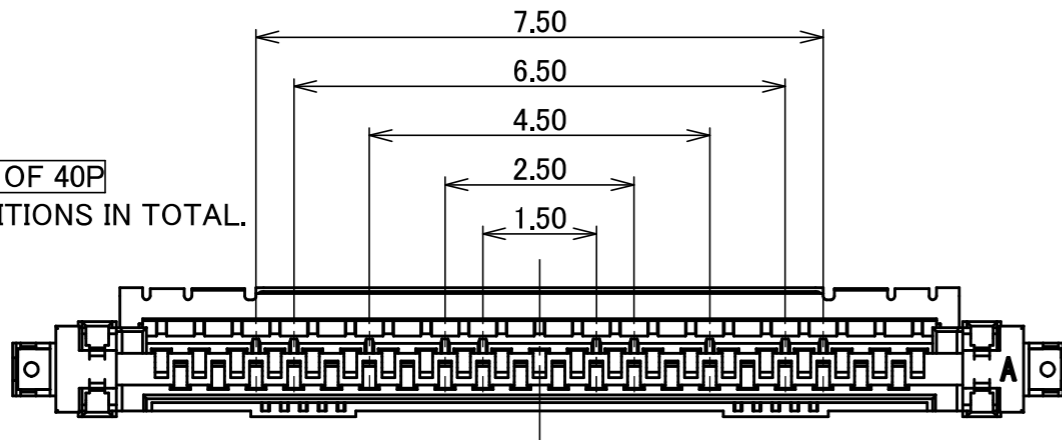

SHAPE OF 50P  
13 POSITIONS IN TOTAL.  
(INCLDING CENTER)

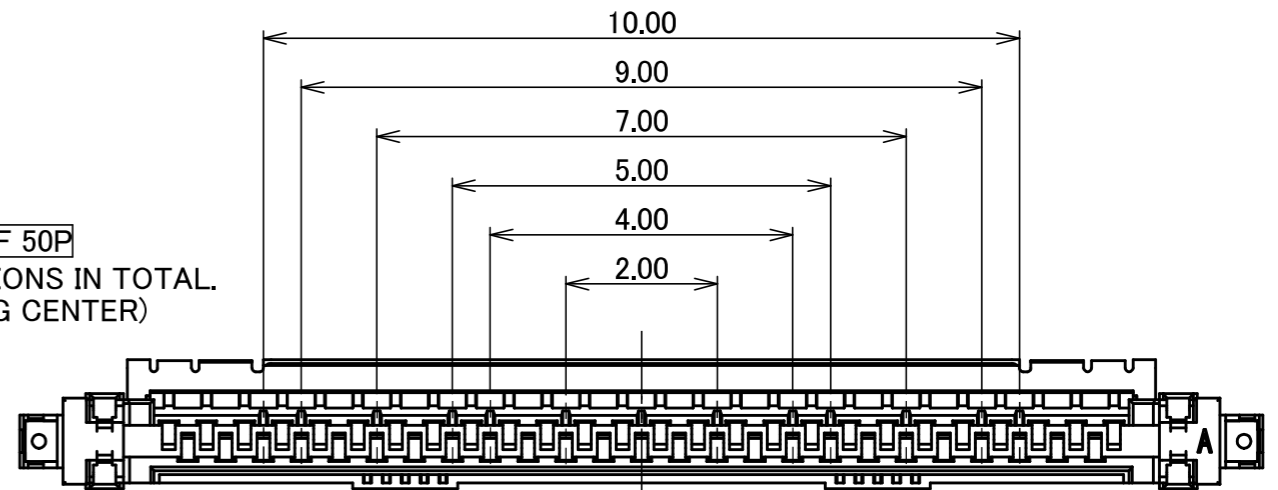

POSITION OF CONVEX①

ANGLE	±2°	6 OVER 30 MAX.	±0.3	PROJECTION	SERIES No.	CUSTOMER COPY							
	6 MAX.	±0.2	30 OVER 120 MAX.	±0.5	R4								
GENERAL TOLERANCE.					TITLE	SCALE	UNIT						
DWG.	DATE							CABLINÉ® -UX II PLUG HOUSING ASSEMBLY	10:1	mm			
CHK.											A3	SHEET	REV.
APP.													

PART NO.	QTY. IN DITCH (PIECES / DITCH)	QTY. IN TRAY (PIECES / TRAY)	QTY. PER SHIPPING CARTON (TRAYS / S CARTON)	QTY. PER PACKING CARTON (S CARTON / P CARTON)	PACKING STANDARD
20532-0**T-02-1	1	200	20 / S CARTON = 4000	4 / CARTON = 16000	300-873

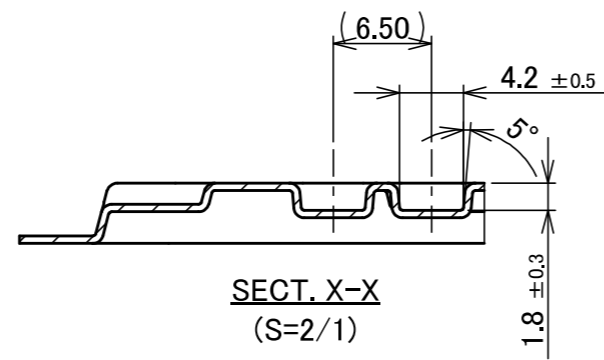
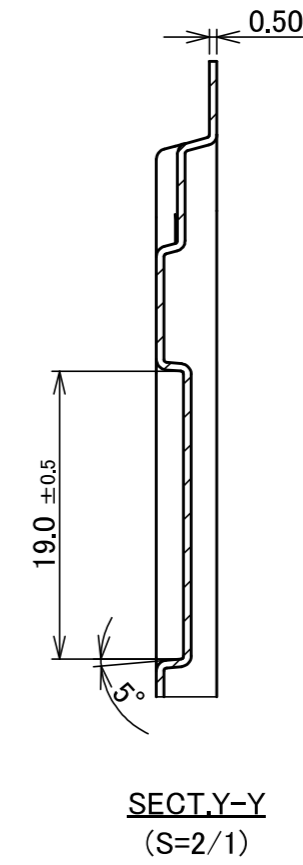
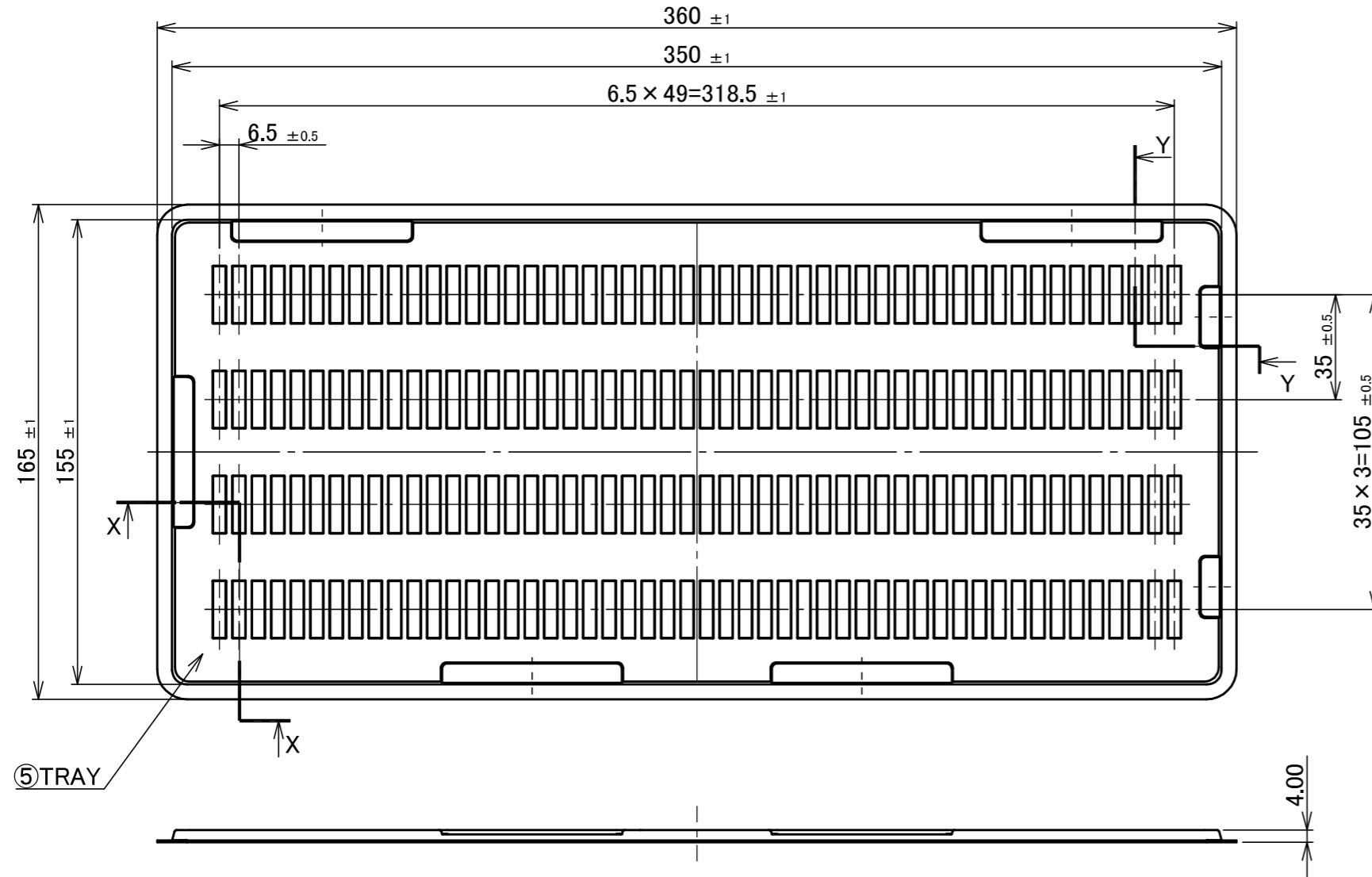

5	TRAY	PS	ANTI-STATIC TYPE
NO.	DISCRIPTION	MATERIAL	FINISH , REMARKS

ANGLE	±2°	6 OVER 30 MAX.	±0.3	PROJECTION ⊕	SERIES No. R4	CUSTOMER COPY		
6 MAX.	±0.2	30 OVER 120 MAX.	±0.5					
GENERAL TOLERANCE.				TITLE		SCALE	<b>I-PEX</b>	
DWG.	DATE			CABLIN® -UX II PLUG HOUSING ASSEMBLY		1:2		
CHK.						UNIT		
APP.				DWG. No. 20532		mm		
						SIZE	SHEET	REV.
						A3	3/3	9