

Recommended P/N 20879-0\*\*E-01

PART NO.	Pos.	A	B	C	D	E	F	G	H
20879-030E-#1	30	15.27	13.01	11.60	9.60	12.07	12.88	15.27	13.65
20879-040E-#1	40	19.27	17.01	15.60	14.40	16.07	16.88	19.27	17.65
20879-050E-#1	50	23.27	21.01	19.60	17.60	20.07	20.88	23.27	21.65
20879-060E-#1	60	27.27	25.01	23.60	21.60	24.07	24.88	27.27	25.65

P/N : 20879-0\*\*E-##

1 : NARROW GROUND PIN TYPE  
 2 : WIDER GROUND PIN TYPE  
 SEE TABLE.1

#1 TYPE



Halogen Free RoHS Compliant

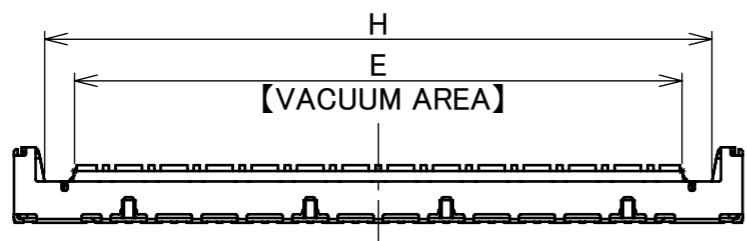
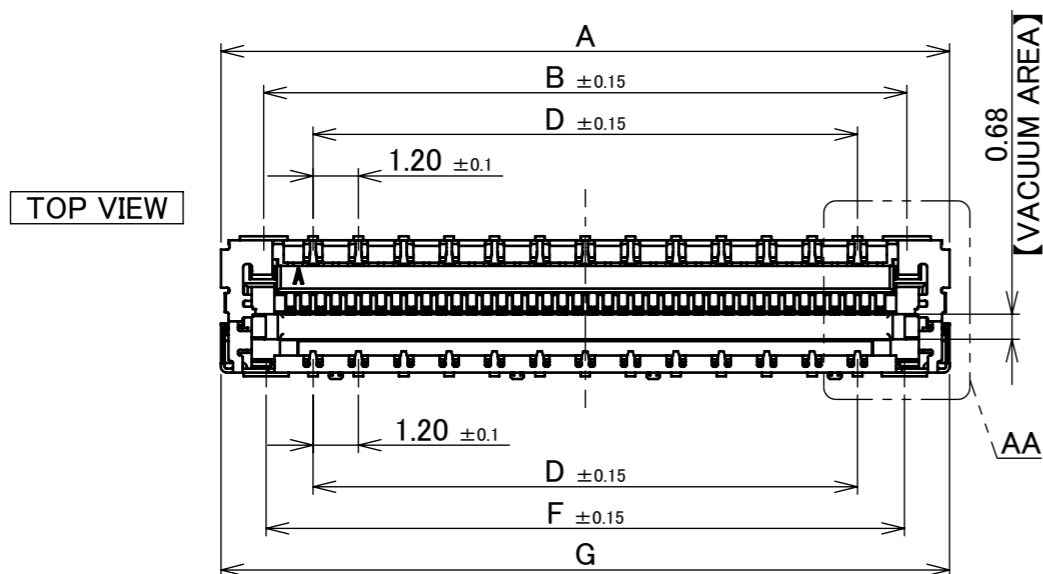

BOTTOM VIEW

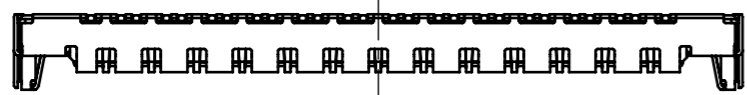
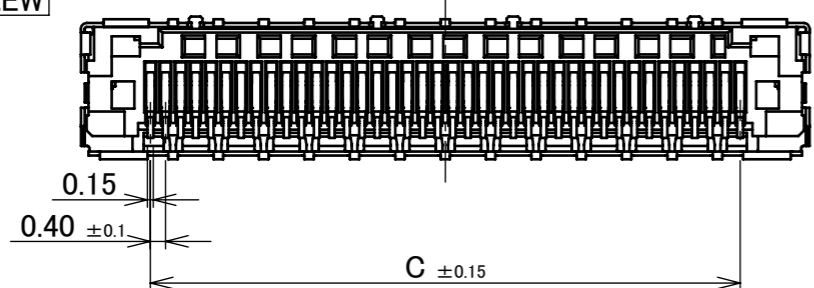

**PATENT PENDING**

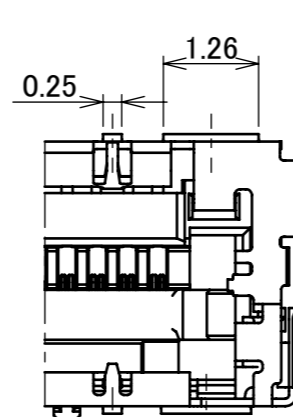

DETAIL AA (S=10:1)

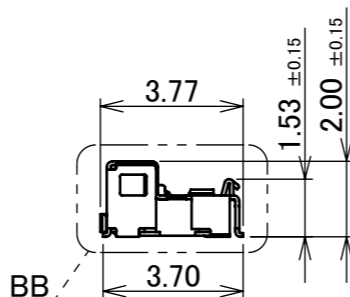

DETAIL BB (S=20:1)

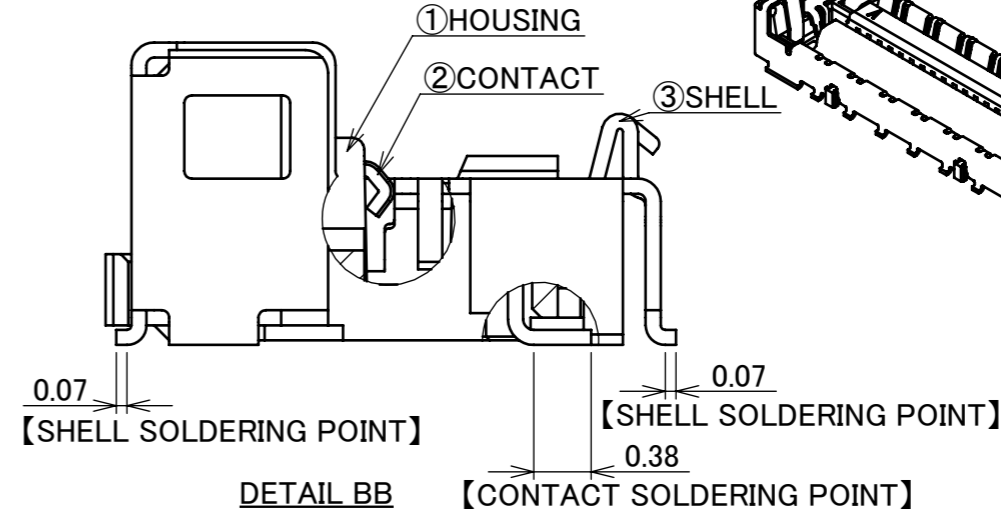

RECEPTACLE P/N : 20879-0\*\*E-#1

PLUG. P/N : 20877-0\*\*T-0#

MATING CONDITION TABLE.1

PART NO.	CONTACT FINISH
20879-0**E-01	ALL OVER Ni 1.00 μm MIN. CONTACT & SOLDERING AREA : Au 0.03 μm MIN.
20879-0**E-11	ALL OVER Ni 1.27 μm MIN. CONTACT AREA : Au 0.254 μm MIN. SOLDERING AREA : Au 0.03 μm MIN.

NO.	DISCRIPTION	MATERIAL	FINISH , REMARKS
3	SHELL	PHOSPHOR BRONZE	ALL OVER : Ni 1.00 μm MIN. SOLDERING AREA : Au 0.02 μm MIN.
2	CONTACT	CORSON ALLOY	SEE TABLE.1
1	HOUSING	LCP	UL94V-0, BLACK

REV.	ECN	BY	DATE	APP.	APP.	PROJECTION	SERIES No.	TITLE	SCALE	SHEET	REV.
14	Z241484	T.Ono	Oct./23/'24	T.M	ANGLE ±2°	6 OVER 30 MAX. ±0.3	R5	CABLINER <sup>®</sup> -UM RECEPTACLE ASSEMBLY	5:1	1/17	14
13	Z240414	T.Ono	Apr./04/'24	T.M	6 MAX. ±0.2	30 OVER 120 MAX. ±0.5	R5		UNIT		
12	Z240035	R.M	Jan./11/'24	T.M	GENERAL TOLERANCE.			mm			
11	Z231031	H.U	Sept./13/'23	T.M	DWG. T.Masunaga	DATE 2019/01/10		SIZE			
10	Z230612	R.M	May./26/'23	T.M	CHK. -			A3			
9	Z230295	Y.I	Mar./15/'23	M.T	APP. H.Ikari						
REVISION RECORD					H.Ikari		DWG. No. 20879				

Recommended P/N 20879-0\*\*E-01

PART NO.	Pos.	A	D	G
20879-030E-#1	30	15.27	9.60	15.27
20879-040E-#1	40	19.27	14.40	19.27
20879-050E-#1	50	23.27	17.60	23.27
20879-060E-#1	60	27.27	21.60	27.27



Halogen Free



RoHS Compliant

TOP VIEW

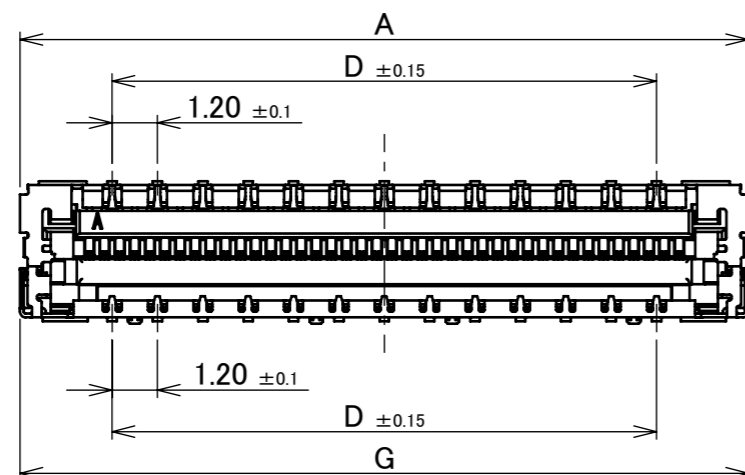

BOTTOM VIEW

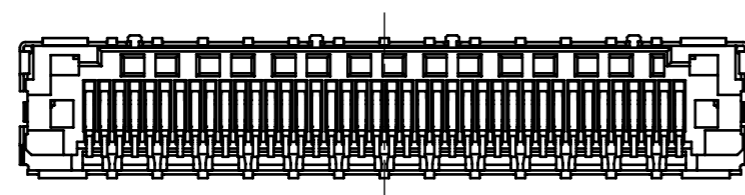

30P, 40P, 60P

TOP VIEW

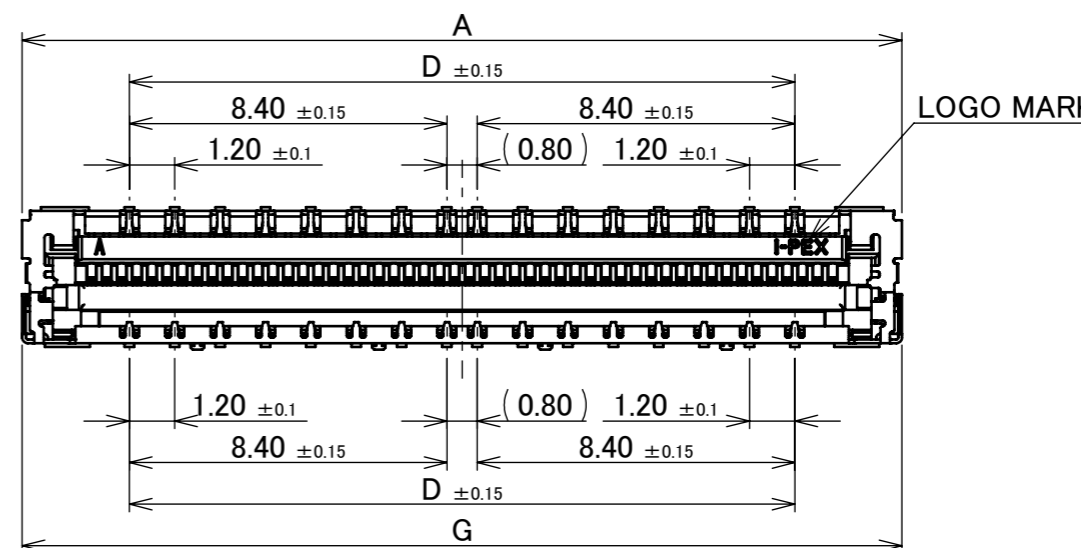

BOTTOM VIEW

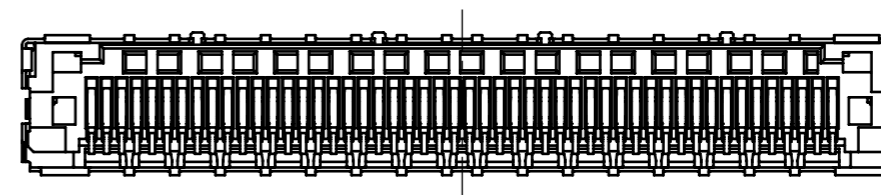

50P

**PATENT PENDING**

ANGLE	±2°	6 OVER 30 MAX.	±0.3	PROJECTION ⊕	SERIES No. R5	CUSTOMER COPY			
6 MAX.	±0.2	30 OVER 120 MAX.	±0.5						
GENERAL TOLERANCE.				TITLE CABLINÉ® -UM RECEPTACLE ASSEMBLY	SCALE	<b>I-PEX</b>			
DWG.	DATE				5:1				
CHK.					UNIT				mm
APP.					SIZE				SHEET
				DWG. No.	20879	A3	2/17	14	

Recommended P/N 20879-0\*\*E-01

PART NO.	Pos.	A	C	E	G	H	J	K	L	M	N
20879-030E-02	30	15.27	11.60	12.07	15.27	13.65	14.87	4.00	-	7.09	14.69
20879-040E-02	40	19.27	15.60	16.07	19.27	17.65	18.87	8.00	4.00	6.70	18.69
20879-060E-02	60	27.27	23.60	24.07	27.27	25.65	26.87	17.60	11.20	10.70	26.69

02 TYPE



Halogen Free



RoHS Compliant

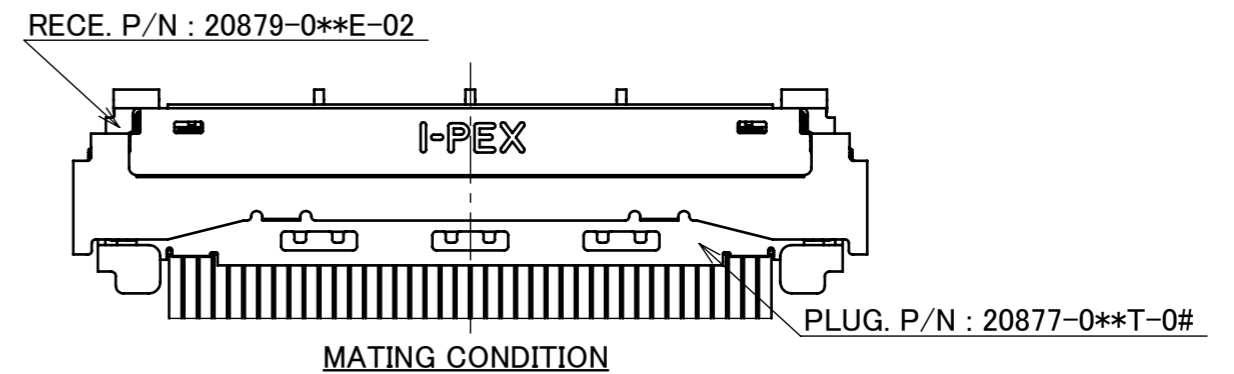
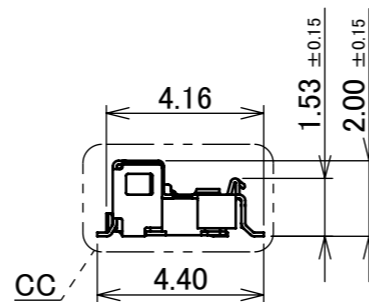
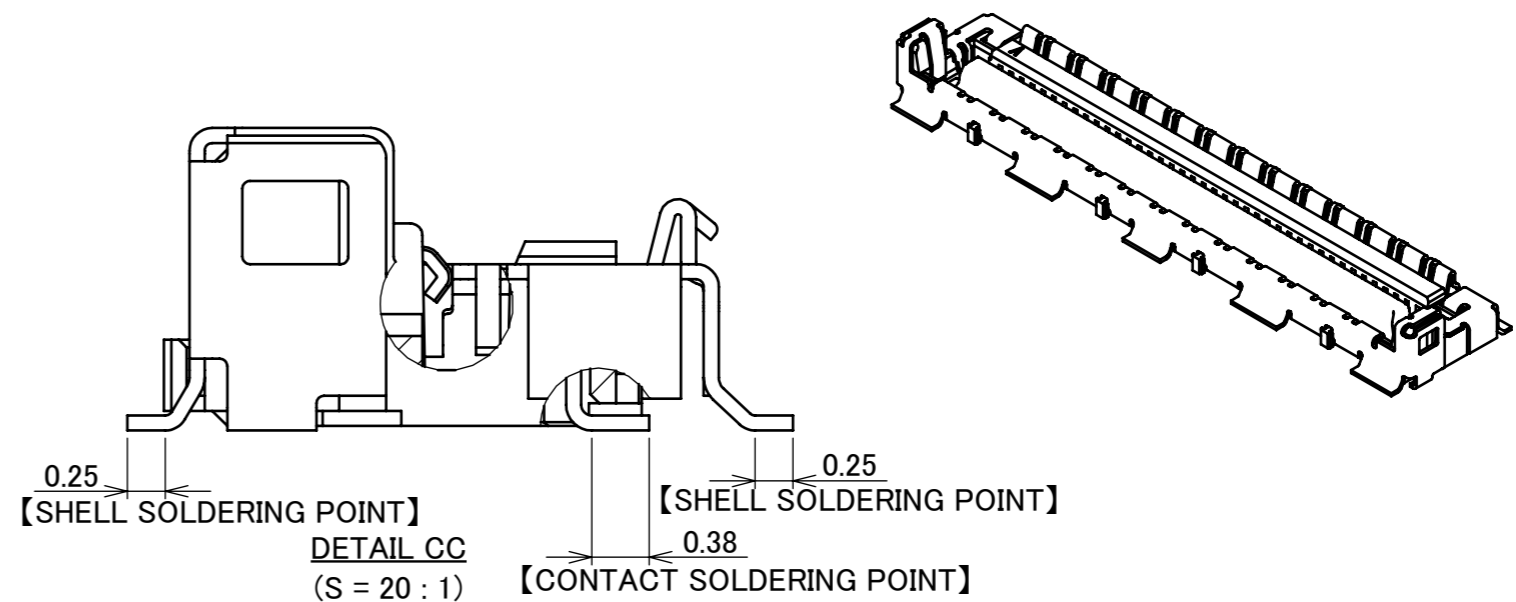
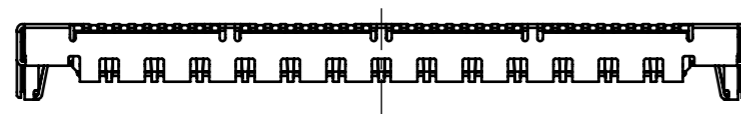
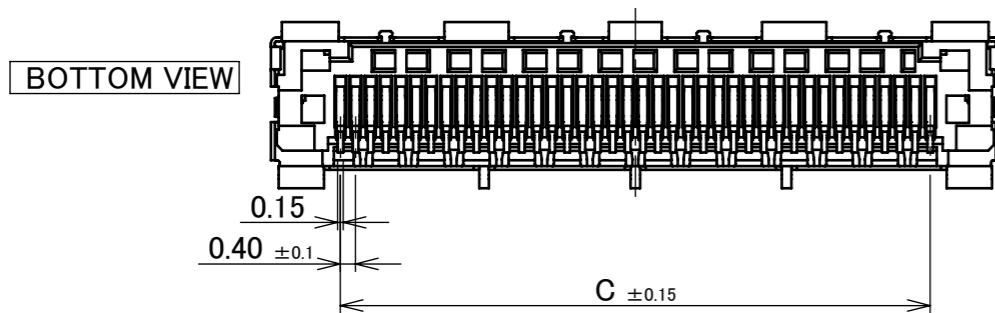
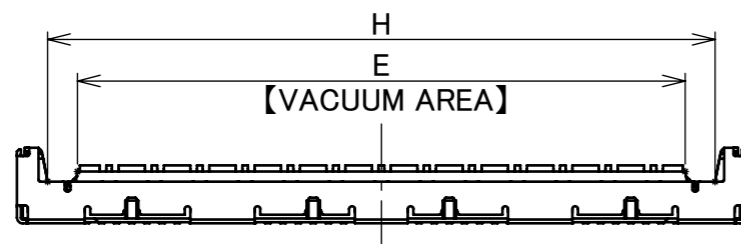
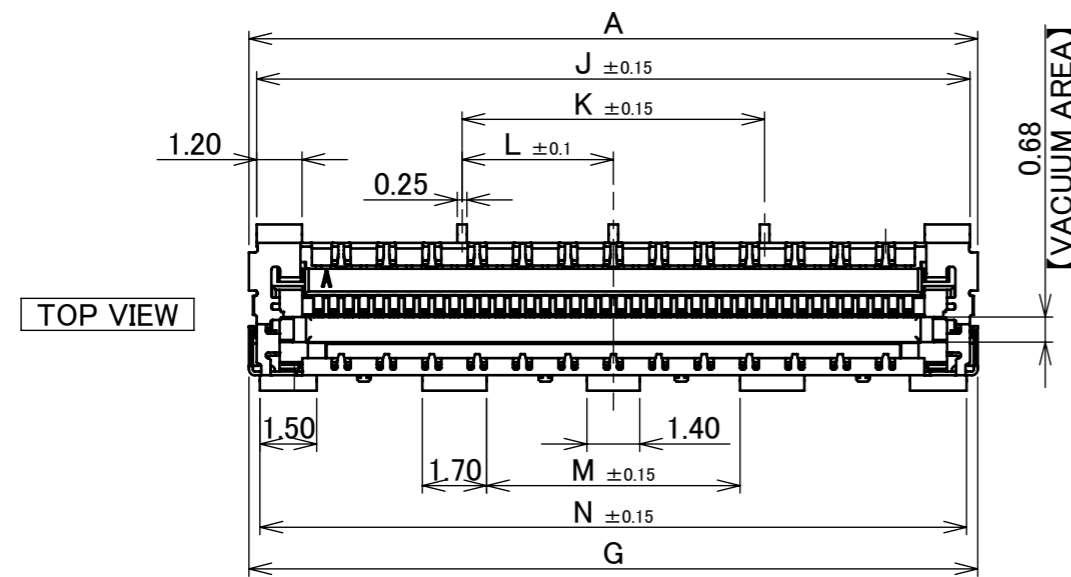

**PATENT PENDING**

ANGLE	±2°	6 OVER 30 MAX.	±0.3	PROJECTION ⊕	SERIES No. R5	CUSTOMER COPY			
6 MAX.	±0.2	30 OVER 120 MAX.	±0.5						
GENERAL TOLERANCE.				TITLE CABLINÉ® -UM RECEPTACLE ASSEMBLY		SCALE 5:1	<b>I-PEX</b>		
DWG.	DATE			DWG. No. 20879		UNIT mm			
CHK.									
APP.									

Recommended P/N 20879-0\*\*E-01

PART NO.	Pos.	A	C	E	G	H	J	K	L	M	N	AD
20879-030E-02	30	15.27	11.60	12.07	15.27	13.65	14.87	4.00	-	7.09	14.69	-
20879-040E-02	40	19.27	15.60	16.07	19.27	17.65	18.87	8.00	4.00	6.70	18.69	-
20879-060E-02	60	27.27	23.60	24.07	27.27	25.65	26.87	17.60	11.20	10.70	26.69	3.20

02 TYPE



Halogen Free



RoHS Compliant

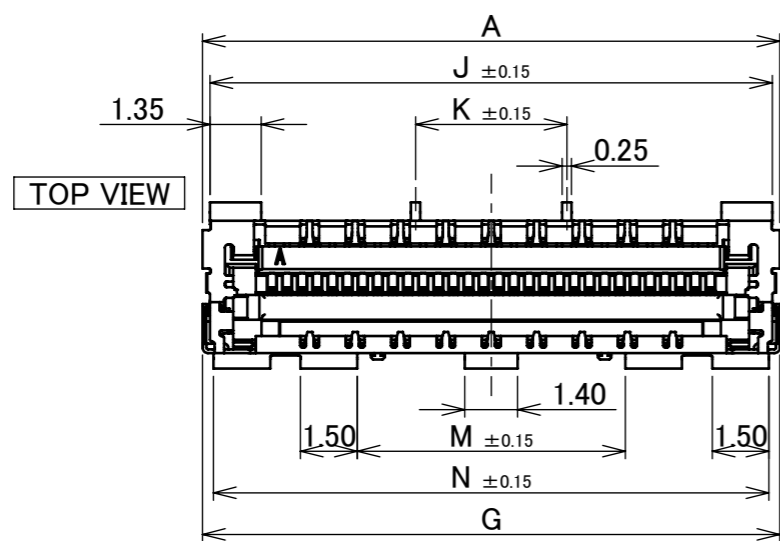

30P SHAPE  
(S = 5 : 1)

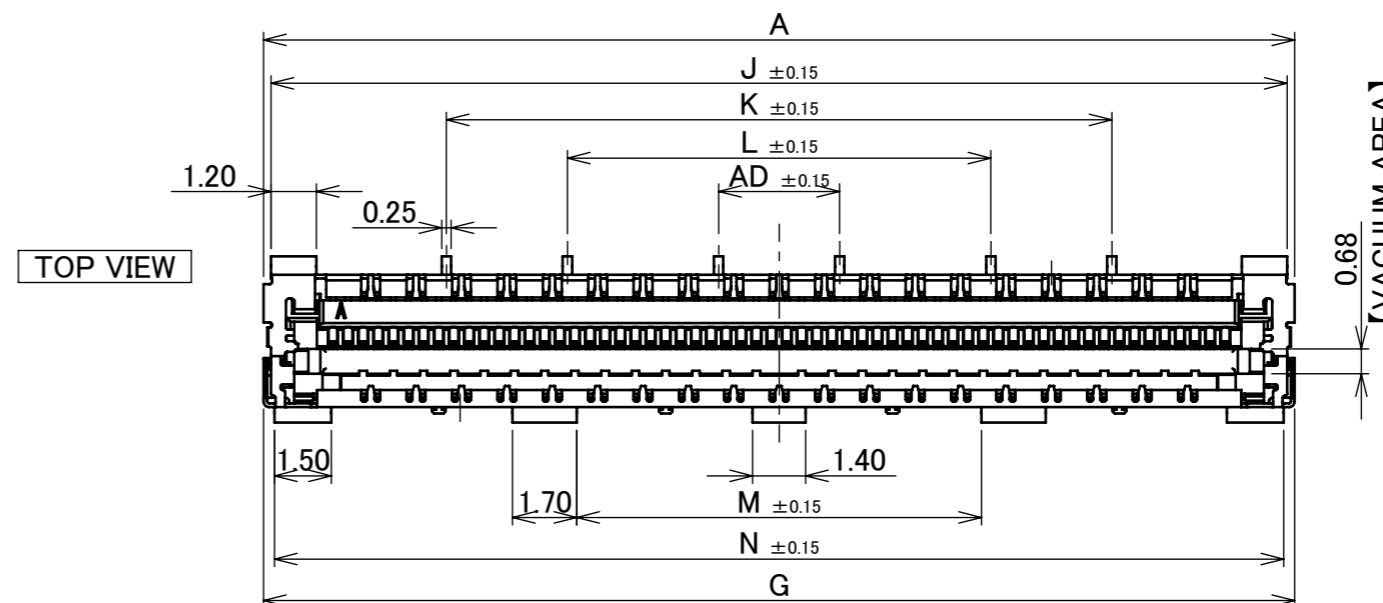

60P SHAPE  
(S = 5 : 1)

**PATENT PENDING**

ANGLE	±2°	6 OVER 30 MAX.	±0.3	PROJECTION ⊕	SERIES No. R5	CUSTOMER COPY		
6 MAX.	±0.2	30 OVER 120 MAX.	±0.5					
GENERAL TOLERANCE.				TITLE CABLIN <sup>®</sup> -UM RECEPTACLE ASSEMBLY	SCALE 5:1 UNIT mm	I-PEX		
DWG.	DATE							
CHK.								
APP.								
				DWG. No.	20879	SIZE A3	SHEET 4/17	REV. 14

ITEMS	SPECIFICATION
APPLICABLE CABLE	MICRO-COAXIAL CABLE : AWG# 44 , 42 , 40 , 38 , 36 DISCRETE WIRE : AWG# 36 , 34 TWINAX CABLE : AWG# 40 , 42
RATING VOLTAGE	100V AC (PER CONTACT PIN) ※THIS IS THE RATED VOLTAGE OF THE CONNECTOR. PLEASE NOTE THAT THE RATED VOLTAGE MAY VARY IN THE HARNESS DEPENDING ON THE CABLES USED.
RATING AMPERAGE (FOR CONTACT)	0.15A AC/DC [AWG#44] PER CONTACT PIN/UP TO 60 CONTACTS 0.24A AC/DC [AWG#42] PER CONTACT PIN/UP TO 49 CONTACTS 0.3A AC/DC [AWG#40] PER CONTACT PIN/UP TO 38 CONTACTS 0.5A AC/DC [AWG#38] PER CONTACT PIN/UP TO 19 CONTACTS 0.8A AC/DC [AWG#36] PER CONTACT PIN/UP TO 12 CONTACTS 1.0A AC/DC [AWG#34] PER CONTACT PIN/UP TO 10 CONTACTS ※TESTING BY A REAL MACHINE IS RECOMMENDED BECAUSE TEMPERATURE RISE MAY AFFECTED BY ACTUAL SITUATION.
OPERATING TEMPERATURE	233~378K(-40°C~+105°C)
OPERATING HUMIDITY	85% MAX.
CONTACT RESISTANCE	INITIAL : 180mohm MAX.(AWG#34) / AFTER TEST : $\triangleleft$ 40mohm MAX. 275mohm MAX.(AWG#36) 360mohm MAX.(AWG#38) 600mohm MAX.(AWG#40) 700mohm MAX.(AWG#42) 1080mohm MAX.(AWG#44)
GROUND SHELL RESISTANCE	INITIAL : 50mohm MAX. / AFTER TEST : $\triangleleft$ 40mohm MAX.
INSULATION RESISTANCE	INITIAL : 1000Mohm MIN. / AFTER TEST : 500Mohm MIN.
DIELECTRIC WITHSTANDING VOLTAGE	AC250V 1min
DURABILITY	30 CYCLES
MATING FORCE (INITIAL / AFTER TEST)	30P : 34.00N MAX. 50P : 46.00N MAX. 40P : 40.00N MAX. 60P : 52.00N MAX.
UNMATING FORCE (INITIAL / AFTER TEST)	30P : 3.0N MIN. 50P : 5.0N MIN. 40P : 4.0N MIN. 60P : 6.0N MIN.
CABLE RETENTION FORCE	30P : 14.70N MIN. 50P : 24.50N MIN. 40P : 19.60N MIN. 60P : 29.40N MIN.
COPLANARITY	0.10 MAX.
PRODUCT SPECIFICATION	PRS-2514
TEST REPORT	TR-18067 (PLUG:20877-0**T-0#, RECEPTACLE:20879-0**E-01) TR-18088 (PLUG:20877-0**T-0#, RECEPTACLE:20879-0**E-02) TR-24001 (PLUG:20877-0**T-0#, RECEPTACLE:20879-0**E-11) TR-24002 (PLUG:20877-0**T-1#, RECEPTACLE:20879-0**E-01) TR-24003 (PLUG:20877-0**T-1#, RECEPTACLE:20879-0**E-02) TR-24004 (PLUG:20877-0**T-1#, RECEPTACLE:20879-0**E-11)
PACKING STANDARD	PST-18043
INSTRUCTION MANUAL	HIM-18033
APPEARANCE CRITERIA No.	QLS-A***

ANGLE	$\pm 2^\circ$	6 OVER 30 MAX.	$\pm 0.3$	PROJECTION 	SERIES No. R5	CUSTOMER COPY				
	6 MAX.	$\pm 0.2$	30 OVER 120 MAX.			$\pm 0.5$	TITLE CABLIN <sup>®</sup> -UM RECEPTACLE ASSEMBLY	SCALE	<b>I-PEX</b>	
GENERAL TOLERANCE.				DWG. No.	20879	UNIT	mm	SIZE		
DWG.	DATE						A3	5/17	14	
CHK.										
APP.										

PART No.	Pos.	B	C	D	F	P	Q	R	S	T
20879-030E-#1	30	13.01	11.60	9.60	12.88	15.17	12.00	15.07	19.00	12.50
20879-040E-#1	40	17.01	15.60	14.40	16.88	19.17	16.00	19.07	23.00	16.50
20879-060E-#1	60	25.01	23.60	21.60	24.88	27.17	24.00	27.07	31.00	24.50

**#1 TYPE**

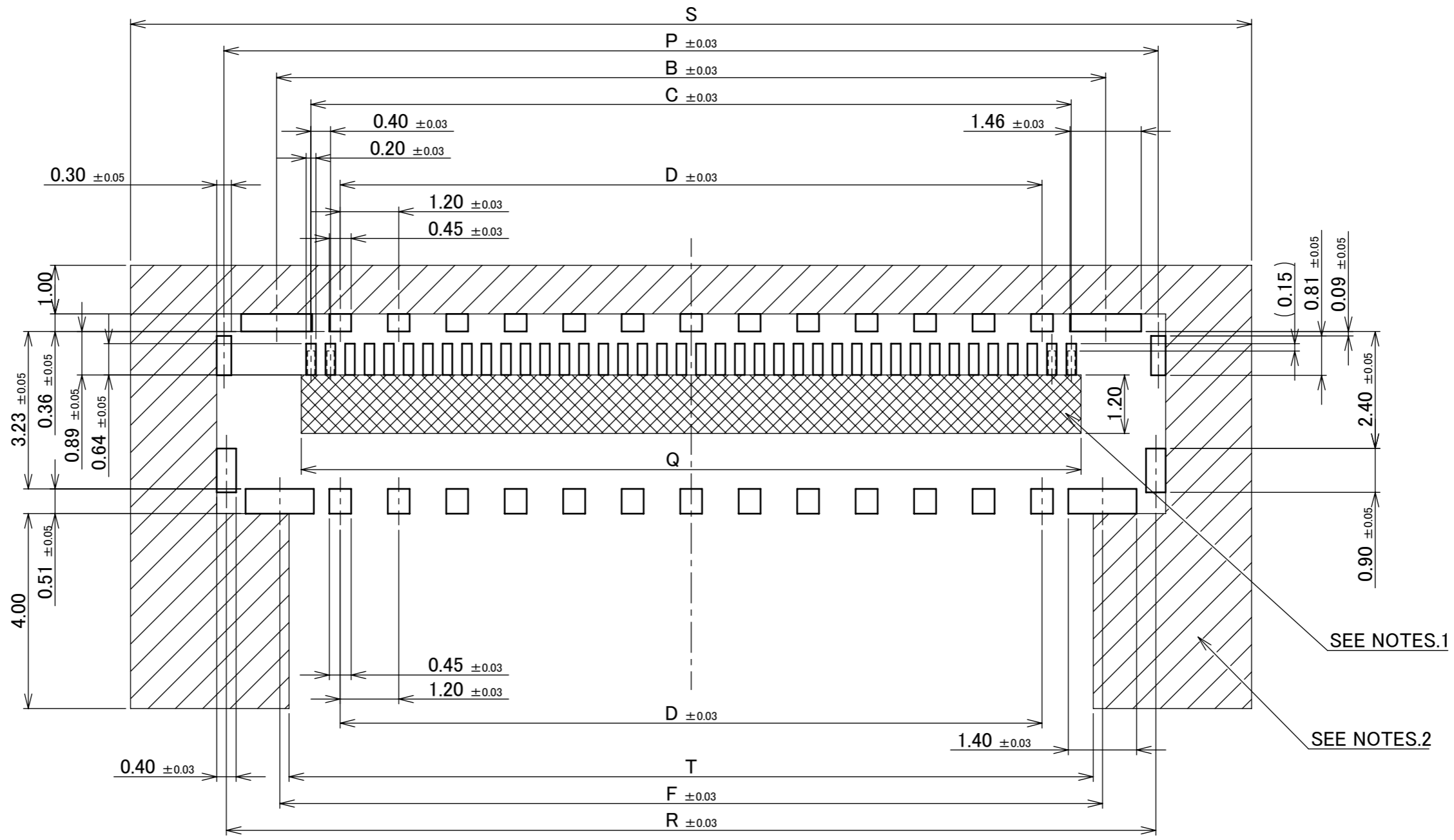

#1 TYPE 30P, 40P, 60P RECOMMENDED PCB LAYOUT  
(S = 10 : 1)

- NOTES.  
 1. SOLDER RESIST MUST BE APPLIED TO THIS AREA.  
 2. DO NOT MOUNT ANOTHER COMPONENT IN THIS AREA.

**PATENT PENDING**

ANGLE	±2°	6 OVER 30 MAX.	±0.3	PROJECTION ⊕	SERIES No. R5	CUSTOMER COPY		
6 MAX.	±0.2	30 OVER 120 MAX.	±0.5					
GENERAL TOLERANCE.				TITLE CABLINER <sup>®</sup> -UM RECEPTACLE ASSEMBLY	SCALE 10:1	<b>I-PEX</b>		
DWG.	DATE							
CHK.								
APP.								
				DWG. No.	20879	SIZE A3	SHEET 6/17	REV. 14

PART No.	Pos.	B	C	D	F	P	Q	R	S	T
20879-050E-#1	50	21.01	19.60	17.60	20.88	23.17	20.00	23.07	27.00	20.50

**#1 TYPE**

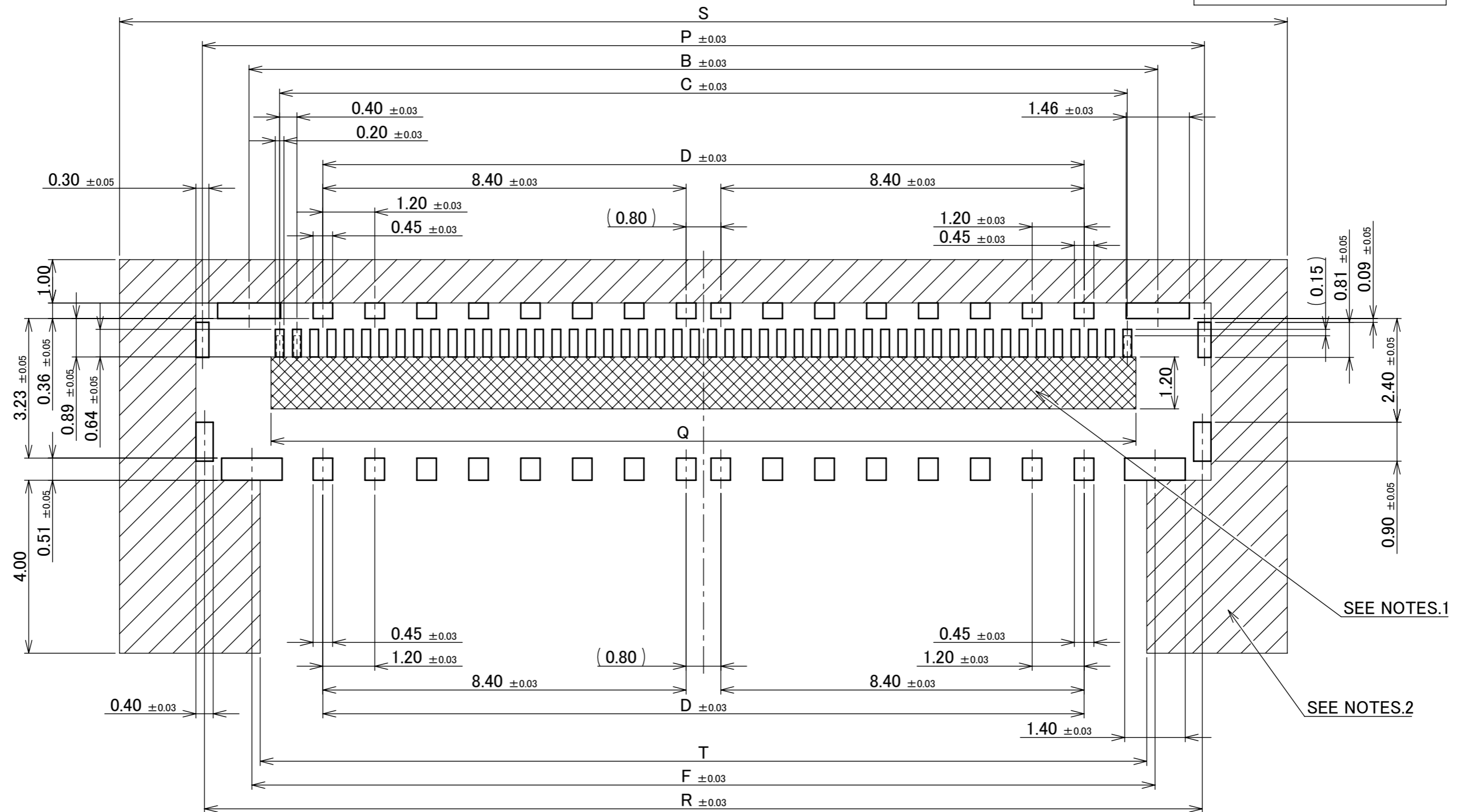

**#1 TYPE 50P RECOMMENDED PCB LAYOUT**  
(S=10/1)

- NOTES.**  
 1. SOLDER RESIST MUST BE APPLIED TO THIS AREA.  
 2. DO NOT MOUNT ANOTHER COMPONENT IN THIS AREA.

**PATENT PENDING**

ANGLE	±2°	6 OVER 30 MAX.	±0.3	PROJECTION ⊕	SERIES No. R5	CUSTOMER COPY		
6 MAX.	±0.2	30 OVER 120 MAX.	±0.5					
GENERAL TOLERANCE.				TITLE CABLIN <sup>®</sup> -UM RECEPTACLE ASSEMBLY	SCALE 10:1 UNIT mm	<b>I-PEX</b>		
DWG.	DATE							
CHK.								
APP.								
				DWG. No.	20879	SIZE A3	SHEET 7/17	REV. 14

PART No.	Pos.
20879-030E-#1	30
20879-040E-#1	40
20879-050E-#1	50
20879-060E-#1	60

# PATENT PENDING

#1 TYPE

With LOCK COVER

Without LOCK COVER & With PULL TAPE HOLDER

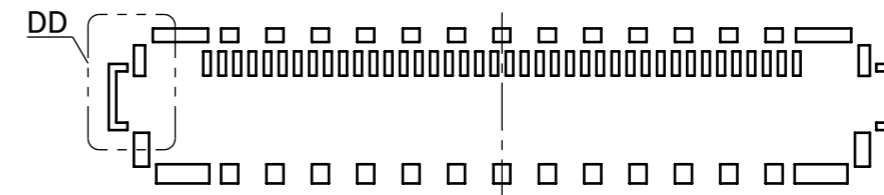
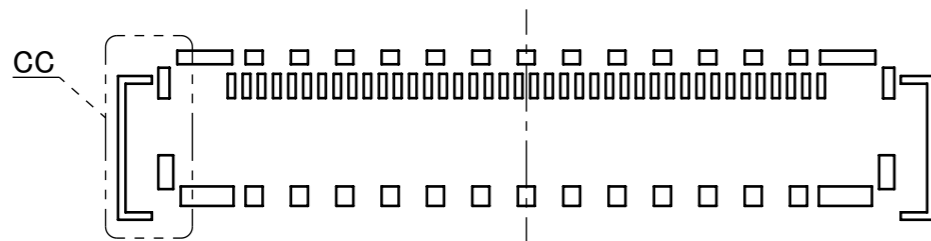

RECOMMENDED SILK PRINT For With LOCK COVER  
(S = 5 : 1)

RECOMMENDED SILK PRINT For Without LOCK COVER  
(S = 5 : 1)

SILK PRINT  
For PLUG INSERTION CHECK

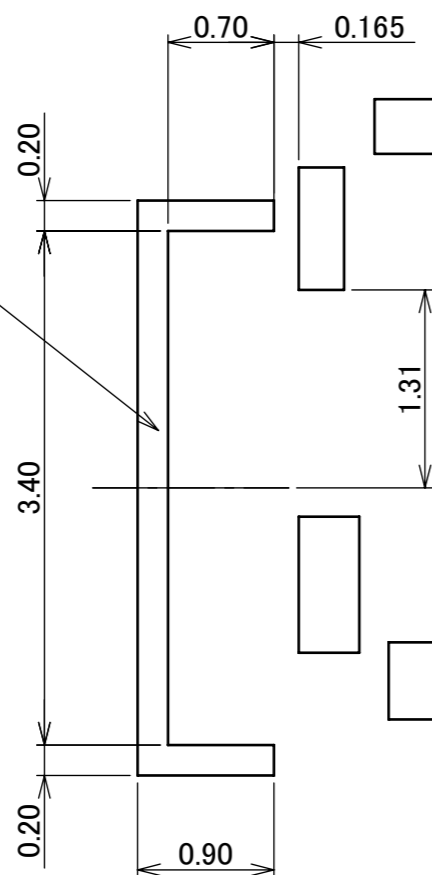

DETAIL CC  
(S = 20 : 1)

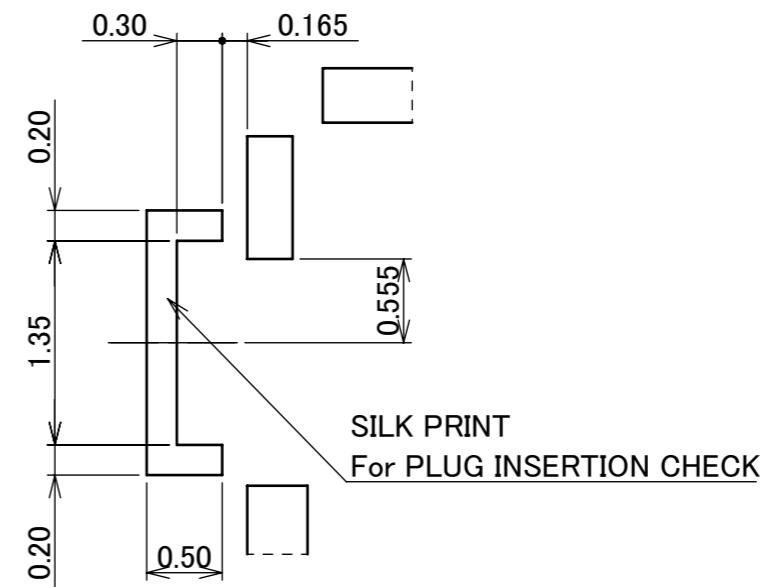

SILK PRINT  
For PLUG INSERTION CHECK

DETAIL DD  
(S = 20 : 1)

ANGLE	±2°	6 OVER 30 MAX.	±0.3	PROJECTION ⊕	SERIES No. R5	CUSTOMER COPY				
6 MAX.	±0.2	30 OVER 120 MAX.	±0.5							
GENERAL TOLERANCE.				TITLE CABLIN <sup>®</sup> -UM RECEPTACLE ASSEMBLY		SCALE	<b>I-PEX</b>			
DWG.	DATE					5:1				
CHK.						UNIT				mm
APP.						SIZE				SHEET
				DWG. No.	20879	A3	8/17	14		



PART No.	Pos.	C	K	L	Q	S	T	U	V	W	X
20879-030E-02	30	11.60	4.00	-	12.00	19.00	12.50	6.89	15.07	14.89	15.47
20879-040E-02	40	15.60	8.00	4.00	16.00	23.00	16.50	6.50	19.07	18.89	19.47
20879-060E-02	60	23.60	17.60	11.20	24.00	31.00	24.50	10.50	27.07	26.89	27.47

**PATENT PENDING**

**02 TYPE**

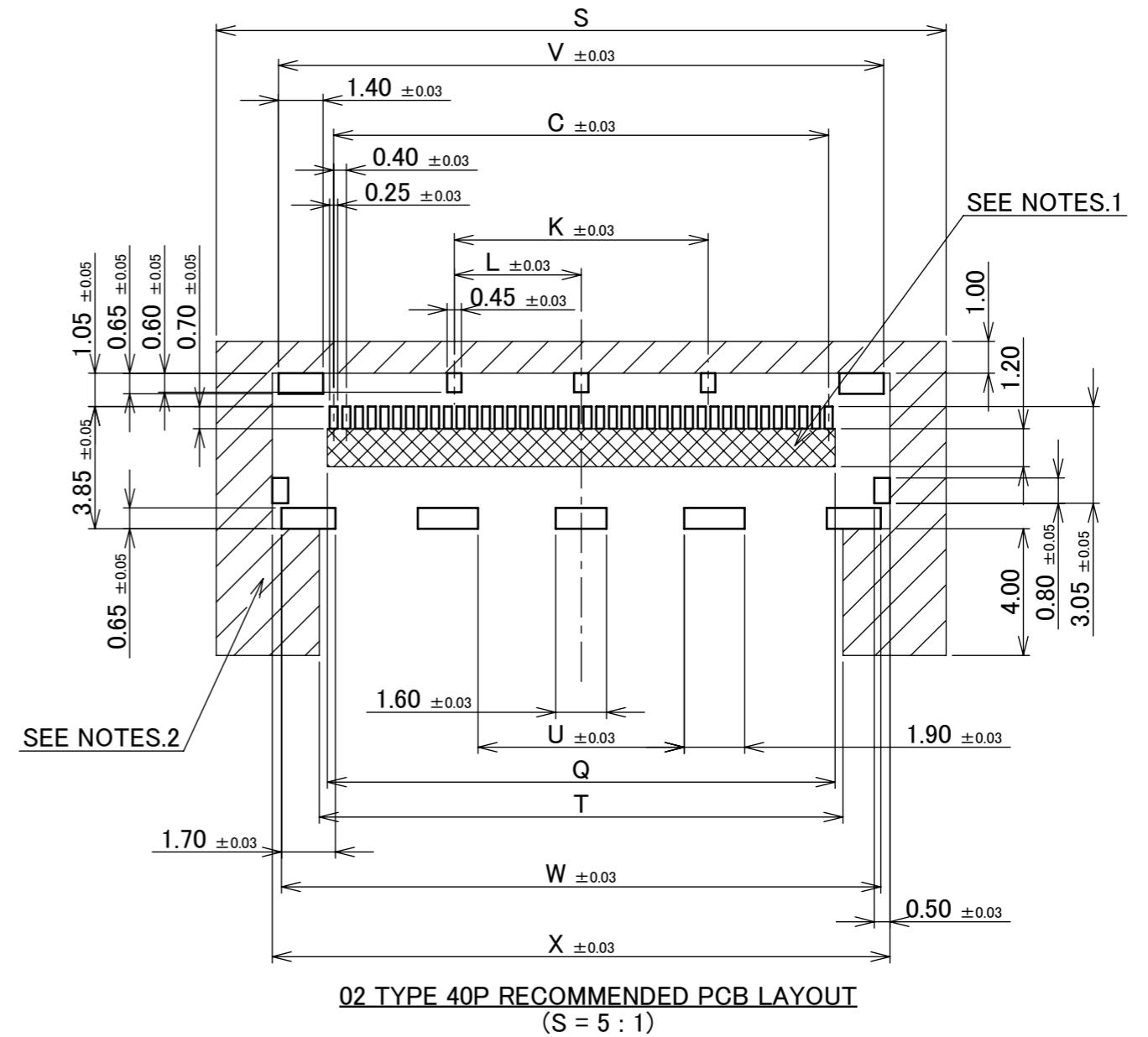
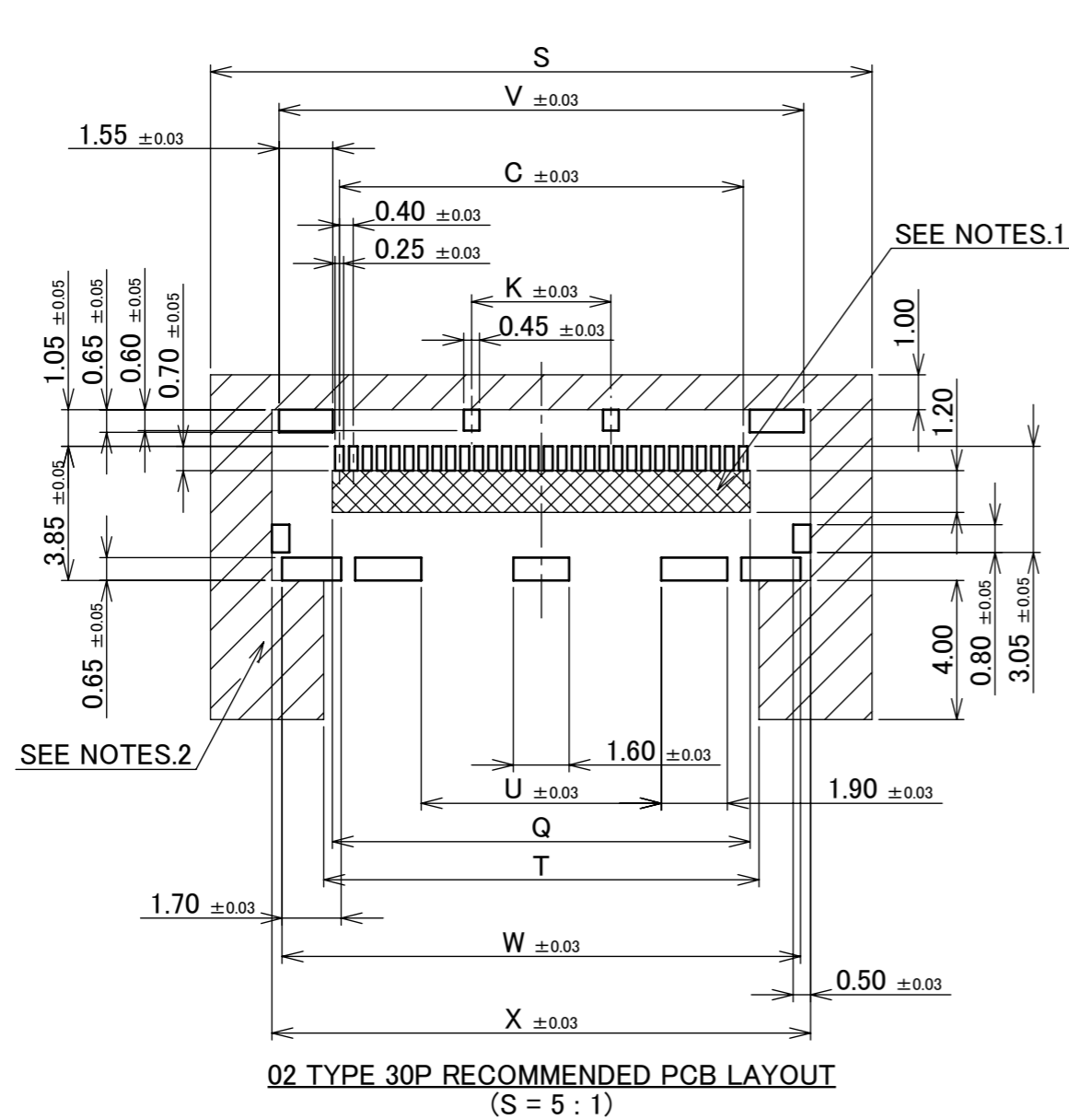

**NOTES.**

1. SOLDER RESIST MUST BE APPLIED TO THIS AREA.
2. DO NOT MOUNT ANOTHER COMPONENT IN THIS AREA.

ANGLE	±2°	6 OVER 30 MAX.	±0.3	PROJECTION ⊕	SERIES No. R5	CUSTOMER COPY			
	6 MAX.	±0.2	30 OVER 120 MAX.						±0.5
GENERAL TOLERANCE.				TITLE		SCALE	<b>I-PEX</b>		
DWG.	DATE			CABLINER <sup>®</sup> -UM RECEPTACLE ASSEMBLY		5:1			
CHK.						UNIT			
APP.						mm			
				DWG. No.	20879	SIZE	SHEET	REV.	
						A3	9/17	14	

PART No.	Pos.	C	K	L	Q	S	T	U	V	W	X	AD
20879-030E-02	30	11.60	4.00	-	12.00	19.00	12.50	6.89	15.07	14.89	15.47	-
20879-040E-02	40	15.60	8.00	4.00	16.00	23.00	16.50	6.50	19.07	18.89	19.47	-
20879-060E-02	60	23.60	17.60	11.20	24.00	31.00	24.50	10.50	27.07	26.89	27.47	3.20

**PATENT PENDING**

**02 TYPE**

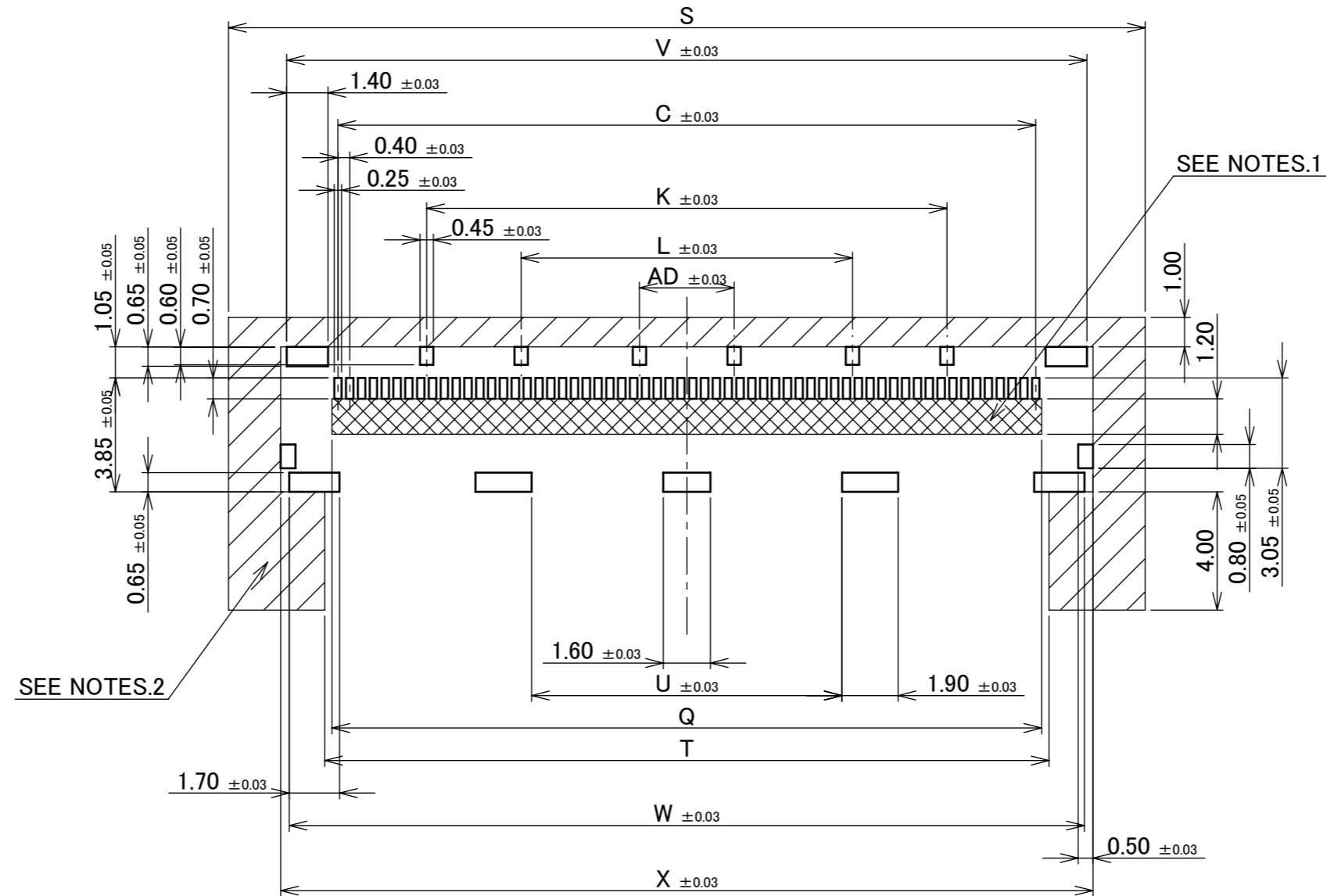

**02 TYPE 60P RECOMMENDED PCB LAYOUT**  
(S = 5 : 1)

**NOTES.**

1. SOLDER RESIST MUST BE APPLIED TO THIS AREA.
2. DO NOT MOUNT ANOTHER COMPONENT IN THIS AREA.

ANGLE	±2°	6 OVER 30 MAX.	±0.3	PROJECTION ⊕	SERIES No. R5	CUSTOMER COPY		
6 MAX.	±0.2	30 OVER 120 MAX.	±0.5					
GENERAL TOLERANCE.				TITLE CABLIN <sup>®</sup> -UM RECEPTACLE ASSEMBLY	SCALE 5:1 UNIT mm	<b>I-PEX</b>		
DWG.	DATE							
CHK.								
APP.								
				DWG. No.	20879	SIZE A3	SHEET 10/17	REV. 14

PART No.	Pos.	B	C	D	F	P	R
20879-030E-#1	30	13.01	11.60	9.60	12.88	15.17	15.07
20879-040E-#1	40	17.01	15.60	14.40	16.88	19.17	19.07
20879-060E-#1	60	25.01	23.60	21.60	24.88	27.17	27.07

**#1 TYPE**

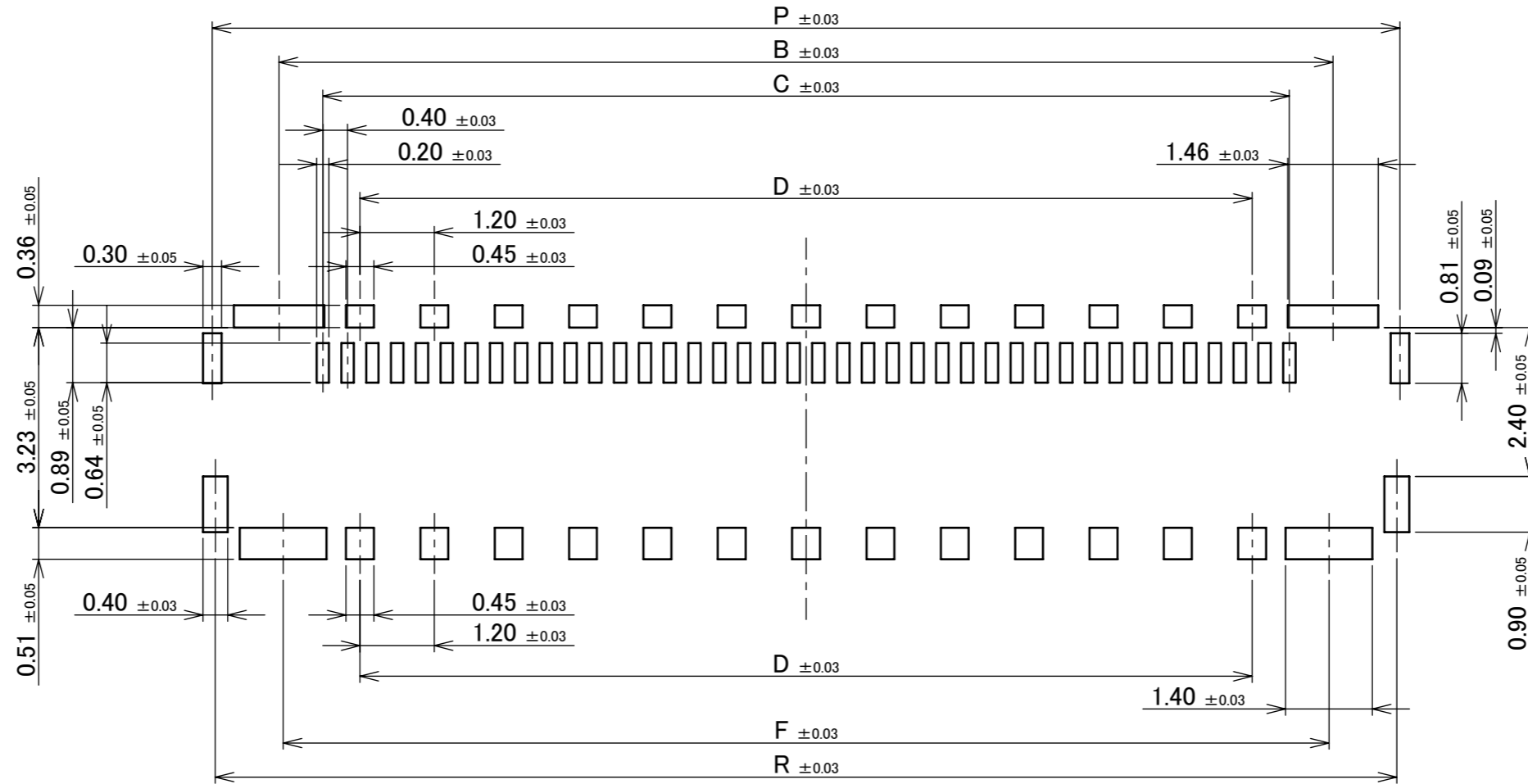

#1 TYPE 30P, 40P, 60P RECOMMENDED METAL MASK LAYOUT (S = 10 : 1)  
 ※ METAL MASK THICKNESS : t = 0.10

**PATENT PENDING**

ANGLE	±2°	6 OVER 30 MAX.	±0.3	PROJECTION 	SERIES No. R5	CUSTOMER COPY		
6 MAX.	±0.2	30 OVER 120 MAX.	±0.5					
GENERAL TOLERANCE.				TITLE CABLINÉ® -UM RECEPTACLE ASSEMBLY	SCALE 10:1 UNIT mm	<b>I-PEX</b>		
DWG.	DATE							
CHK.								
APP.								
				DWG. No.	20879	SIZE A3	SHEET 11/17	REV. 14

PART No.	Pos.	B	C	D	F	P	R
20879-050E-#1	50	21.01	19.60	17.60	20.88	23.17	23.07

#1 TYPE

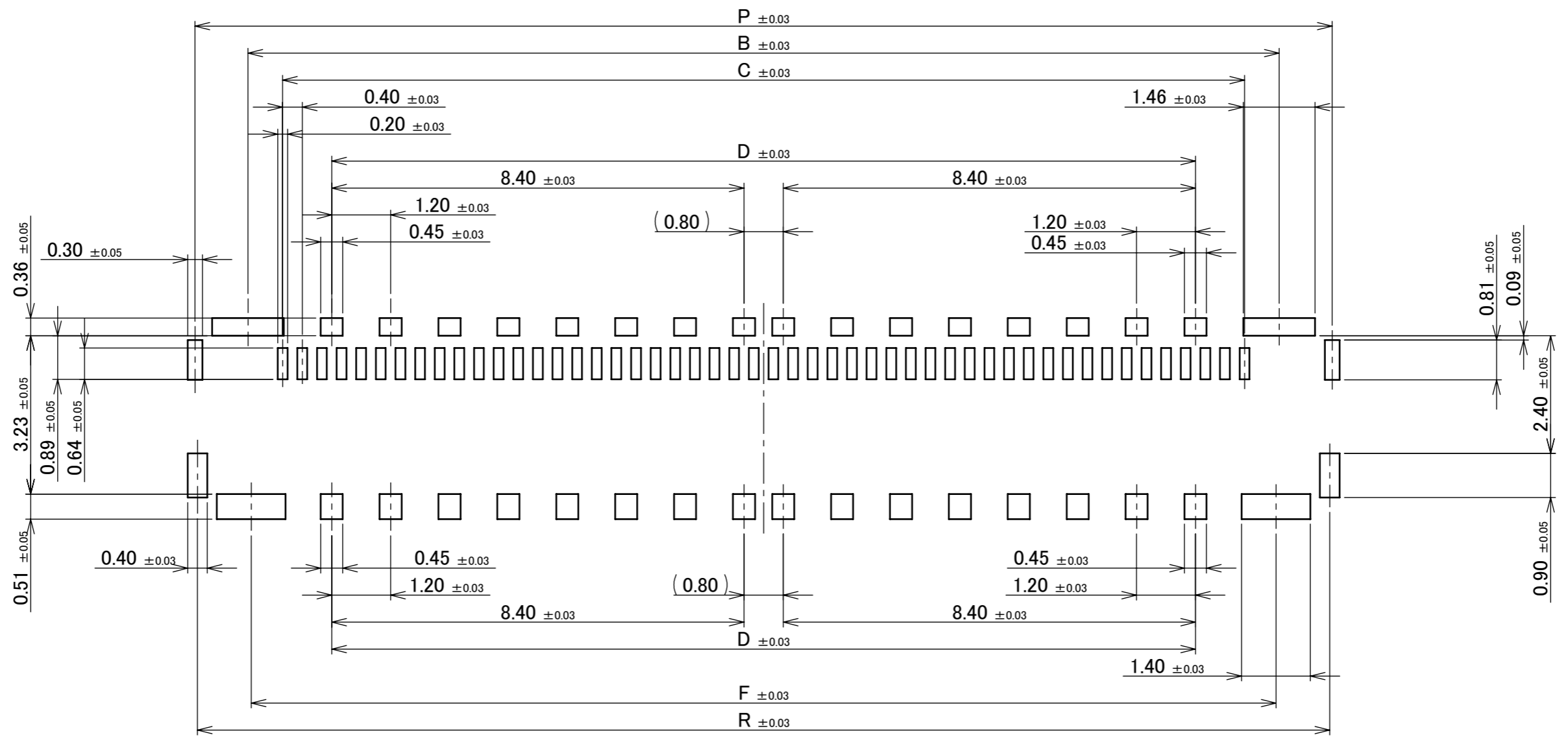

#1 TYPE 50P RECOMMENDED METAL MASK LAYOUT (S = 10 : 1)  
 ※ METAL MASK THICKNESS : t = 0.10

**PATENT PENDING**

ANGLE	±2°	6 OVER 30 MAX.	±0.3	PROJECTION ⊕	SERIES No. R5	CUSTOMER COPY			
	6 MAX.	±0.2	30 OVER 120 MAX.						±0.5
GENERAL TOLERANCE.				TITLE		SCALE	<b>I-PEX</b>		
DWG.	DATE			CABLIN <sup>®</sup> -UM RECEPTACLE ASSEMBLY		10:1			
CHK.						UNIT			
APP.				DWG. No. 20879		mm			
						SIZE	SHEET	REV.	
						A3	12/17	14	

PART No.	Pos.	C	K	L	U	V	W	X
20879-030E-02	30	11.60	4.00	-	6.89	15.07	14.89	15.47
20879-040E-02	40	15.60	8.00	4.00	6.50	19.07	18.89	19.47
20879-060E-02	60	23.60	17.60	11.20	10.50	27.07	26.89	27.47

# PATENT PENDING

# 02 TYPE

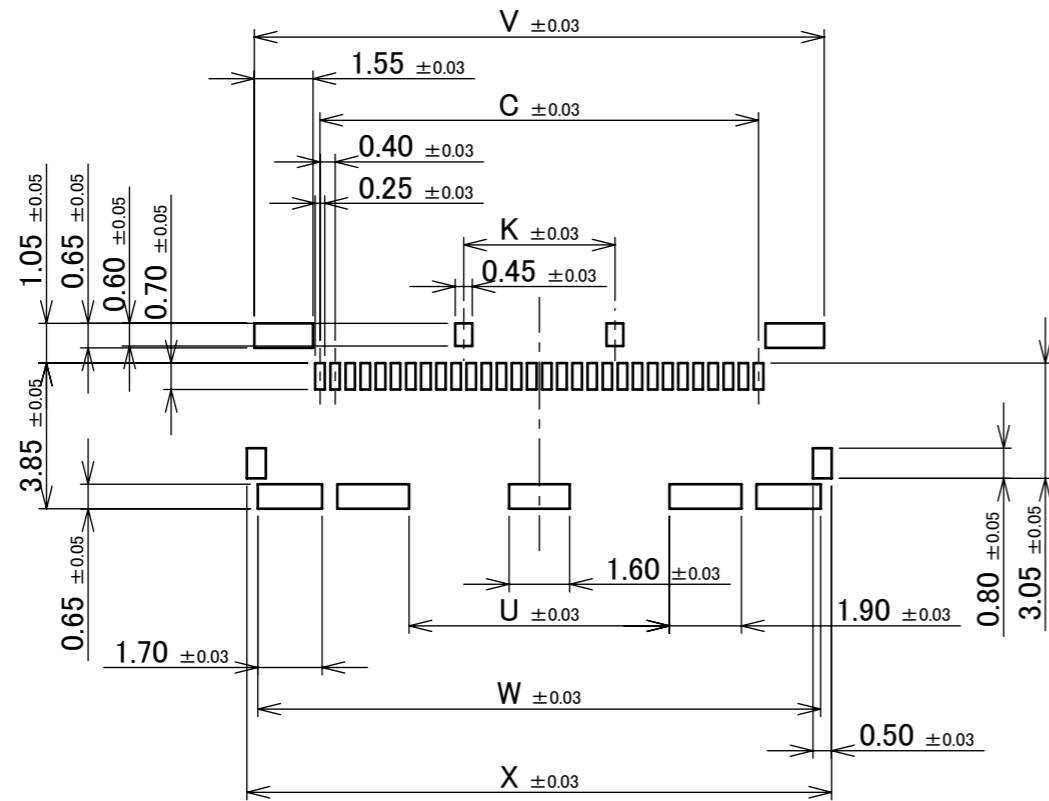

02 TYPE 30P RECOMMENDED METAL MASK LAYOUT (S = 5 : 1)  
 ※ METAL MASK THICKNESS : t = 0.12

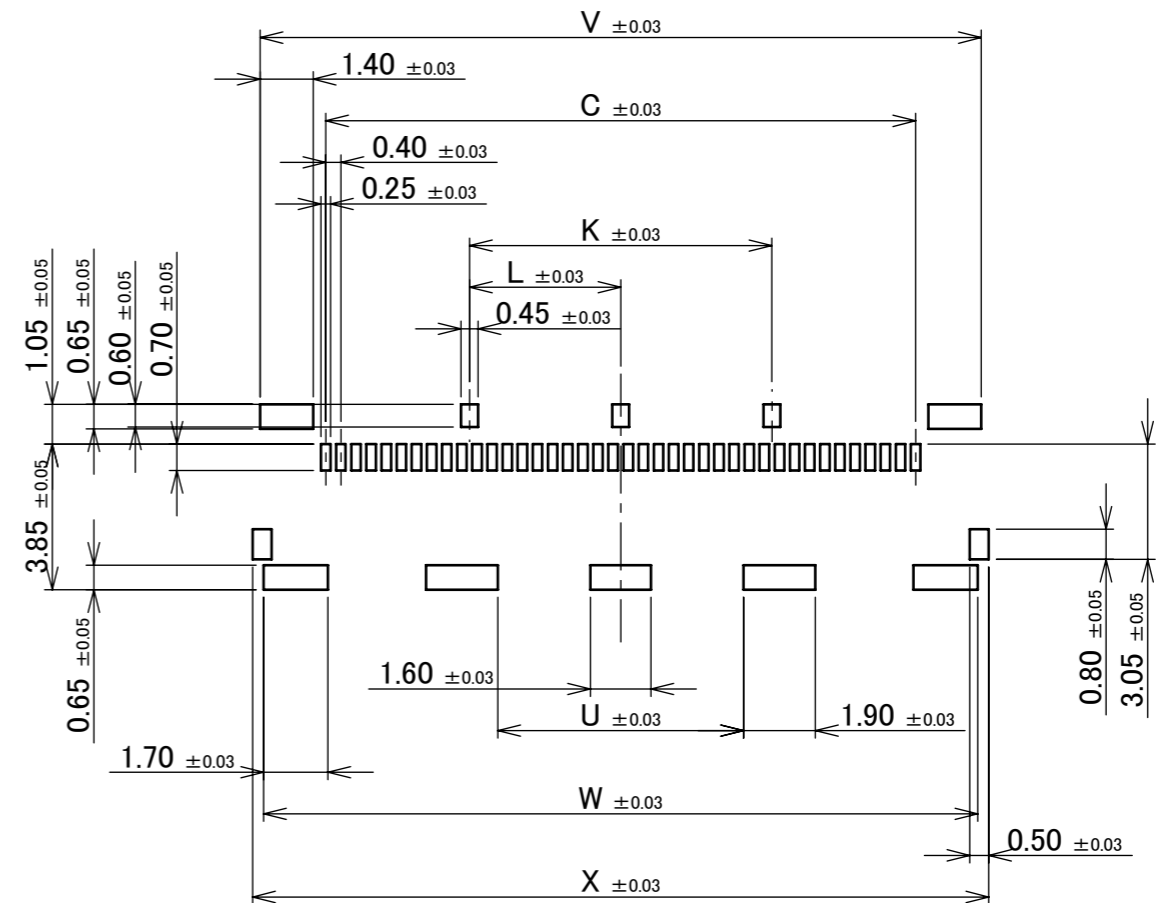

02 TYPE 40P RECOMMENDED METAL MASK LAYOUT (S = 5 : 1)  
 ※ METAL MASK THICKNESS : t = 0.12

ANGLE	±2°	6 OVER 30 MAX.	±0.3	PROJECTION 	SERIES No. R5	CUSTOMER COPY		
6 MAX.	±0.2	30 OVER 120 MAX.	±0.5			TITLE CABLIN <sup>®</sup> -UM RECEPTACLE ASSEMBLY	SCALE 5:1	<b>I-PEX</b>
GENERAL TOLERANCE.				DWG. No. 20879	UNIT mm	SIZE A3	SHEET 13/17	
DWG.	DATE							
CHK.								
APP.								

PART No.	Pos.	C	K	L	U	V	W	X	AD
20879-030E-02	30	11.60	4.00	-	6.89	15.07	14.89	15.47	-
20879-040E-02	40	15.60	8.00	4.00	6.50	19.07	18.89	19.47	-
20879-060E-02	60	23.60	17.60	11.20	10.50	27.07	26.89	27.47	3.20

# PATENT PENDING

# 02 TYPE

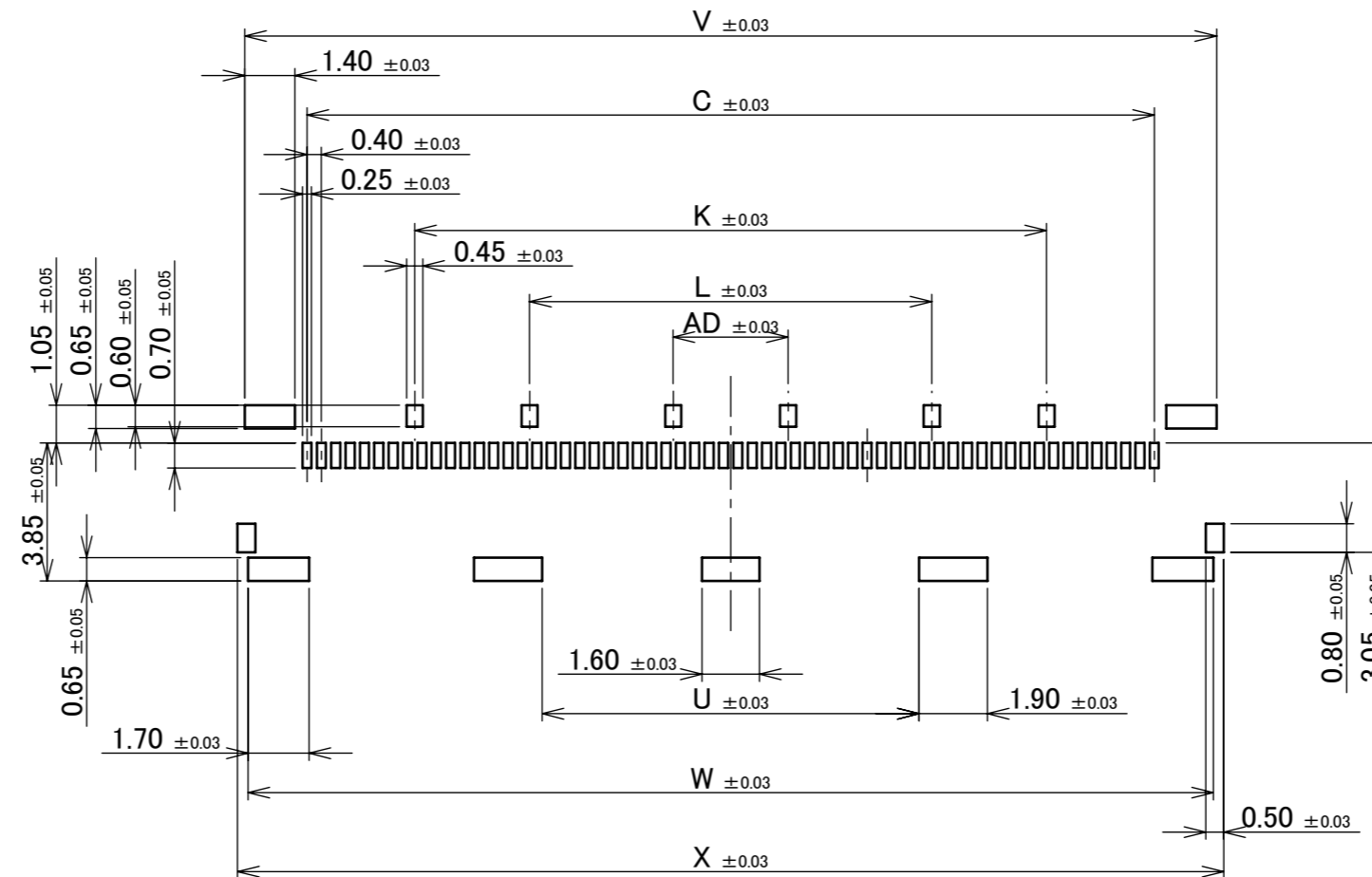

02 TYPE 60P RECOMMENDED METAL MASK LAYOUT (S = 5 : 1)  
 ※ METAL MASK THICKNESS : t = 0.12

ANGLE	±2°	6 OVER 30 MAX.	±0.3	PROJECTION 	SERIES No. R5	CUSTOMER COPY		
6 MAX.	±0.2	30 OVER 120 MAX.	±0.5					
GENERAL TOLERANCE.				TITLE CABLINÉ® -UM RECEPTACLE ASSEMBLY	SCALE 5:1 UNIT mm	I-PEX		
DWG.	DATE							
CHK.								
APP.								
				DWG. No.	20879	SIZE A3	SHEET 14/17	REV. 14

# PATENT PENDING

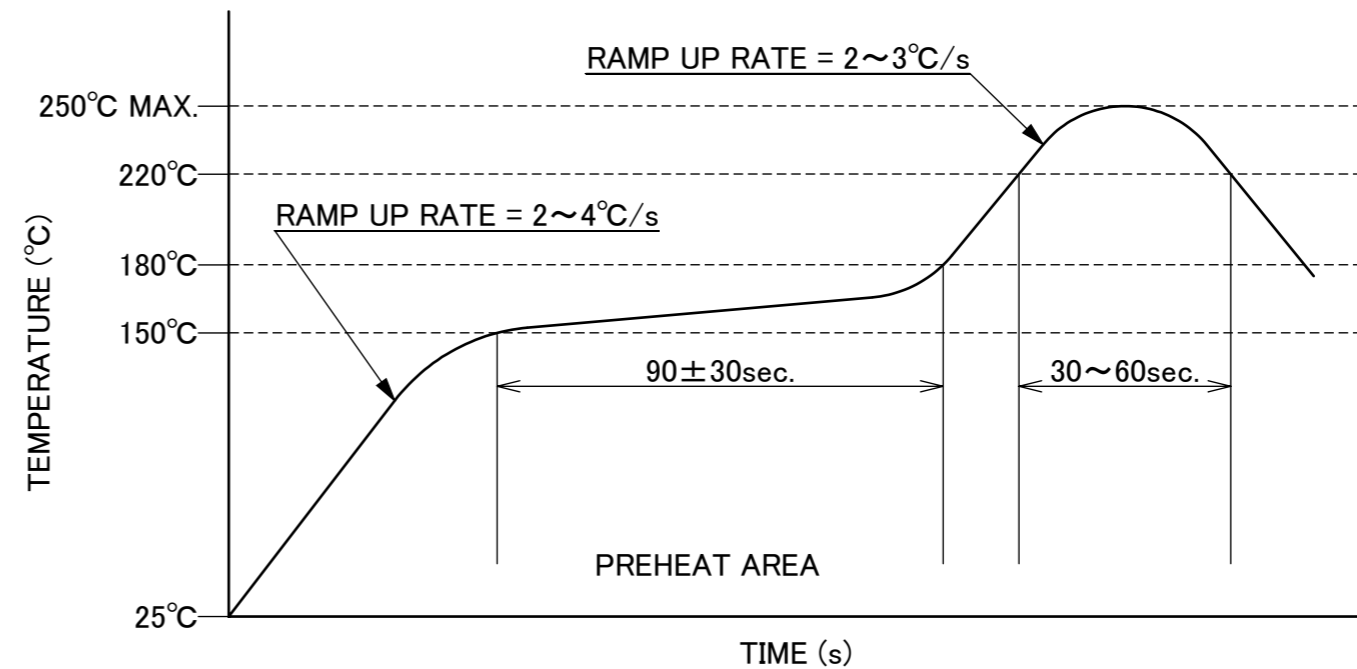
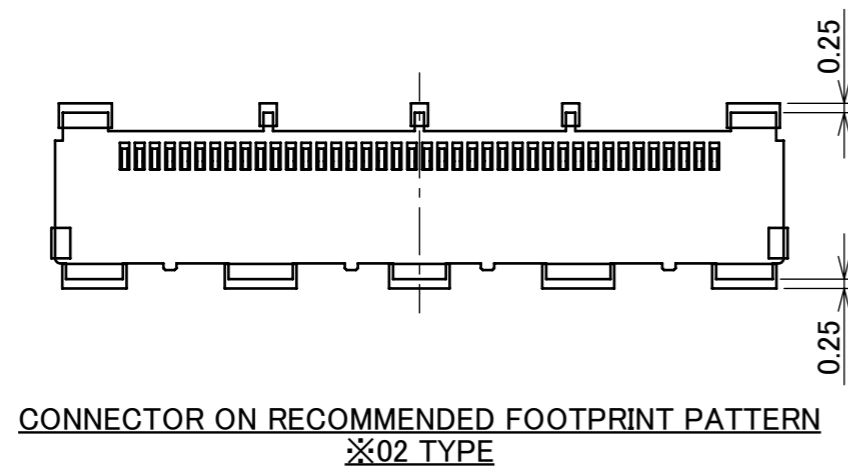
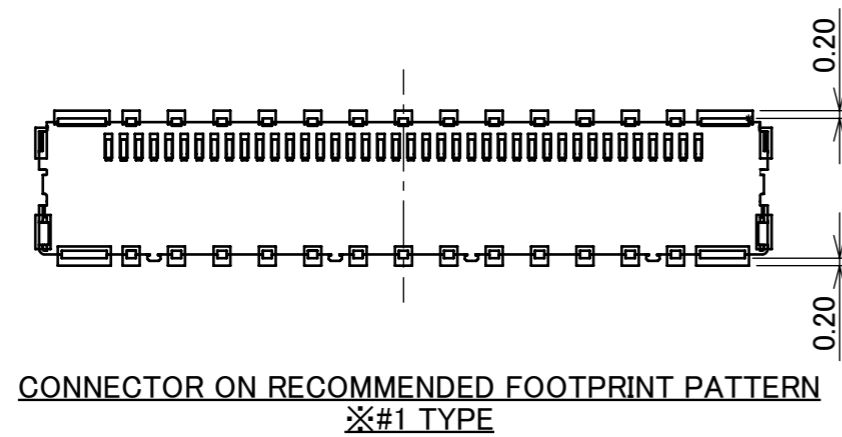

ANGLE	±2°	6 OVER 30 MAX.	±0.3	PROJECTION ⊕ ▽	SERIES No.	CUSTOMER COPY			
	6 MAX.	±0.2	30 OVER 120 MAX.		±0.5				R5
GENERAL TOLERANCE.				TITLE		SCALE	<b>I-PEX</b>		
DWG.	DATE			CABLIN <sup>®</sup> -UM RECEPTACLE ASSEMBLY		5:1			
CHK.						UNIT			
APP.				DWG. No.	20879	SIZE			
						A3	15/17	14	

PART NO.	Y	Z	AA	AB	AC	QTY. PER EMBOSS REEL (PIECES / REEL)	QTY. PER PACKING CARTON (REELS / CARTON)
20879-030E-#1	32.00	25.50	14.20	28.40	15.67	4500 / REEL	4 / CARTON = 18000
20879-040E-#1	32.00	25.50	14.20	28.40	19.67	4500 / REEL	4 / CARTON = 18000
20879-050E-#1	44.00	37.50	20.20	40.40	23.67	4500 / REEL	3 / CARTON = 13500
20879-060E-#1	44.00	37.50	20.20	40.40	27.67	4500 / REEL	3 / CARTON = 13500

**#1 TYPE**

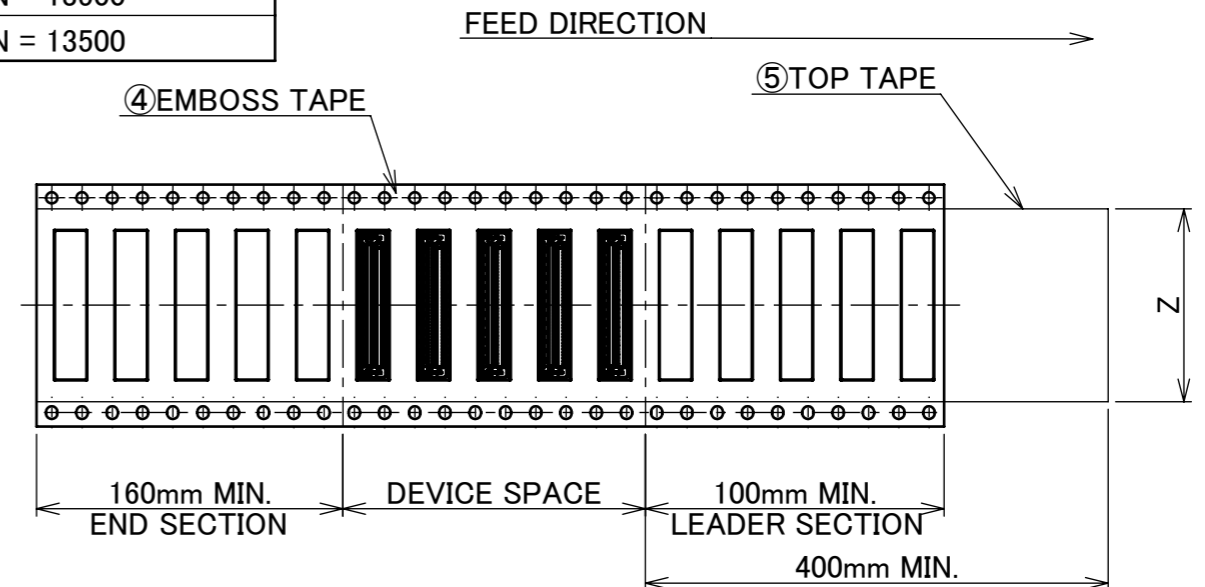
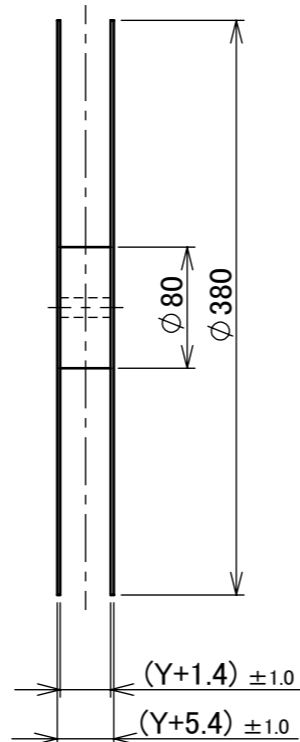
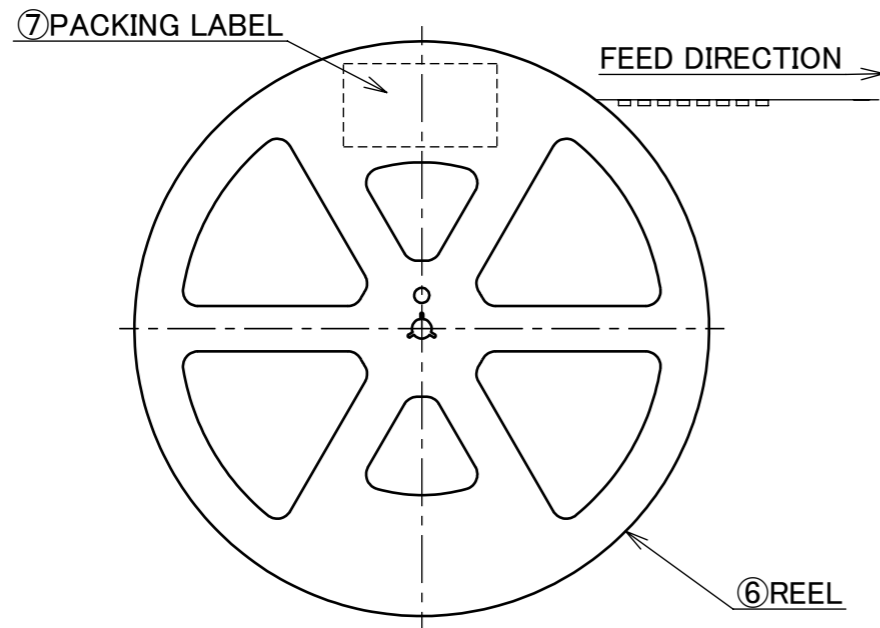

**PATENT PENDING**

NOTES.

- TAPING SPECIFICATION FOLLOWS JIS C 0806 (IEC 60286-3).
- MAKE EMPTY SECTION OF LEADER AND END ON EACH END OF THE TAPE.
- TOP TAPE SHALL NOT STICK OUT FROM EMBOSS TAPE.
- TOP TAPE SHALL NOT COVER FEED HOLE.

NO.	DISCRIPTION	MATERIAL	FINISH , REMARKS
7	PACKING LABEL	-	-
6	REEL	PS	ANTI-STATIC TYPE BLACK
5	TOP TAPE	PET t=0.062 TRANSPARENCY	ANTI-STATIC TYPE
4	EMBOSS TAPE	PS t=0.3 TRANSPARENCY	ANTI-STATIC TYPE

ANGLE	±2°	6 OVER 30 MAX.	±0.3	PROJECTION	SERIES No.	CUSTOMER COPY		
6 MAX.	±0.2	30 OVER 120 MAX.	±0.5		R5			
GENERAL TOLERANCE.				TITLE	SCALE		UNIT	
DWG.	DATE			CABLIN <sup>®</sup> -UM RECEPTACLE ASSEMBLY	1:X		I-PEX	
CHK.				DWG. No.	SIZE	SHEET	REV.	
APP.				20879	A3	16/17	14	

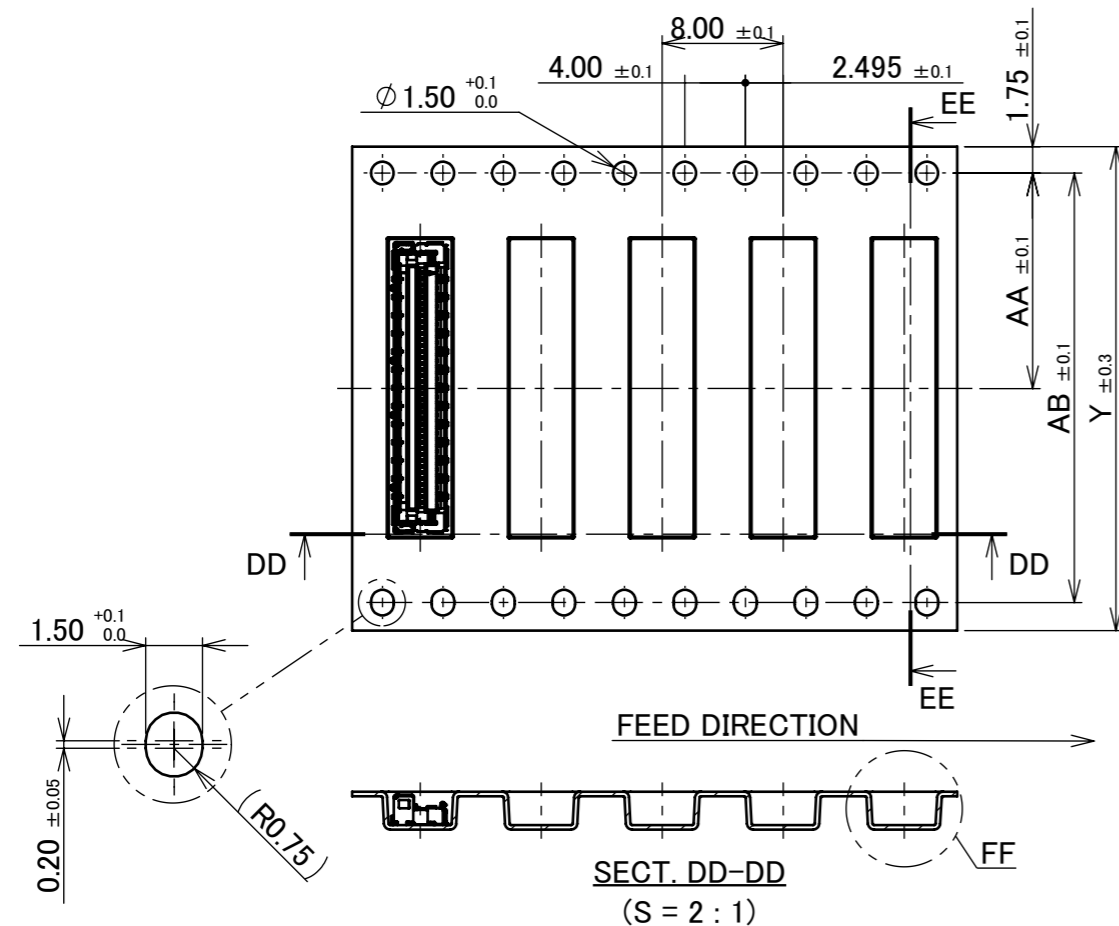



PART NO.	Y	Z	AA	AB	AC	QTY. PER EMBOSS REEL (PIECES / REEL)	QTY. PER PACKING CARTON (REELS / CARTON)
20879-030E-02	32.00	25.50	14.20	28.40	15.67	4500 / REEL	4 / CARTON = 18000
20879-040E-02	32.00	25.50	14.20	28.40	19.67	4500 / REEL	4 / CARTON = 18000
20879-060E-02	44.00	37.50	20.20	40.40	27.67	4500 / REEL	3 / CARTON = 13500

**02 TYPE**

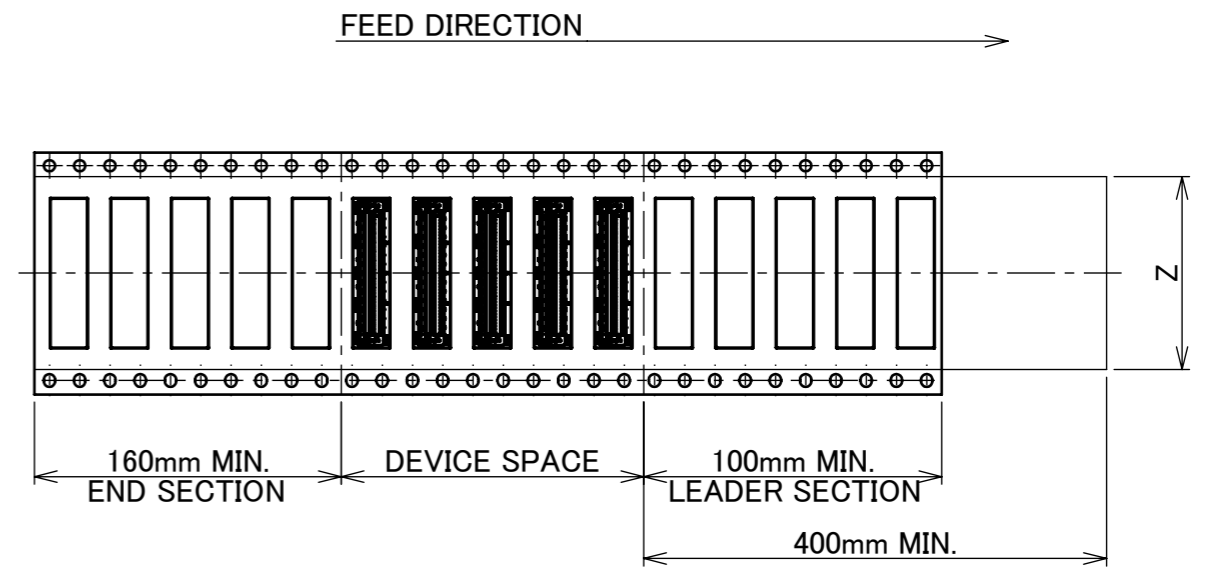
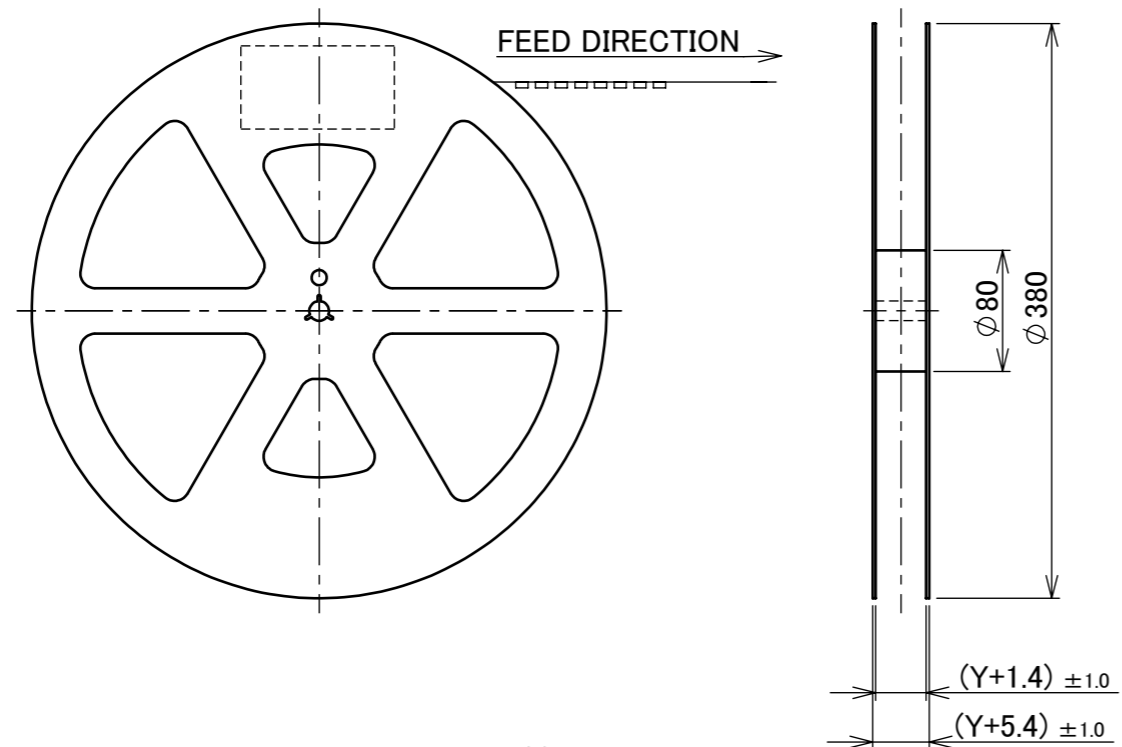

**PATENT PENDING**

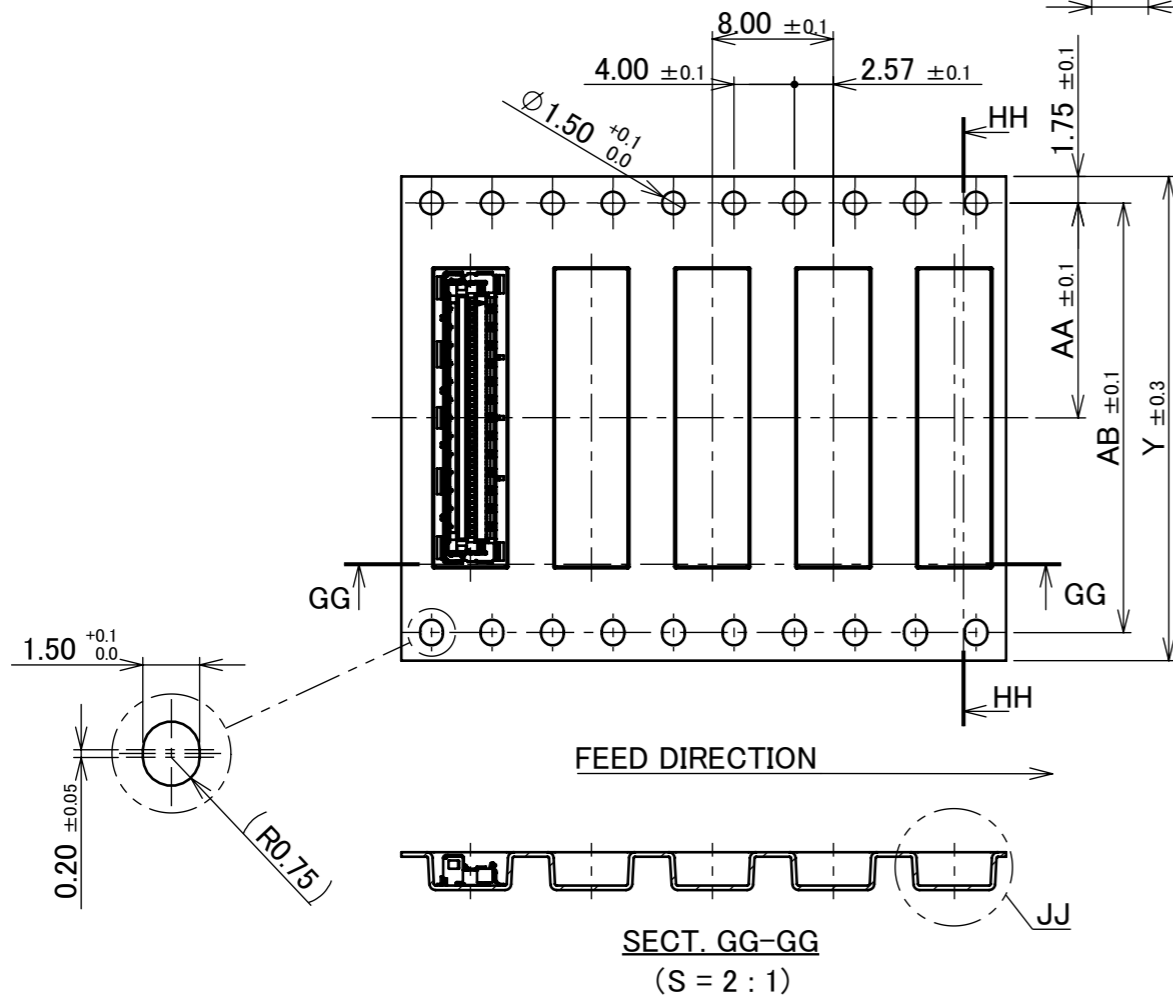

- NOTES.
3. TAPING SPECIFICATION FOLLOWS JIS C 0806 (IEC 60286-3).
  4. MAKE EMPTY SECTION OF LEADER AND END ON EACH END OF THE TAPE.
  5. TOP TAPE SHALL NOT STICK OUT FROM EMBOSS TAPE.
  6. TOP TAPE SHALL NOT COVER FEED HOLE.

ANGLE	±2°	6 OVER 30 MAX.	±0.3	PROJECTION ⊕	SERIES No. R5	CUSTOMER COPY		
	6 MAX.	±0.2	30 OVER 120 MAX.			±0.5	SCALE 1:X	<b>I-PEX</b>
GENERAL TOLERANCE.				TITLE CABLIN <sup>®</sup> -UM RECEPTACLE ASSEMBLY		UNIT mm		
DWG.	DATE			DWG. No. 20879		SIZE A3	SHEET 17/17	REV. 14
CHK.								
APP.								