

Recommended P/N 20472-0**T-10

PART NO.	POS.	A	B	C	D
20472-030T-10	30	11.60	12.40	18.44	13.00
20472-040T-10	40	15.60	16.40	22.44	17.00

P/N : 20472-#**T-10

POS.
0: WITH LATCH BAR
1: WITHOUT LATCH BAR

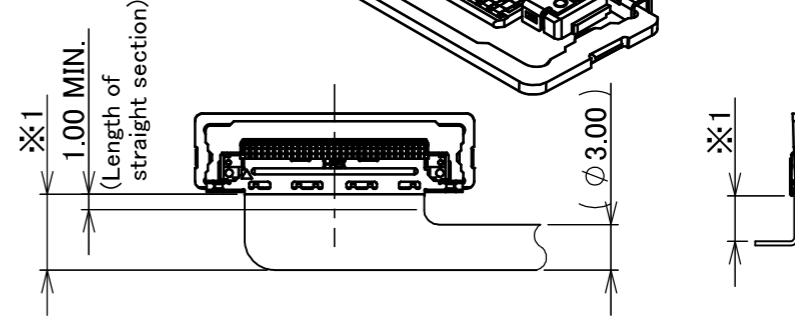
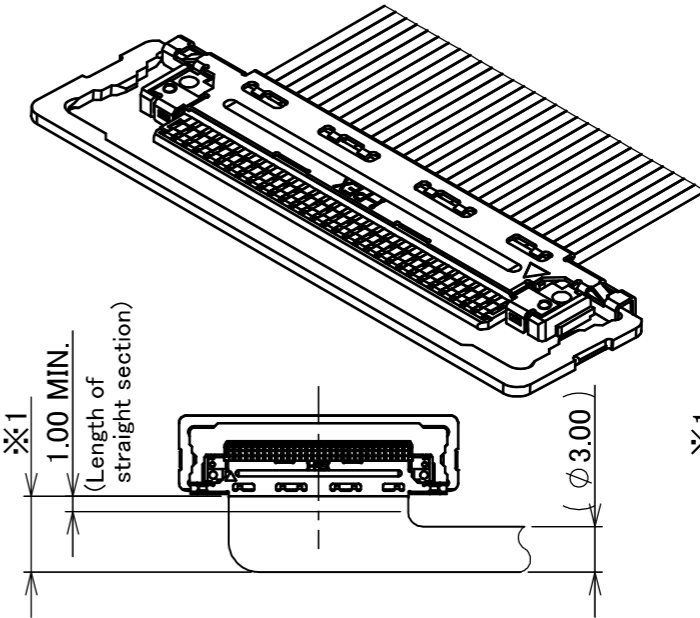
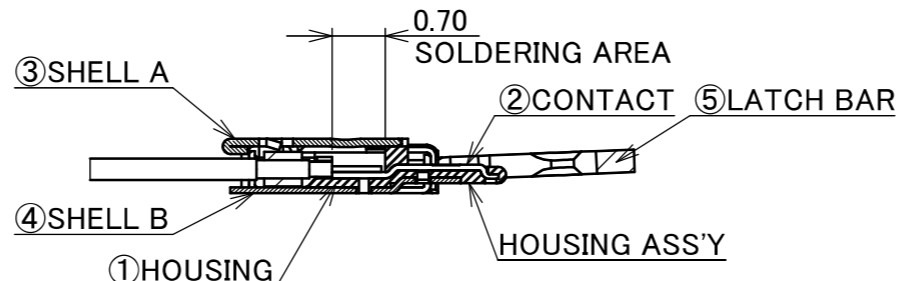
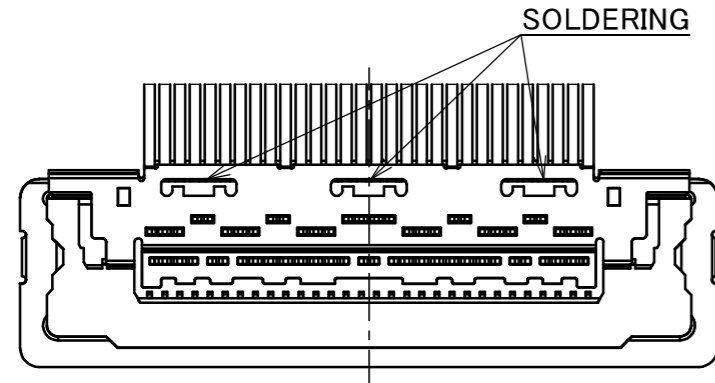

REFERENCE CABLE BENDING DIMENSIONS
 ※1: THE BEND DIMENSIONS MAY VARY BASED ON THE SIZE AND QUANTITY OF CABLES. PLEASE CONFIRM THE MINIMUM BENDING RADIUS WITH I-PEX OR THE HARNESS MANUFACTURER.

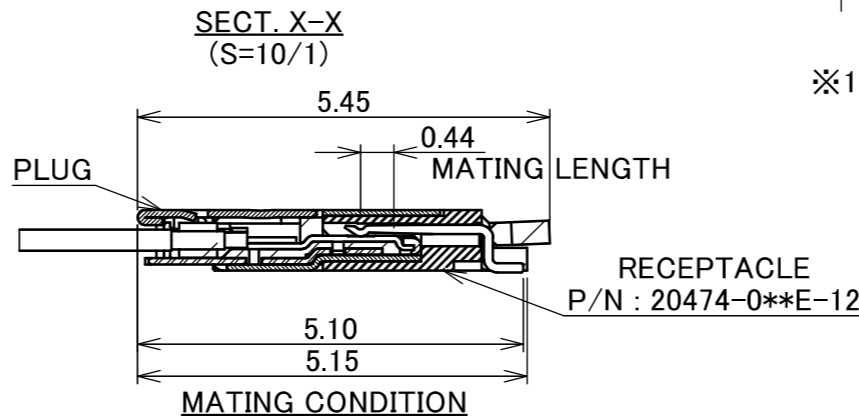

MATING CONDITION

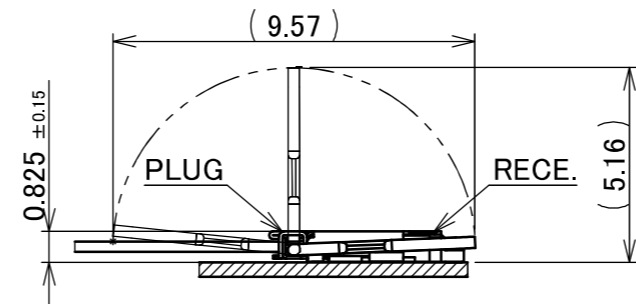

LATCH MOVEMENTS

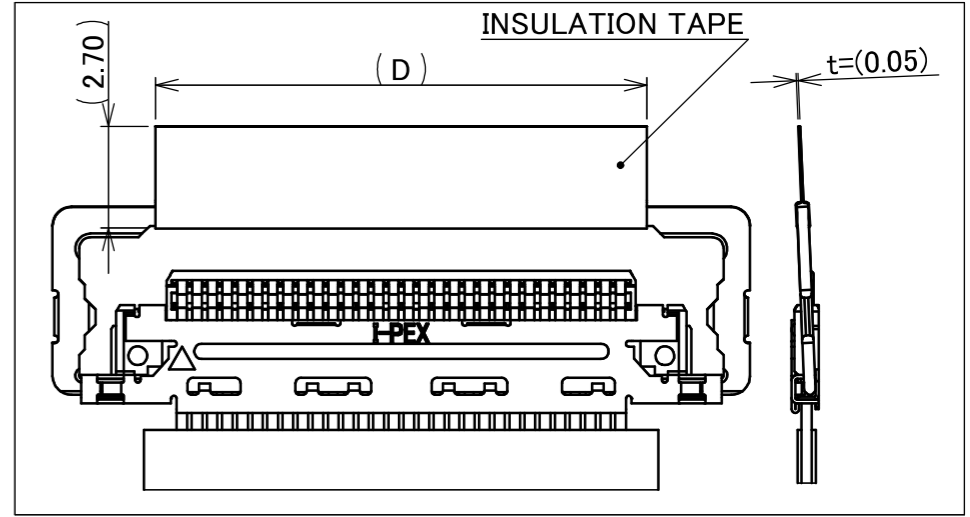

INSULATION TAPE RECOMMENDED DIMENSIONS

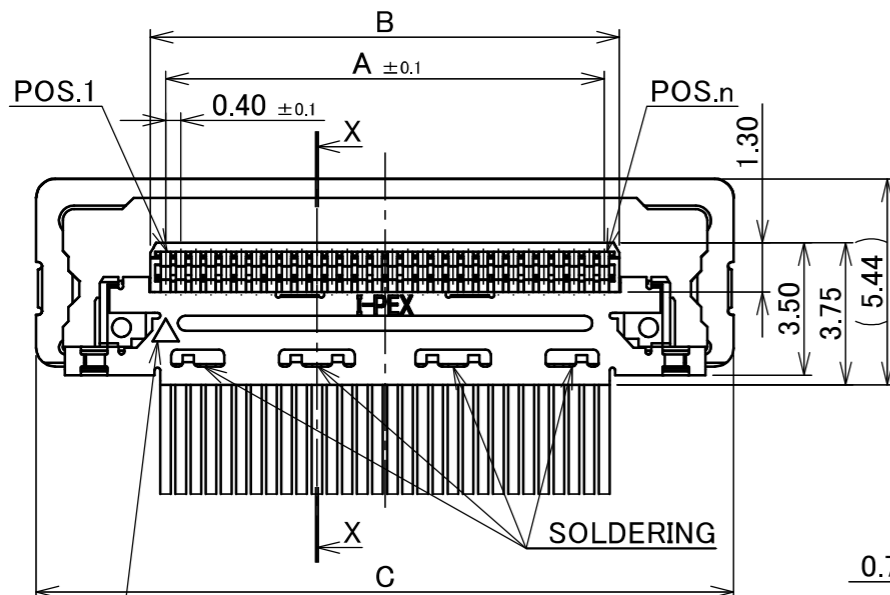

DATUM MARK

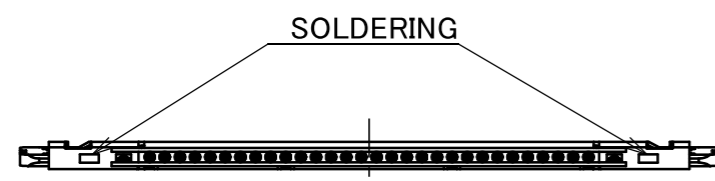

WITH LATCH BAR

NO.	DISCRIPTION	MATERIAL	FINISH , REMARKS
5	LATCH BAR	SUS	
4	SHELL B	PHOSPHOR BRONZE	Au 0.05 μ m MIN. OVER Ni 1.00 μ m MIN.
3	SHELL A	PHOSPHOR BRONZE	Au 0.05 μ m MIN. OVER Ni 1.00 μ m MIN.
2	CONTACT	PHOSPHOR BRONZE	Au 0.1 μ m MIN. OVER Ni 1.00 μ m MIN.
1	HOUSING	LCP	UL94V-0, BLACK

REV.	ECN	BY	DATE	APP.	APP.	CHK.	DATE	PROJECTION	SERIES No.	TITLE	SCALE	SHEET	REV.
15	Z250302	S.K	Mar./03/'25	T.M	ANGLE	±2°	6 OVER 30 MAX.	±0.3	R3R0R1	CABLINER [®] -CBL PLUG CABLE ASSEMBLY	5:1	A3	15
14	Z241417	K.Ta	Oct./11/'24	T.M	6 MAX.	±0.2	30 OVER 120 MAX.	±0.5					
13	Z231029	H.U	Sept./26/'23	T.M	GENERAL TOLERANCE.								
12	Z220246	TSU	Mar./08/'22	H.I	DWG.	T.Shiiya	DATE	2009/01/13					
11	Z211210	R.M	Oct./04/'21	H.I	CHK.	-							
10	Z180949	M.N	July/20/'18	Y.S	APP.	E.Kawabe			20472		1/4		

I-PEX Inc.

Confidential C

QKE-DFE06-02 REV.12

Recommended P/N 20472-0**T-10

PART NO.	POS.	A	B	E
20472-130T-10	30	11.60	12.40	16.94
20472-140T-10	40	15.60	16.40	20.94

P/N : 20472-***T-10

POS.

0: WITH LATCH BAR
1: WITHOUT LATCH BAR



Halogen Free



RoHS Compliant

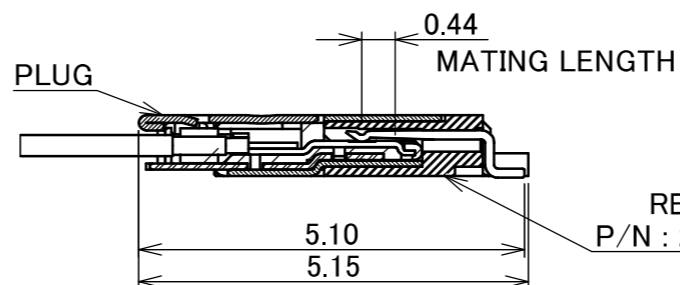
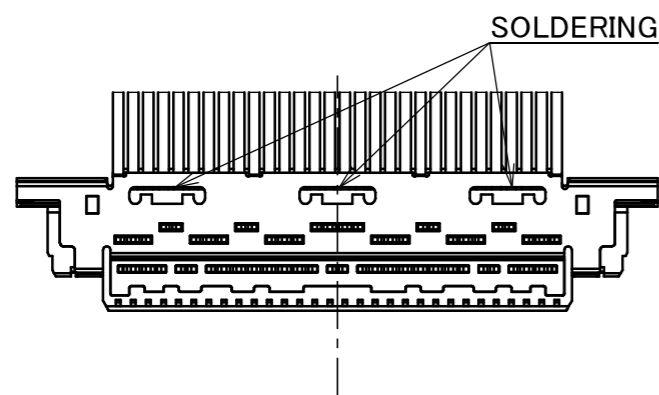

MATING CONDITION

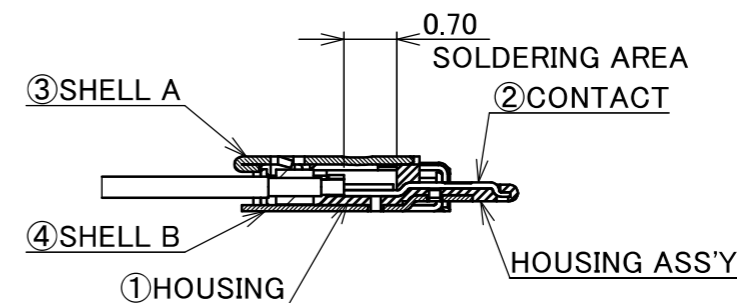
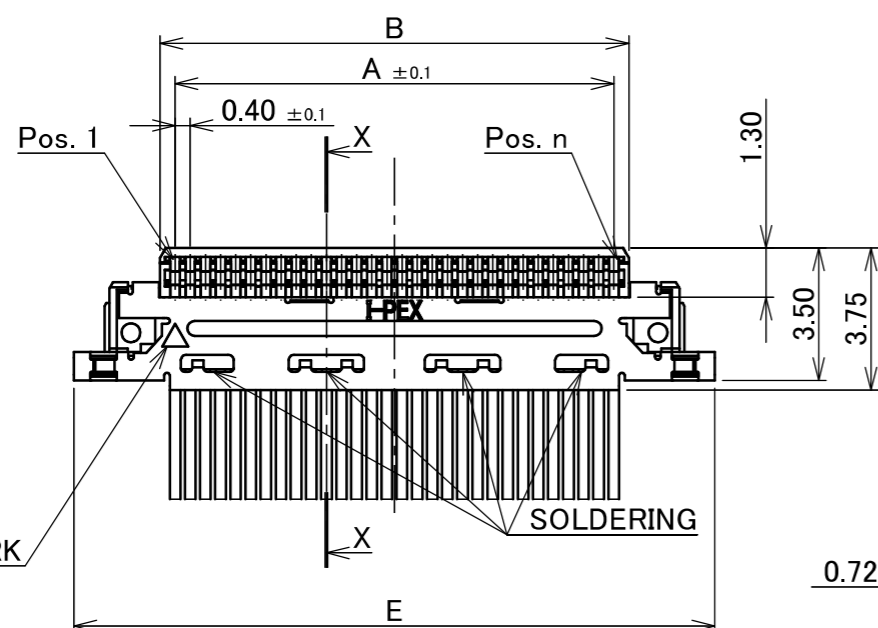
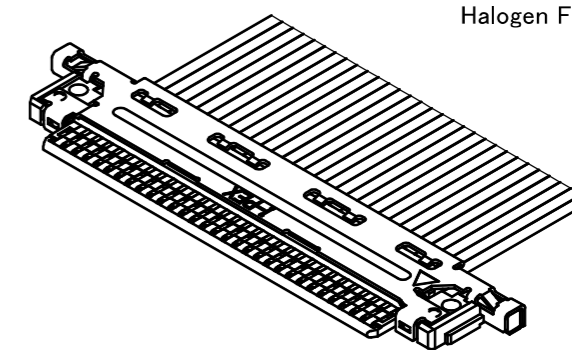

SECT. X-X
(S=10/1)

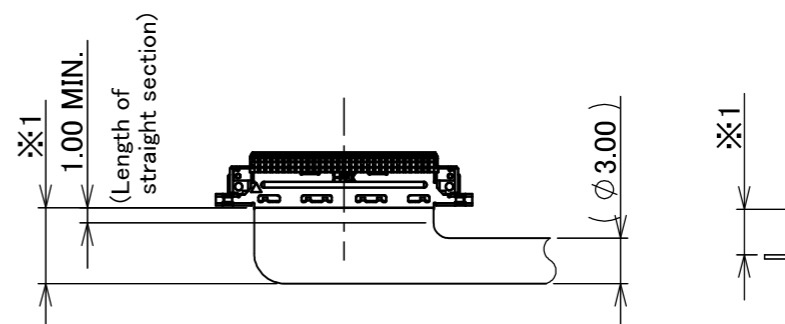

REFERENCE CABLE BENDING DIMENSIONS

※1: THE BEND DIMENSIONS MAY VARY BASED ON THE SIZE AND QUANTITY OF CABLES.
PLEASE CONFIRM THE MINIMUM BENDING RADIUS WITH I-PEX OR THE HARNESS MANUFACTURER.

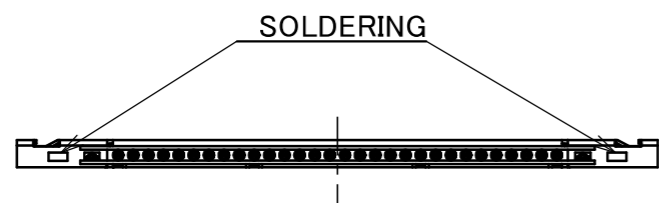

WITHOUT LATCH BAR

ANGLE	±2°	6 OVER 30 MAX.	±0.3	PROJECTION ⊕	SERIES No. R3R0R1	CUSTOMER COPY		
6 MAX.	±0.2	30 OVER 120 MAX.	±0.5			SCALE 5:1 UNIT mm	I-PEX	
GENERAL TOLERANCE.				TITLE CABLINER [®] -CBL PLUG CABLE ASSEMBLY		SIZE A3		
DWG.	DATE			DWG. No. 20472				
CHK.								
APP.								

ITEMS	SPECIFICATION
APPLICABLE CABLE	MICRO-COAXIAL CABLE : AWG# 40, 42, 44 DISCRETE WIRE : AWG# 36
RATING VOLTAGE	100V AC (PER CONTACT PIN) ※THIS IS THE RATED VOLTAGE OF THE CONNECTOR. PLEASE NOTE THAT THE RATED VOLTAGE MAY VARY IN THE HARNESS DEPENDING ON THE CABLES USED.
RATING AMPERAGE (FOR CONTACT)	0.1A AC/DC [AWG#44] PER CONTACT PIN 0.24A AC/DC [AWG#42] PER CONTACT PIN 0.3A AC/DC [AWG#40] PER CONTACT PIN 0.8A AC/DC [AWG#36] PER CONTACT PIN ※TESTING BY A REAL MACHINE IS RECOMMENDED BECAUSE TEMPERATURE RISE MAY AFFECTED BY ACTUAL SITUATION.
OPERATING TEMPERATURE	233~358K(-40°C~+85°C)
OPERATING HUMIDITY	85% MAX.
CONTACT RESISTANCE	INITIAL : 275mohm MAX. (AWG#36)/ AFTER TEST : \triangleleft 40mohm MAX. 600mohm MAX. (AWG#40) 700mohm MAX. (AWG#42) 1080mohm MAX. (AWG#44)
GROUND SHELL RESISTANCE	INITIAL : 50mohm MAX. / AFTER TEST : \triangleleft 40mohm MAX.
INSULATION RESISTANCE	INITIAL : 1000Mohm MIN. / AFTER TEST : 500Mohm MIN.
DIELECTRIC WITHSTANDING VOLTAGE	AC250V 1min
DURABILITY	30 CYCLES
MATING FORCE (INITIAL / AFTER TEST)	30P : 10N MAX. 40P : 12N MAX.
UNMATING FORCE (INITIAL / AFTER TEST)	30P : 3.0N MIN. 40P : 4.0N MIN.
CABLE RETENTION FORCE	30P : 14.70N MIN. 40P : 19.60N MIN.
PRODUCT SPECIFICATION	PRS-1421
TEST REPORT	TR-08030
INSTRUCTION MANUAL	HIM-09002
ASSEMBLY MANUAL	ASM-09002
APPEARANCE CRITERIA No.	QLS-A***

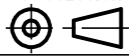
ANGLE	$\pm 2^\circ$	6 OVER 30 MAX.	± 0.3	PROJECTION 	SERIES No. R3R0R1	CUSTOMER COPY		
6 MAX.	± 0.2	30 OVER 120 MAX.	± 0.5					
GENERAL TOLERANCE.				TITLE CABLIN [®] -CBL PLUG CABLE ASSEMBLY	SCALE	I-PEX		
DWG.	DATE							
CHK.								
APP.								
DWG. No.	20472			SIZE	SHEET	REV.		
				A3	3/4	15		

PART NO.	POS.	A
20472-#30T-10	30	11.60
20472-#40T-10	40	15.60

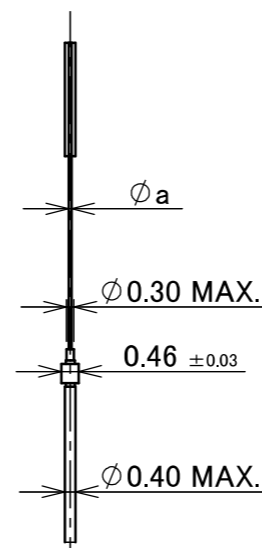
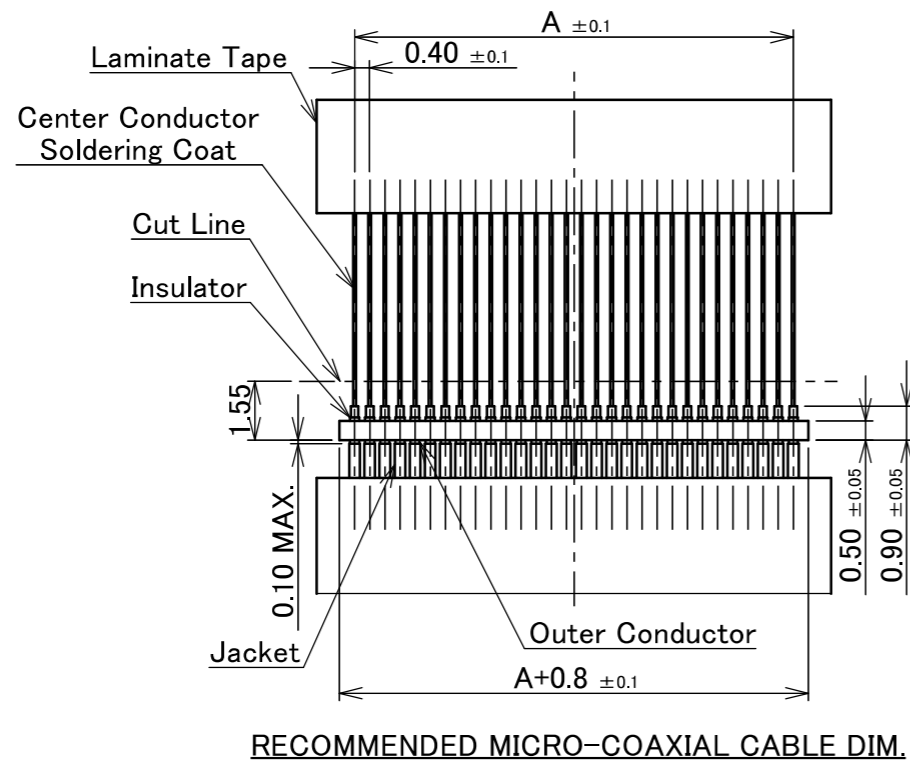

MICRO-COAXIAL CABLE DIM.

	a
#40	0.09
#42	0.075
#44	0.063

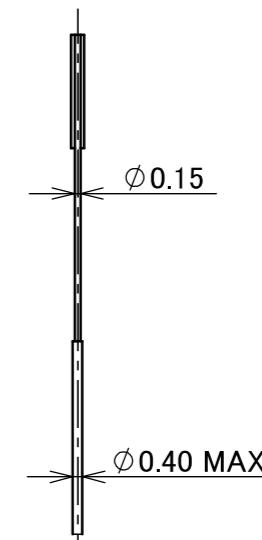

ANGLE	$\pm 2^\circ$	6 OVER 30 MAX.	± 0.3	PROJECTION	SERIES No.	CUSTOMER COPY			
	6 MAX.	± 0.2	30 OVER 120 MAX.	± 0.5		R3R0R1			
GENERAL TOLERANCE.				TITLE		SCALE	I-PEX		
DWG.	DATE			CABLIN [®] -CBL PLUG CABLE ASSEMBLY		5:1			
CHK.						UNIT			
APP.				DWG. No.		mm			
				20472		SIZE	SHEET	REV.	
						A3	4/4	15	