

Recommended P/N 20525-0**E-02(12~60P) 20525-210E-02(10P)

PART NO.	POS.	A	B	C	D	F
20525-#10E-02	10	5.40	3.60	8.43	9.20	4.30
20525-#12E-02	12	6.20	4.40	9.23	10.00	5.10
20525-#20E-02	20	9.40	7.60	12.43	13.20	8.30
20525-#30E-02	30	13.40	11.60	16.43	17.20	12.30
20525-#40E-02	40	17.40	15.60	20.43	21.20	16.30
20525-#50E-02	50	21.40	19.60	24.43	25.20	20.30
20525-#60E-02	60	25.40	23.60	28.43	29.20	24.30

PATENT REGISTERED



Halogen Free



RoHS Compliant

P/N : 20525-#**E-02

POS.
SEE TABLE 1

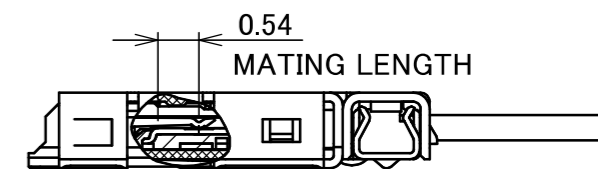

MATING CONDITION

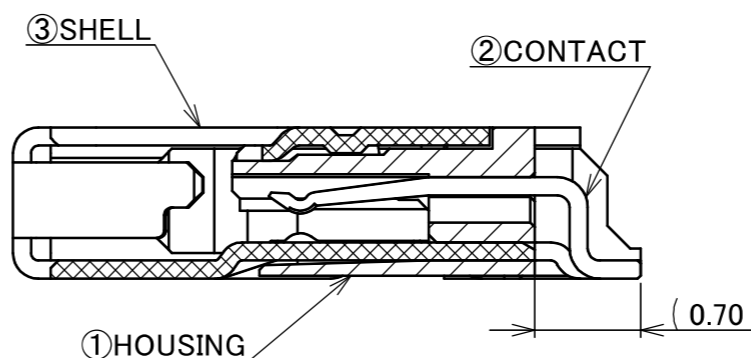
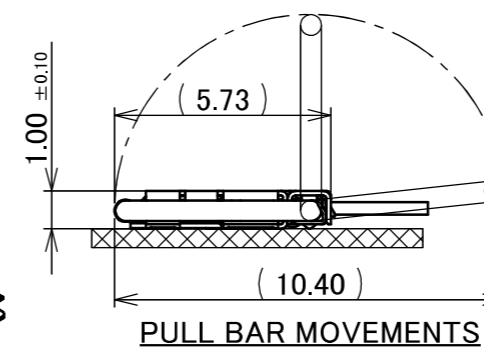
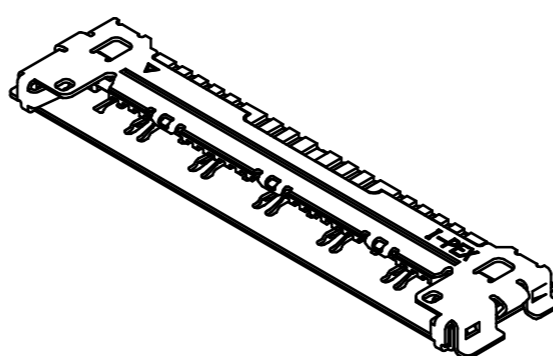
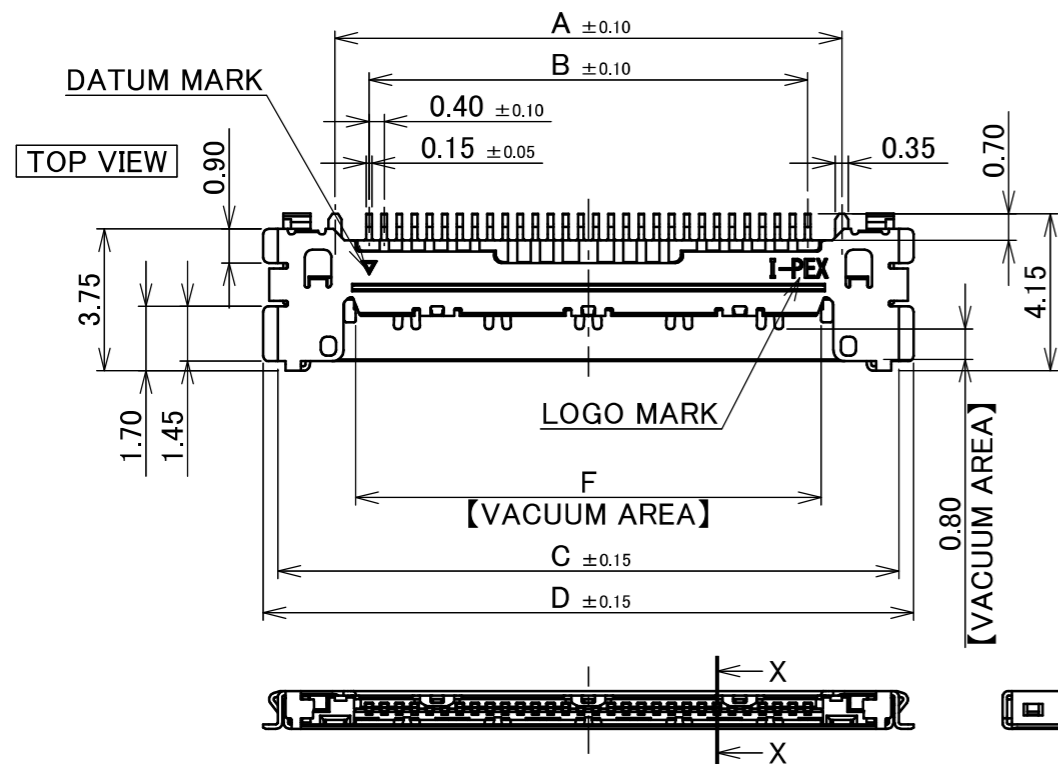

SECT. X-X
(S=20/1)

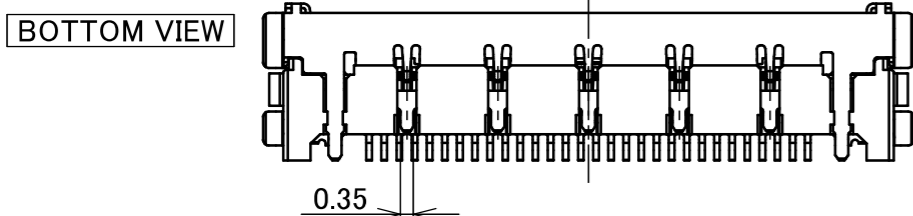
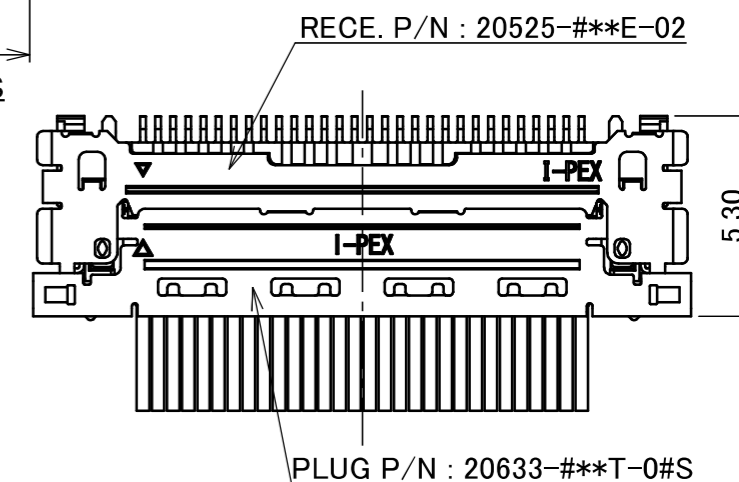

TABLE.1

PART NO.	CONTACT FINISH	SHELL FINISH
20525-0**E-02	CONTACT AREA : Au 0.1 μm MIN. OVER Ni 1.00 μm MIN. SOLDERING AREA : Au 0.03 μm MIN. OVER Ni 1.00 μm MIN.	ALL OVER Au 0.02 μm MIN. OVER Ni 1.00 μm MIN. CONTACT AREA : Au 0.02 μm MIN. OVER Ni 0.80 μm MIN.
20525-2**E-02	CONTACT AREA : Au 0.03 μm MIN. OVER Ni 1.00 μm MIN. SOLDERING AREA : Au 0.03 μm MIN. OVER Ni 1.00 μm MIN.	ALL OVER Ni 1.00 μm MIN. SOLDERING AREA : Au 0.02 μm MIN.

NO.	DISCRIPTION	MATERIAL	FINISH , REMARKS
3	SHELL	PHOSPHOR BRONZE	SEE TABLE 1
2	CONTACT	PHOSPHOR BRONZE	SEE TABLE 1
1	HOUSING	LCP	UL94V-0, BLACK

REV.	ECN	BY	DATE	APP.	APP.	DWG. No.	SHEET	REV.	
32	Z250298	K.Ta	Feb./26/'25	T.M	ANGLE ±2° 6 OVER 30 MAX. ±0.3	PROJECTION SERIES No. R10	CUSTOMER COPY	SCALE 5:1	
31	Z241818	T.Ono	Dec./18/'24	T.M	6 MAX. ±0.2 30 OVER 120 MAX. ±0.5				
30	Z241769	T.Ono	Dec./11/'24	T.M	GENERAL TOLERANCE.				
29	Z241637	H.U	Nov./19/'24	T.M	DWG. T.Kurachi DATE 2009/11/13	TITLE CABLIN®-CA RECEPTACLE ASSEMBLY	UNIT mm	I-PEX	
28	Z231028	H.U	Sept./13/'23	T.M	CHK. Y.Hashimoto				
27	Z230040	K.B	Jan./13/'23	H.I	APP. T.Harada				
REV.	ECN	BY	DATE	APP.	APP.	20525	SIZE A3	SHEET 1/7	REV. 32

PART NO.
20525-***E-02

BOTTOM VIEW

PATENT REGISTERED

10P

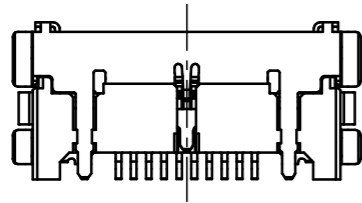

12P

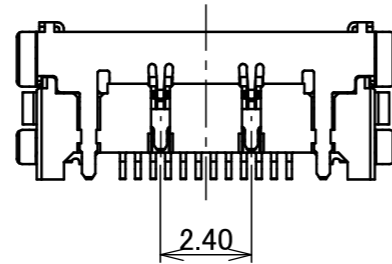

20P

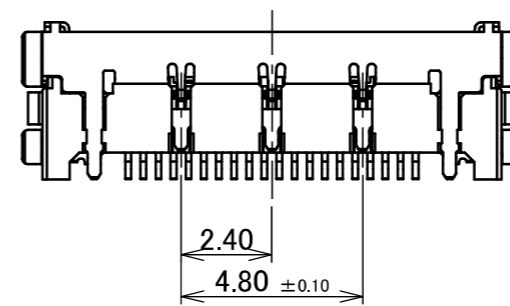

30P

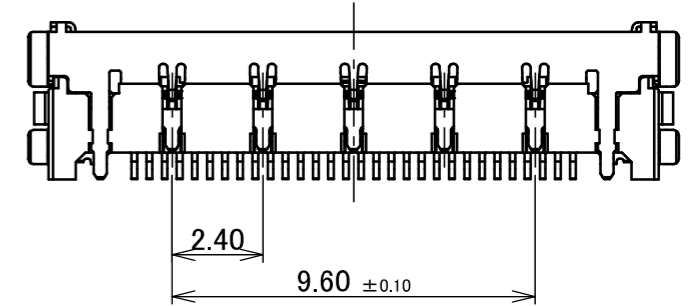

40P

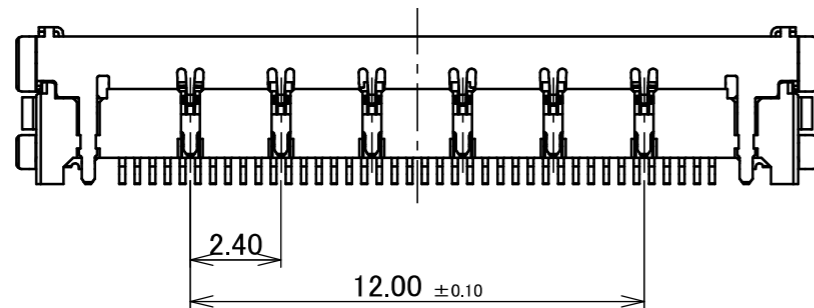

50P

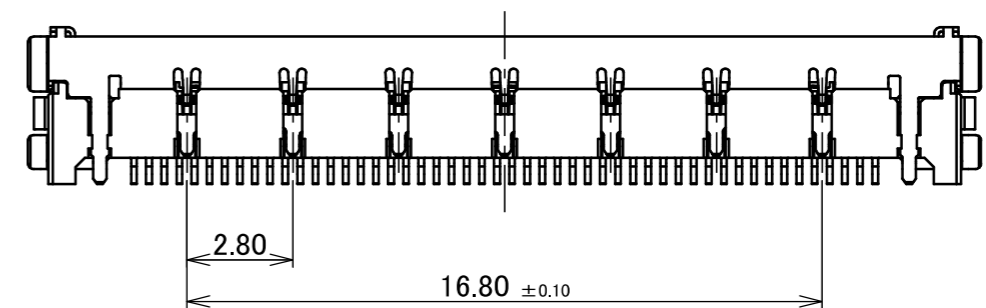

60P

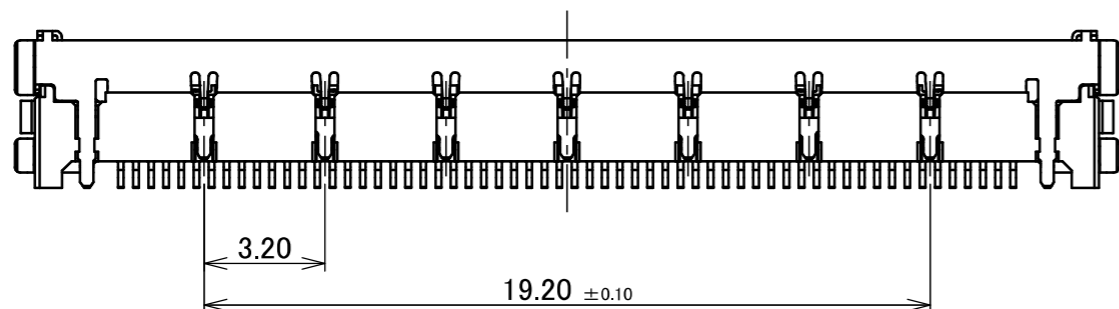

ANGLE	±2°	6 OVER 30 MAX.	±0.3	PROJECTION ⊕	SERIES No. R10	CUSTOMER COPY		
6 MAX.	±0.2	30 OVER 120 MAX.	±0.5					
GENERAL TOLERANCE.				TITLE CABLIN [®] -CA RECEPTACLE ASSEMBLY	SCALE 5:1 UNIT mm	I-PEX		
DWG.	DATE							
CHK.								
APP.								
				DWG. No.	20525	SIZE A3	SHEET 2/7	REV. 32

FOR CABLINE-CA PLUG CABLE ASSEMBLY (DWG NO. 20633)

ITEMS	SPECIFICATION
APPLICABLE CABLE	MICRO-COAXIAL CABLE : AWG# 44 , 42 , 40 , 38 , 36 DISCRETE WIRE : AWG# 36 , 34 TWINAX CABLE : AWG# 40 , 42
RATING VOLTAGE	100V AC (PER CONTACT PIN) ※THIS IS THE RATED VOLTAGE OF THE CONNECTOR. PLEASE NOTE THAT THE RATED VOLTAGE MAY VARY IN THE HARNESS DEPENDING ON THE CABLES USED.
RATING AMPERAGE (FOR CONTACT)	0.1A AC/DC [AWG#44] PER CONTACT PIN/UP TO 60 CONTACTS 0.24A AC/DC [AWG#42] PER CONTACT PIN/UP TO 50 CONTACTS 0.3A AC/DC [AWG#40] PER CONTACT PIN/UP TO 40 CONTACTS 0.5A AC/DC [AWG#38] PER CONTACT PIN/UP TO 14 CONTACTS 0.8A AC/DC [AWG#36] PER CONTACT PIN/UP TO 6 CONTACTS 1.0A AC/DC [AWG#34] PER CONTACT PIN/UP TO 4 CONTACTS ※TESTING BY A REAL MACHINE IS RECOMMENDED BECAUSE TEMPERATURE RISE MAY AFFECTED BY ACTUAL SITUATION.
OPERATING TEMPERATURE	233~358K (-40°C~85°C)
OPERATING HUMIDITY	85% MAX.
CONTACT RESISTANCE	INITIAL : 180mohm MAX. (AWG#34) / AFTER TEST : \triangle 40mohm MAX. 275mohm MAX. (AWG#36) 360mohm MAX. (AWG#38) 600mohm MAX. (AWG#40) 700mohm MAX. (AWG#42) 1080mohm MAX. (AWG#44)
GROUND SHELL RESISTANCE	INITIAL : 50mohm MAX. / AFTER TEST : \triangle 40mohm MAX.
INSULATION RESISTANCE	INITIAL : 1000Mohm MIN. / AFTER TEST : 500Mohm MIN.
DIELECTRIC WITHSTANDING VOLTAGE	AC250V 1min
DURABILITY	30 CYCLES
MATING FORCE (INITIAL / AFTER 30 CYCLES)	10P : 7.80N MAX. 40P : 19.40N MAX. 12P : 8.20N MAX. 50P : 24.25N MAX. 20P : 9.70N MAX. 60P : 29.10N MAX. 30P : 14.55N MAX.
UNMATING FORCE (INITIAL / AFTER 30 CYCLES)	10P : 1.00N MIN. 40P : 4.00N MIN. 12P : 1.20N MIN. 50P : 5.00N MIN. 20P : 2.00N MIN. 60P : 6.00N MIN. 30P : 3.00N MIN.
CABLE RETENTION FORCE	10P : 4.90N MIN. 40P : 19.60N MIN. 12P : 5.88N MIN. 50P : 24.50N MIN. 20P : 9.80N MIN. 60P : 29.40N MIN. 30P : 14.70N MIN.
COPLANARITY	0.10 MAX.
PRODUCT SPECIFICATION	PRS-1968
TEST REPORT	TR-14122 (20525-0**E-0#) / TR-16023 (20525-2**E-0#)
PACKING STANDARD	300-824
INSTRUCTION MANUAL	HIM-09008
APPEARANCE CRITERIA No.	QLS-A***

ANGLE	$\pm 2^\circ$	6 OVER 30 MAX.	± 0.3	PROJECTION 	SERIES No. R10	CUSTOMER COPY		
	6 MAX.	± 0.2	30 OVER 120 MAX.					
GENERAL TOLERANCE.				TITLE CABLINE®-CA RECEPTACLE ASSEMBLY	SCALE mm	I-PEX		
DWG.	DATE							
CHK.								
APP.								
				DWG. No.	20525	SIZE	SHEET	REV.
						A3	3/7	32

FOR CABLINE-CAF PLUG SHELL ASSEMBLY (DWG NO. 20858)

ITEMS	SPECIFICATION
RATING VOLTAGE	100V AC (PER CONTACT PIN)
RATING AMPERAGE (FOR CONTACT)	0.5A AC/DC (PER CONTACT PIN) ※AVAILABLE UP TO 14PIN 0.3A AC/DC (PER CONTACT PIN) ※AVAILABLE FOR ALL PIN ※TESTING BY A REAL MACHINE IS RECOMMENDED BECAUSE TEMPERATURE RISE MAY AFFECTED BY ACTUAL SITUATION.
OPERATING TEMPERATURE	233~358K(-40°C~+85°C)
OPERATING HUMIDITY	85% MAX.
CONTACT RESISTANCE (FOR SIGNAL CONTACT)	INITIAL : 60mohm MAX. / AFTER TEST : \triangleleft 40mohm MAX.
GROUND SHELL RESISTANCE	INITIAL : 60mohm MAX. / AFTER TEST : \triangleleft 40mohm MAX.
INSULATION RESISTANCE	INITIAL : 1000Mohm MIN. / AFTER TEST : 500Mohm MIN.
DIELECTRIC WITHSTANDING VOLTAGE	AC250V 1min
DURABILITY	30 CYCLES
MATING FORCE (INITIAL / AFTER TEST)	40P : 11.07N MAX. 40P : 16.61N MAX.
UNMATING FORCE (INITIAL / AFTER TEST)	30P : 1.44N MIN. 40P : 2.16N MIN.
COPLANARITY	0.10 MAX.
PRODUCT SPECIFICATION	PRS-2465
TEST REPORT	TR-18016
PACKING STANDARD	300-824
INSTRUCTION MANUAL	HIM-18016
APPEARANCE CRITERIA NO.	QLS-A***

ANGLE	$\pm 2^\circ$	6 OVER 30 MAX.	± 0.3	PROJECTION 	SERIES No. R10	CUSTOMER COPY		
6 MAX.	± 0.2	30 OVER 120 MAX.	± 0.5					
GENERAL TOLERANCE.				TITLE CABLINE®-CA RECEPTACLE ASSEMBLY	SCALE	I-PEX		
DWG.	DATE							
CHK.								
APP.								
DWG. No.	20525			SIZE	SHEET	REV.		
				A3	4/7	32		

PART NO.	POS.	A	B	E	G	H	J	K
20525-#10E-02	10	5.40	3.60	-	8.18	9.60	11.60	-
20525-#12E-02	12	6.20	4.40	2.40	8.98	10.40	12.40	-
20525-#20E-02	20	9.40	7.60	4.80	12.18	13.60	15.60	2.40
20525-#30E-02	30	13.40	11.60	9.60	16.18	17.60	19.60	2.40
20525-#40E-02	40	17.40	15.60	12.00	20.18	21.60	23.60	2.40
20525-#50E-02	50	21.40	19.60	16.80	24.18	25.60	27.60	2.80
20525-#60E-02	60	25.40	23.60	19.20	28.18	29.60	31.60	3.20

PATENT REGISTERED

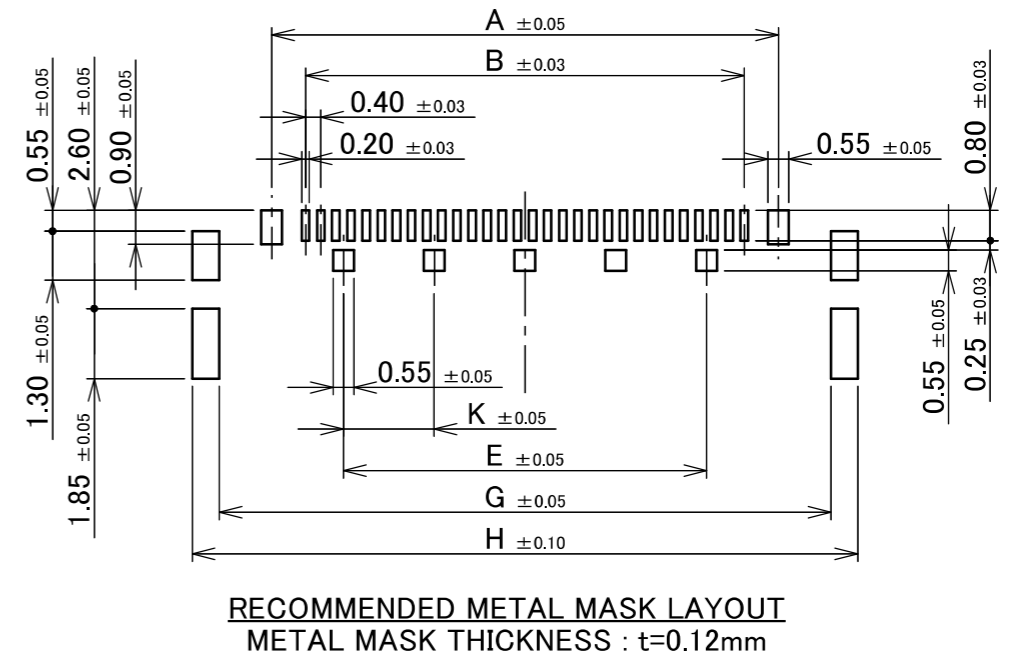
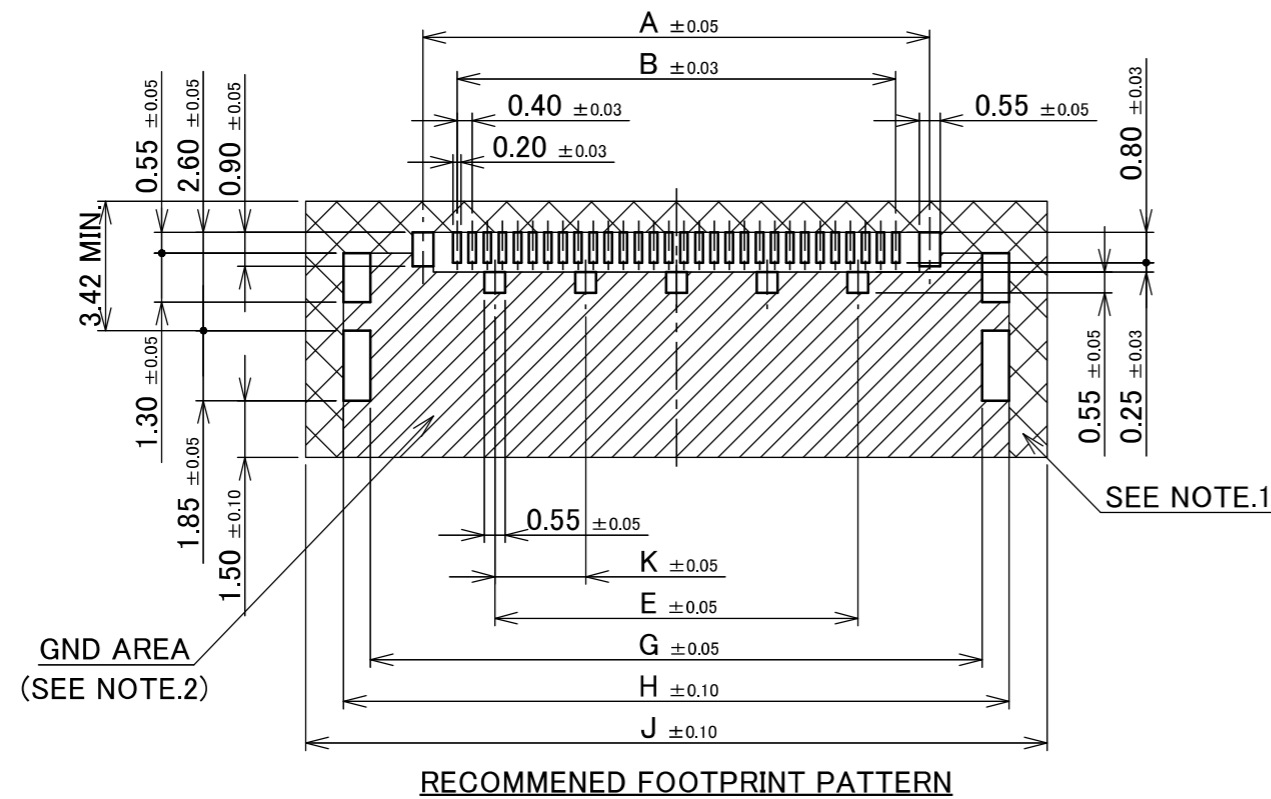

- NOTES.
1. IN CASE OF PLUG WITH PULL BAR(20633-#**T-01S), DO NOT MOUNT ANOTHER COMPONENT IN THIS AREA.
 2. SOLDER RESIST MUST BE APPLIED TO THIS AREA.

ANGLE	±2°	6 OVER 30 MAX.	±0.3	PROJECTION ⊕	SERIES No. R10	CUSTOMER COPY		
6 MAX.	±0.2	30 OVER 120 MAX.	±0.5					
GENERAL TOLERANCE.				TITLE CABLIN [®] -CA RECEPTACLE ASSEMBLY	SCALE 5:1 UNIT mm	I-PEX		
DWG.	DATE							
CHK.								
APP.								
				DWG. No.	20525	SIZE A3	SHEET 5/7	REV. 32

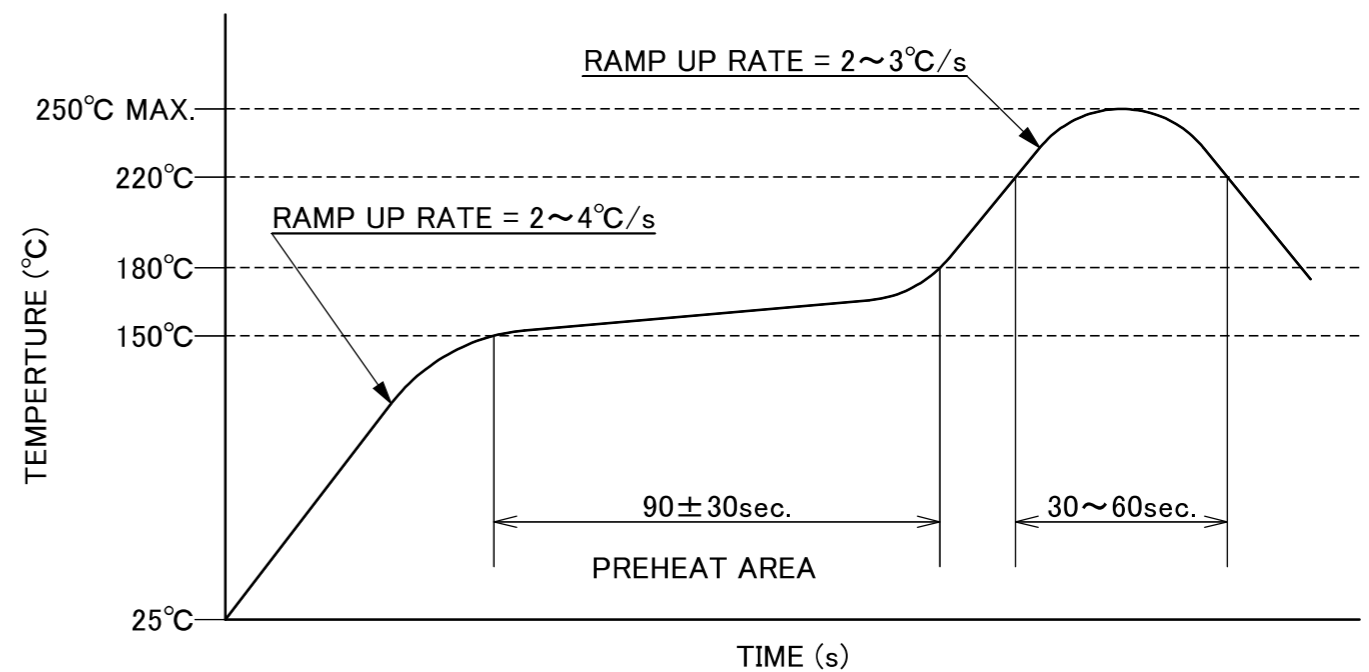
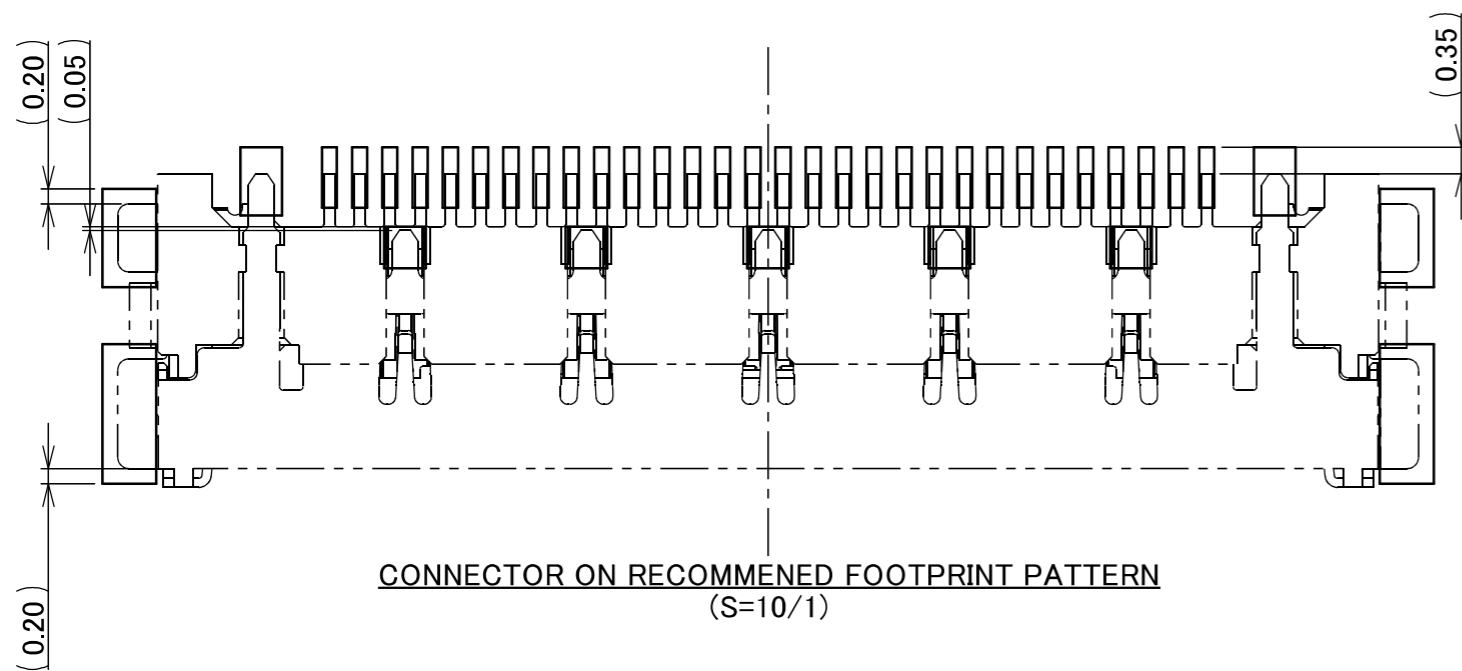

REFLOW TEMPERATURE PROFILE
SENJU METAL INDUSTRY CO., LTD. : M705-SHF(Sn96.5 Ag3.0 Cu0.5)

ANGLE	±2°	6 OVER 30 MAX.	±0.3	PROJECTION ⊕	SERIES No. R10	CUSTOMER COPY				
6 MAX.	±0.2	30 OVER 120 MAX.	±0.5							
GENERAL TOLERANCE.				TITLE CABLIN [®] -CA RECEPTACLE ASSEMBLY		SCALE	I-PEX			
DWG.	DATE					5:1				
CHK.						UNIT				mm
APP.						SIZE				SHEET
				DWG. No.	20525	A3	6/7	32		

PART NO.	M	N	P	Q	R	S	T	REEL QTY.	QTY. IN EMBOSS TAPE (1 REEL)	QTY. IN PACKING CARTON (1 CARTON)
20525-#10E-02	6.35	5.80	8.00	9.60	11.50	-	24.00	5 REELS	5000	5000 × 5 = 25000
20525-#12E-02	7.15	6.60	8.80	10.40	11.50	-	24.00			
20525-#20E-02	10.35	9.80	12.00	13.60	11.50	-	24.00			
20525-#30E-02	14.35	13.80	16.00	17.60	14.20	28.40	32.00	4 REELS	5000	5000 × 4 = 20000
20525-#40E-02	18.35	17.80	20.00	21.60	14.20	28.40	32.00			
20525-#50E-02	22.35	21.80	24.00	25.60	20.20	40.40	44.00	3 REELS	5000	5000 × 3 = 15000
20525-#60E-02	26.35	25.80	28.00	29.60	20.20	40.40	44.00			

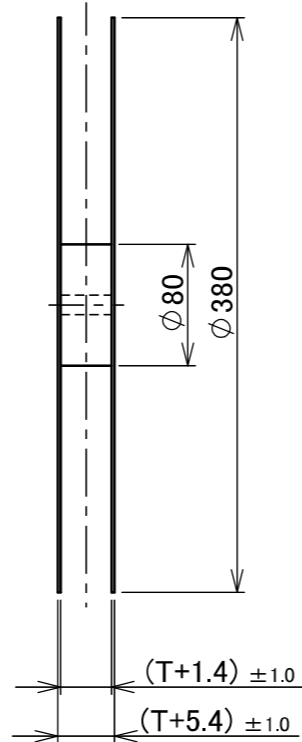
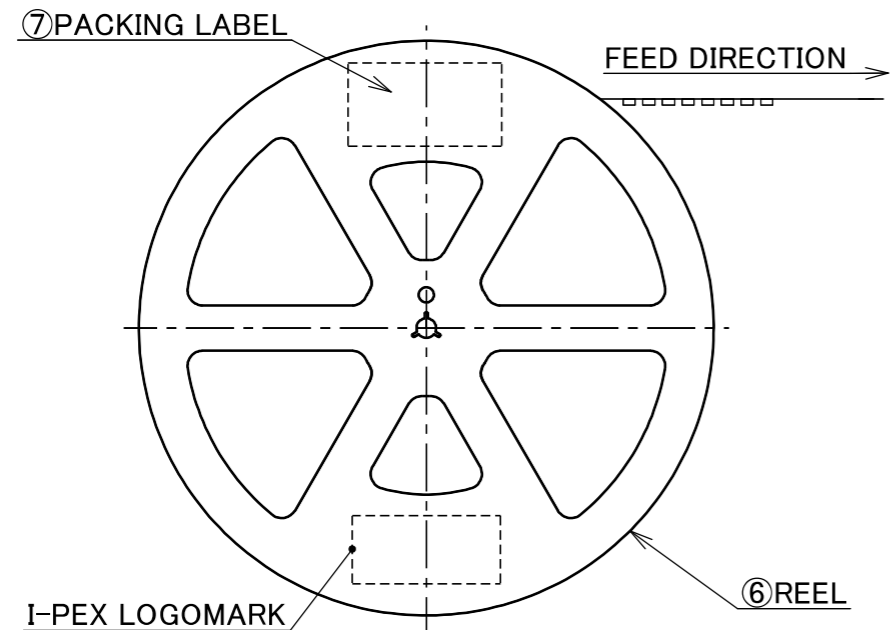

P/N : 20525- # ** E- 0 2
 POS. SEE TABLE 1 (SHEET1/7)

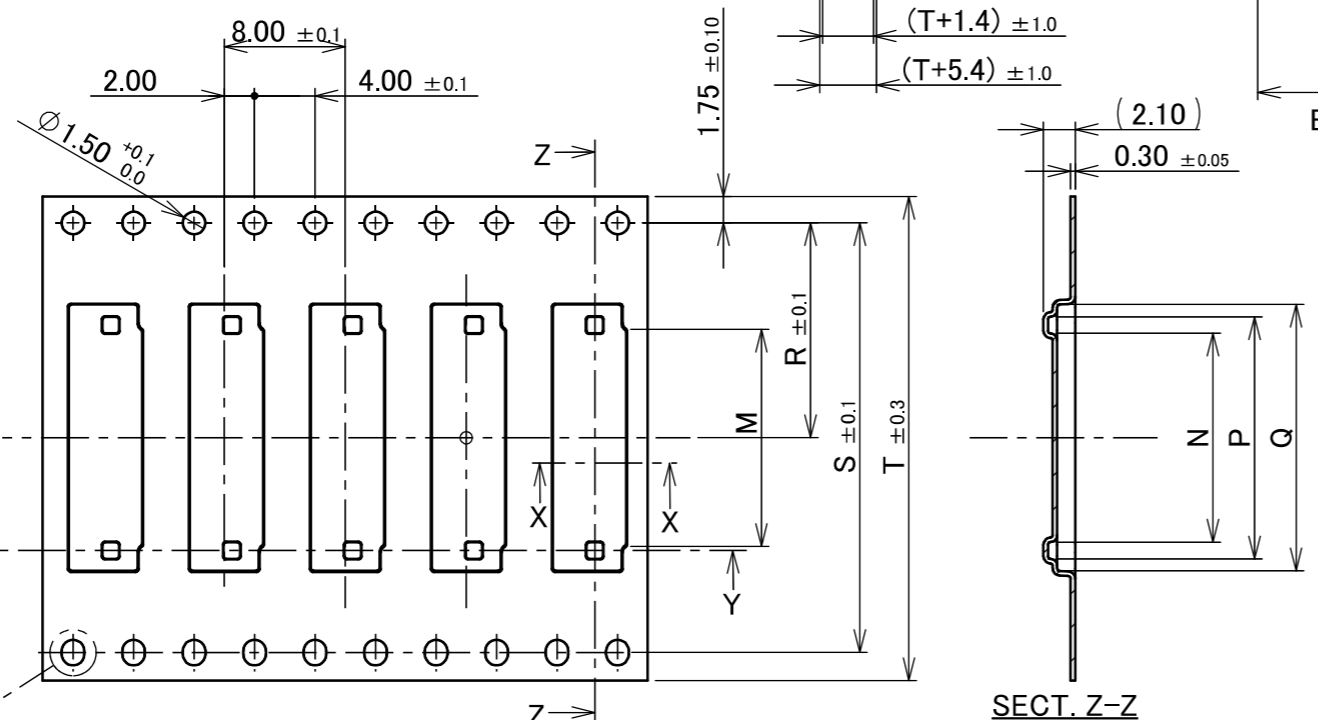
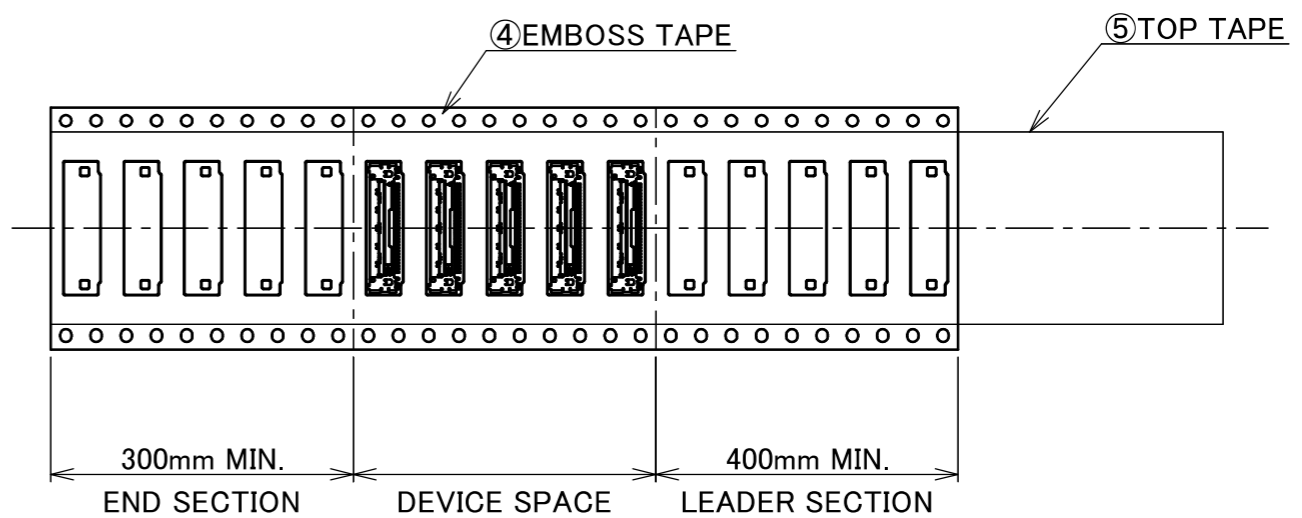

- NOTES.
 3. TAPING SPECIFICATION FOLLOWS JIS C 0806 (IEC 60286-3).
 4. MAKE EMPTY SECTION OF LEADER AND END ON EACH END OF THE TAPE.
 5. TOP TAPE SHALL NOT STICK OUT FROM EMBOSS TAPE.
 6. TOP TAPE SHALL NOT COVER FEED HOLE.

NO.	DISCRIPTION	MATERIAL	FINISH , REMARKS
7	PACKING LABEL	-	-
6	REEL	PS	BLACK
5	TOP TAPE	PET t=0.061 TRANSPARENCY	ANTI-STATIC TYPE ADHESIVE TYPE
4	EMBOSS TAPE	PS t=0.30 TRANSPARENCY	ANTI-STATIC TYPE

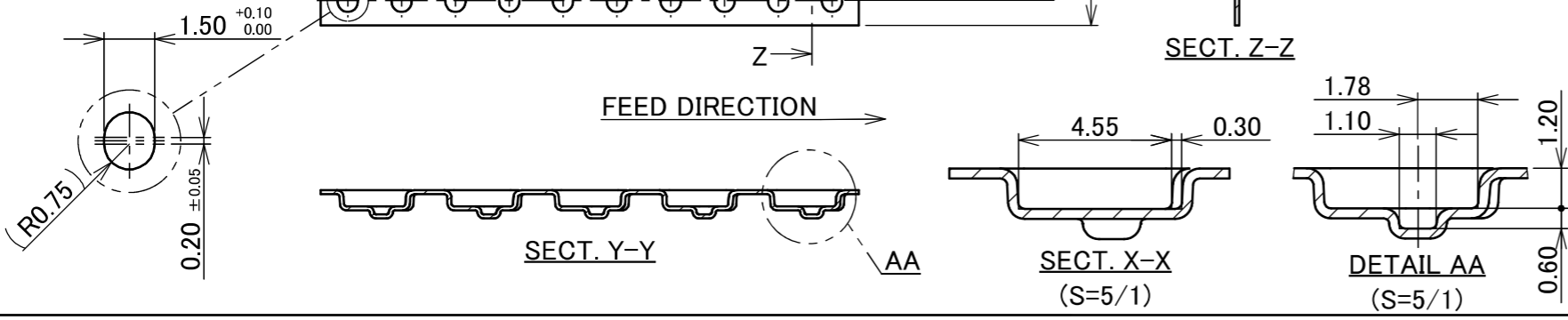

ANGLE	±2°	6 OVER 30 MAX.	±0.3	PROJECTION	SERIES No.	CUSTOMER COPY			
6 MAX.	±0.2	30 OVER 120 MAX.	±0.5		R10	SCALE	I-PEX		
GENERAL TOLERANCE.						TITLE			
DWG.	DATE			CABLINER [®] -CA RECEPTACLE ASSEMBLY		UNIT	mm		
CHK.				DWG. No. 20525		SIZE	SHEET	REV.	
APP.						A3	7/7	32	