

Recommended P/N 20682-0\*\*E-02

PART NO.	Pos.	A	B	C	D	E	J	K	L	U
20682-020E-02	20	9.40	7.60	12.43	13.20	4.80	2.40	5.60	2.00	10.01
20682-030E-02	30	13.40	11.60	16.43	17.20	9.60	2.40	12.00	1.60	14.01
20682-040E-02	40	17.40	15.60	20.43	21.20	12.00	2.40	14.40	1.60	18.01
20682-050E-02	50	21.40	19.60	24.43	25.20	16.80	2.80	18.40	1.60	22.01

P/N : 20682-0 \*\* E- 02  
Pos.



Halogen Free



RoHS Compliant

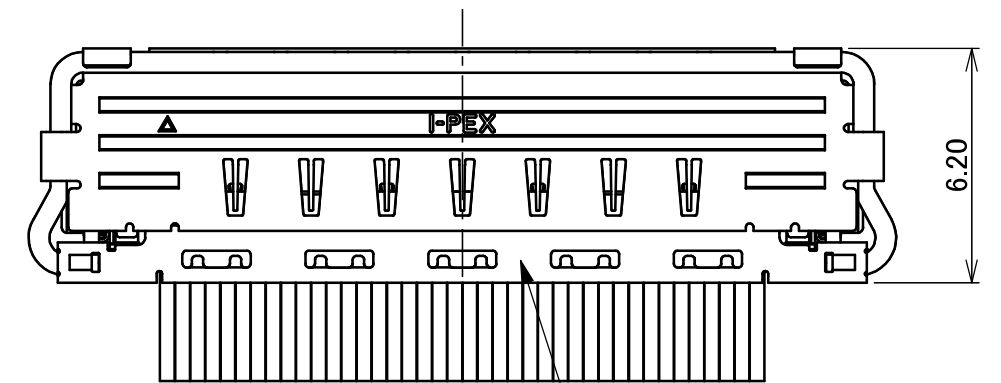
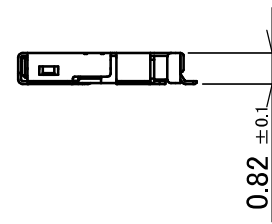
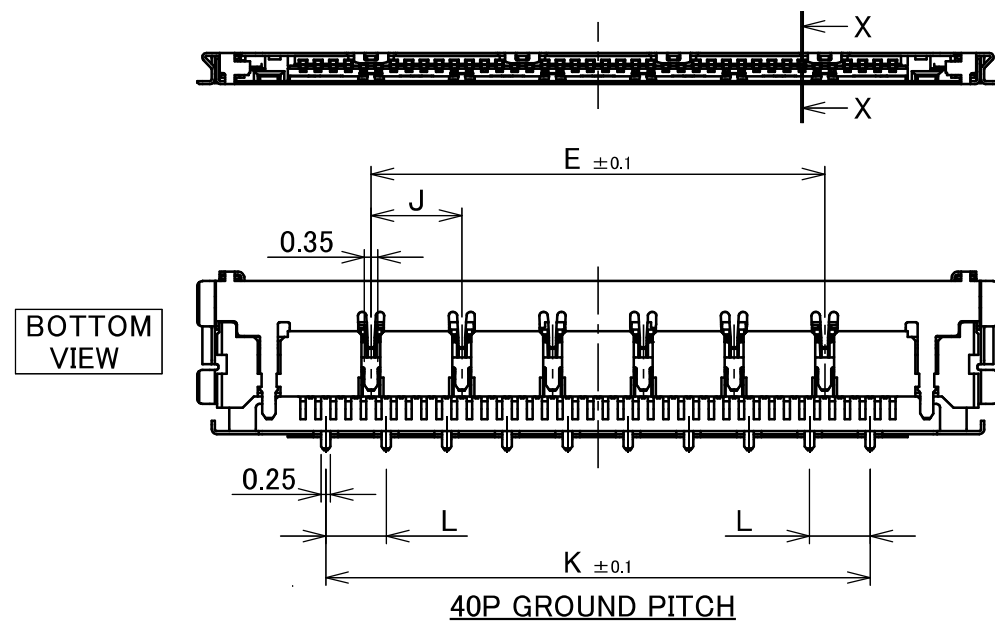
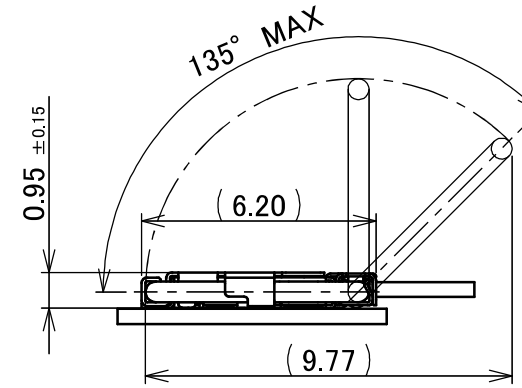
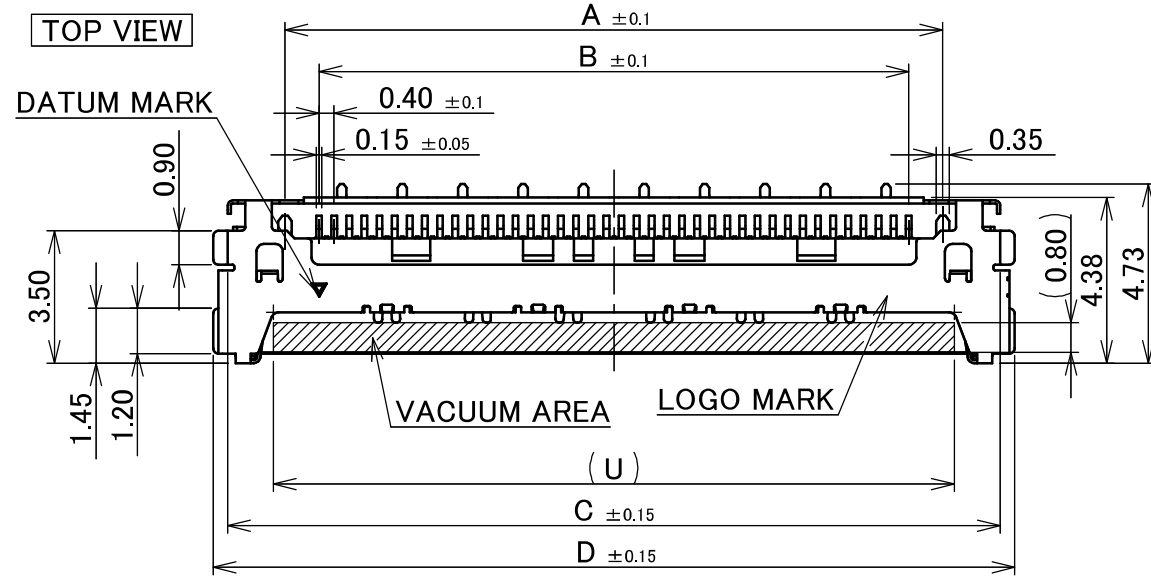
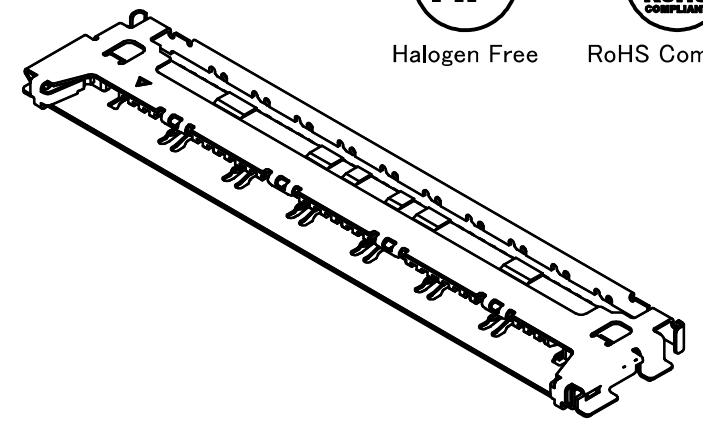

MATING CONDITION

NO.	DISCRIPTION	MATERIAL	FINISH , REMARKS
3	SHELL	PHOSPHOR BRONZE	ALL OVER Ni 1.00 μ m MIN. SOLDERING AREA : Au 0.03 μ m MIN.
2	CONTACT	PHOSPHOR BRONZE	ALL OVER Ni 1.00 μ m MIN. CONTACT & SOLDERING AREA : Au 0.03 μ m MIN.
1	HOUSING	LCP	UL94V-0 ,BLACK

REV.	ECN	BY	DATE	APP.	APP.	DATE	DWG. No.	SIZE	SHEET	REV.
16	Z250425	K.Hara	Mar./13/'25	H.I	ANGLE	±2°	6 OVER 30 MAX.	±0.3		
15	Z241785	K.Hara	Dec./13/'24	H.I	6 MAX.	±0.2	30 OVER 120 MAX.	±0.5		
14	Z241093	K.Hara	Aug./20/'24	H.I	GENERAL TOLERANCE.					
13	Z240029	K.Hara	Jan./12/'24	H.I	DWG.	T.Masunaga	DATE	2015/03/24		
12	Z230042	K.B	Jan./13/'23	H.I	CHK.	J.Tateishi	DATE	2015/03/24		
11	Z220151	K.Hara	Feb./14/'22	H.I	APP.	E.Kawabe	DATE	2015/03/25		

**PATENT REGISTERED**

PART NO.	Pos.	E	J	K	L
20682-020E-02	20	4.80	2.40	5.60	2.00
20682-030E-02	30	9.60	2.40	12.00	1.60
20682-040E-02	40	12.00	2.40	14.40	1.60
20682-050E-02	50	16.80	2.80	18.40	1.60

# PATENT REGISTERED

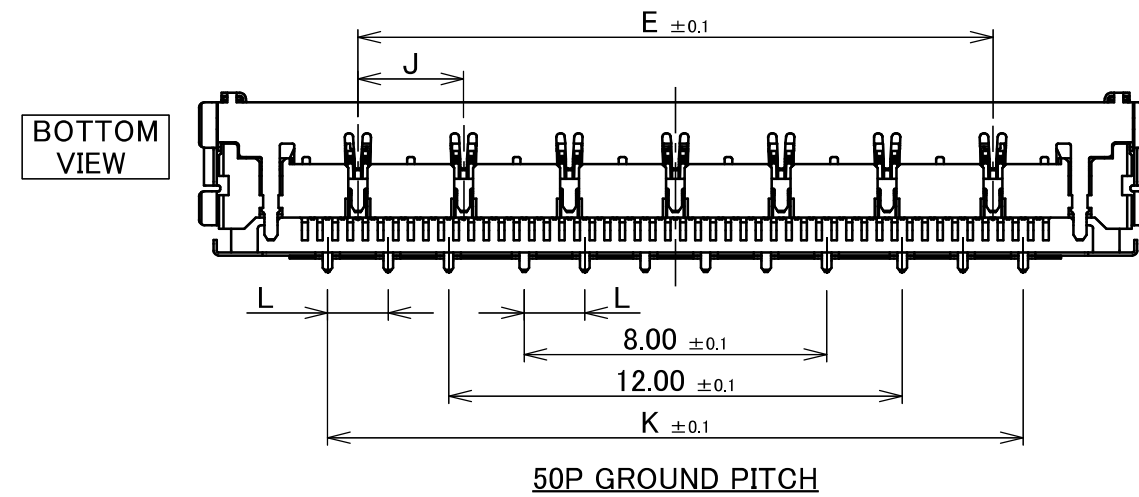
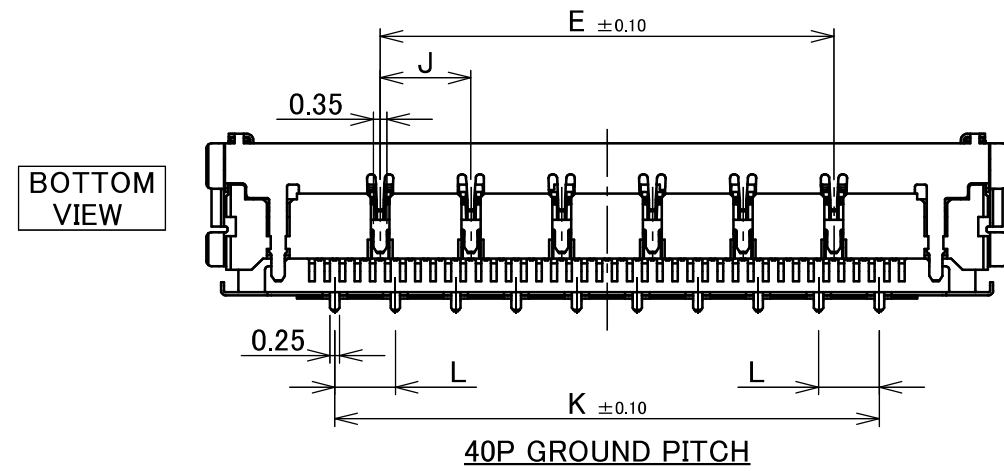
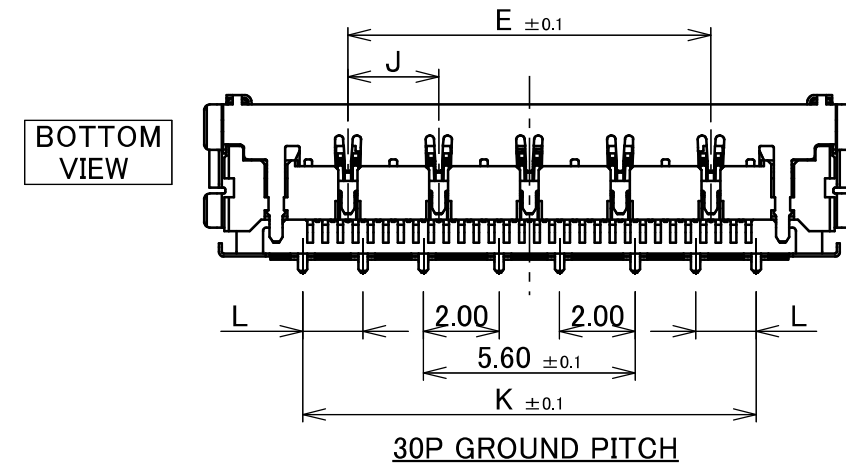
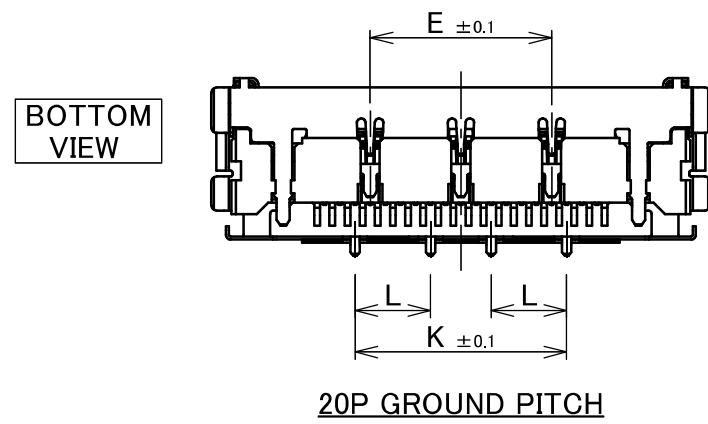

ANGLE	±2°	6 OVER 30 MAX.	±0.3	PROJECTION ⊕	SERIES No. R1	CUSTOMER COPY		
	6 MAX.	±0.2	30 OVER 120 MAX.					±0.5
GENERAL TOLERANCE.				TITLE CABLIN <sup>®</sup> -CA II RECEPTACLE ASSEMBLY	SCALE 5:1 UNIT mm	<b>I-PEX</b>		
DWG.	DATE							
CHK.								
APP.								
				DWG. No.	20682	SIZE A3	SHEET 2/8	REV. 16

FOR CABLINE-CA II PLUG CABLE ASSEMBLY (DWG. NO. 20679)

ITEMS	SPECIFICATION
APPLICABLE CABLE	MICRO-COAXIAL : AWG# 44 , 42 , 40 , 38 , 36 DISCRETE WIRE : AWG# 36 , 34 TWINAX CABLE : AWG# 40 , 42
RATING VOLTAGE	100V AC (PER CONTACT PIN) ※THIS IS THE RATED VOLTAGE OF THE CONNECTOR. PLEASE NOTE THAT THE RATED VOLTAGE MAY VARY IN THE HARNESS DEPENDING ON THE CABLES USED.
RATING AMPERAGE (FOR CONTACT)	0.1A AC/DC [AWG#44] PER CONTACT PIN/UP TO 50 CONTACTS 0.24A AC/DC [AWG#42] PER CONTACT PIN/UP TO 50 CONTACTS 0.3A AC/DC [AWG#40] PER CONTACT PIN/UP TO 50 CONTACTS 0.5A AC/DC [AWG#38] PER CONTACT PIN/UP TO 18 CONTACTS 0.8A AC/DC [AWG#36] PER CONTACT PIN/UP TO 6 CONTACTS 1.0A AC/DC [AWG#34] PER CONTACT PIN/UP TO 6 CONTACTS ※TESTING BY A REAL MACHINE IS RECOMMENDED BECAUSE TEMPERTURE RISE MAY AFFECTED BY ACTUAL SITUATION.
OPERATING TEMPERATURE	233~378K(-40°C~105°C)
OPERATING HUMIDITY	85% MAX.(NON-CONDENDING)
CONTACT RESISTANCE	INITIAL : 180mohm MAX.(AWG#34) / AFTER TEST : $\triangle$ 40mohm MAX. 275mohm MAX.(AWG#36) 360mohm MAX.(AWG#38) 600mohm MAX.(AWG#40) 700mohm MAX.(AWG#42) 1080mohm MAX.(AWG#44)
GROUND SHELL RESISTANCE	INITIAL : 50mohm MAX. / AFTER TEST : $\triangle$ 40mohm MAX.
INSULATION RESISTANCE	INITIAL : 1000Mohm MIN. / AFTER TEST : 500Mohm MIN.
DIELECTRIC WITHSTANDING VOLTAGE	AC250V 1min
DURABILITY	30 CYCLES
MATING FORCE (INITIAL / AFTER 30 CYCLES)	20P : 9.70N MAX. 30P : 14.55N MAX. 40P : 19.40N MAX. 50P : 24.25N MAX.
UN-MATING FORCE (INITIAL / AFTER 30 CYCLES)	20P : 2.0N MIN. 30P : 3.0N MIN. 40P : 4.0N MIN. 50P : 5.0N MIN.
CABLE RETENTION FORCE	20P : 9.80N MIN. 30P : 14.55N MIN. 40P : 19.40N MIN. 50P : 24.25N MIN.
COPLANARITY	0.10 MAX.
PRODUCT SPECIFICATION	PRS-2163
TEST REPORT	TR-15103
INSTRUCTION MANUAL	HIM-15033
PACKING STANDARD	PST-15027
APPEARANCE CRITERIA No.	QLS-A***

ANGLE	$\pm 2^\circ$	6 OVER 30 MAX.	$\pm 0.3$	PROJECTION 	SERIES No. R1	CUSTOMER COPY			
		6 MAX.	$\pm 0.2$			30 OVER 120 MAX.	$\pm 0.5$	SCALE	5:1
GENERAL TOLERANCE.				TITLE		UNIT	I-PEX		
DWG.	DATE			CABLINE® -CA II RECEPTACLE ASSEMBLY		mm			
CHK.						SIZE	SHEET	REV.	
APP.				DWG. No. 20682		A3	3/8	16	

FOR CABLINE-CA IIF PLUG SHELL ASSEMBLY (DWG. NO. 20856)

ITEMS	SPECIFICATION
RATING VOLTAGE	100V AC (PER CONTACT PIN)
RATING AMPERAGE (FOR SIGNAL CONTACT)	0.3A AC/DC (PER CONTACT PIN) ※TESTING BY A REAL MACHINE IS RECOMMENDED BECAUSE TEMPERATURE RISE MAY AFFECTED BY ACTUAL SITUATION.
OPERATING TEMPERATURE	233~358K(-40°C~+85°C)
OPERATING HUMIDITY	85% MAX.(NON-CONDENSING)
CONTACT RESISTANCE (FOR SIGNAL CONTACT)	INITIAL : 60mohm MAX. / AFTER TEST : $\triangle$ 40mohm MAX.
GROUND SHELL RESISTANCE	INITIAL : 60mohm MAX. / AFTER TEST : $\triangle$ 40mohm MAX.
INSULATION RESISTANCE	INITIAL : 1000Mohm MIN. / AFTER TEST : 500Mohm MIN.
DIELECTRIC WITHSTANDING VOLTAGE	AC250V 1min
DURABILITY	30 CYCLES
MATING FORCE (INITIAL / AFTER TEST)	30P : 13.5N MAX. 40P : 18.0N MAX. 50P : 22.5N MAX.
UNMATING FORCE (INITIAL / AFTER TEST)	30P : 1.44N MIN. 40P : 1.92N MIN. 50P : 2.40N MIN.
PRODUCT SPECIFICATION	PRS-2418
TEST REPORT	TR-17079
PACKING STANDARD	PST-17104
INSTRUCTION MANUAL	HIM-17029
ASSEMBLY MANUAL	ASM-17006
APPEARANCE CRITERIA No.	QLS-A***

ANGLE	$\pm 2^\circ$	6 OVER 30 MAX.	$\pm 0.3$	PROJECTION 	SERIES No. R1	CUSTOMER COPY		
6 MAX.	$\pm 0.2$	30 OVER 120 MAX.	$\pm 0.5$					
GENERAL TOLERANCE.				TITLE CABLINE® -CA II RECEPTACLE ASSEMBLY	SCALE 5:1 UNIT mm			
DWG.	DATE							
CHK.								
APP.								
				DWG. No.	20682	SIZE A3	SHEET 4/8	REV. 16

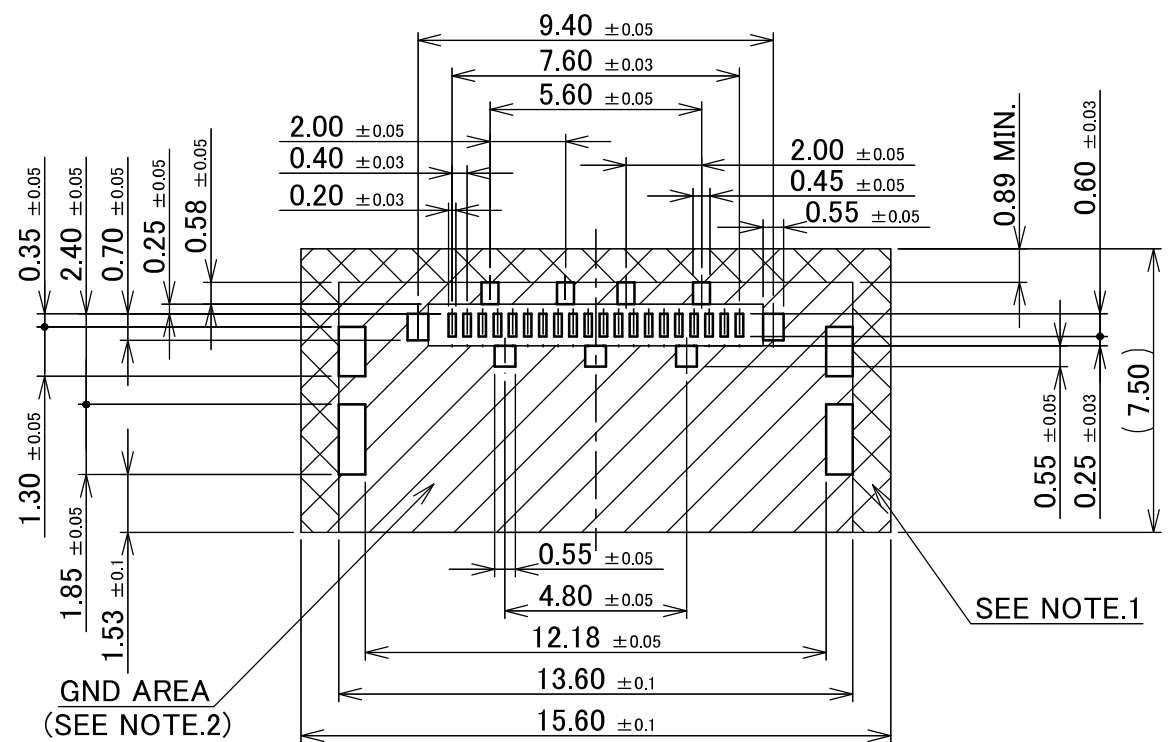

**20P RECOMMENDED FOOTPRINT PATTERN LAYOUT**

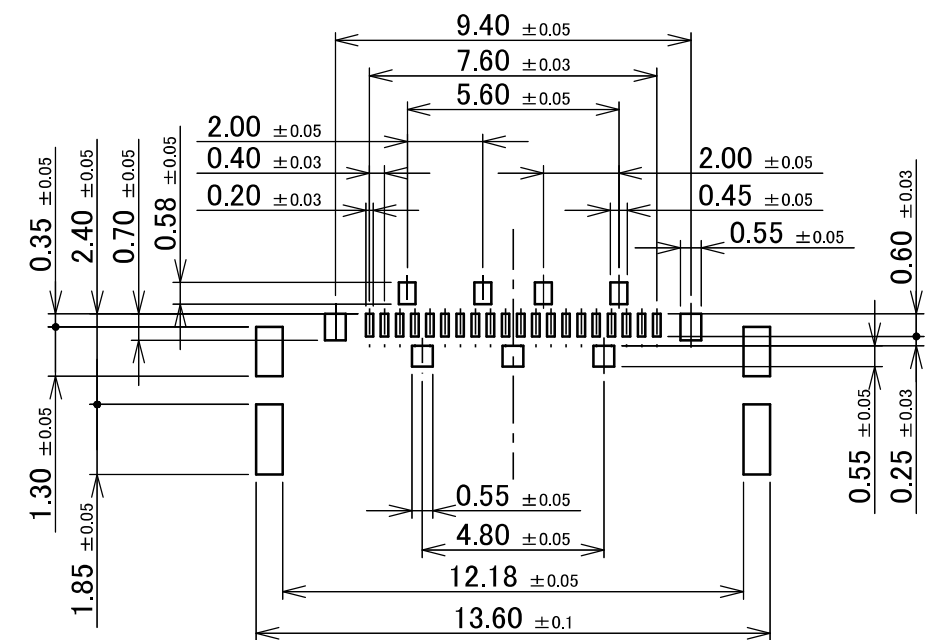

**20P RECOMMENDED METAL MASK LAYOUT**  
METAL MASK THICKNESS : t=0.12mm

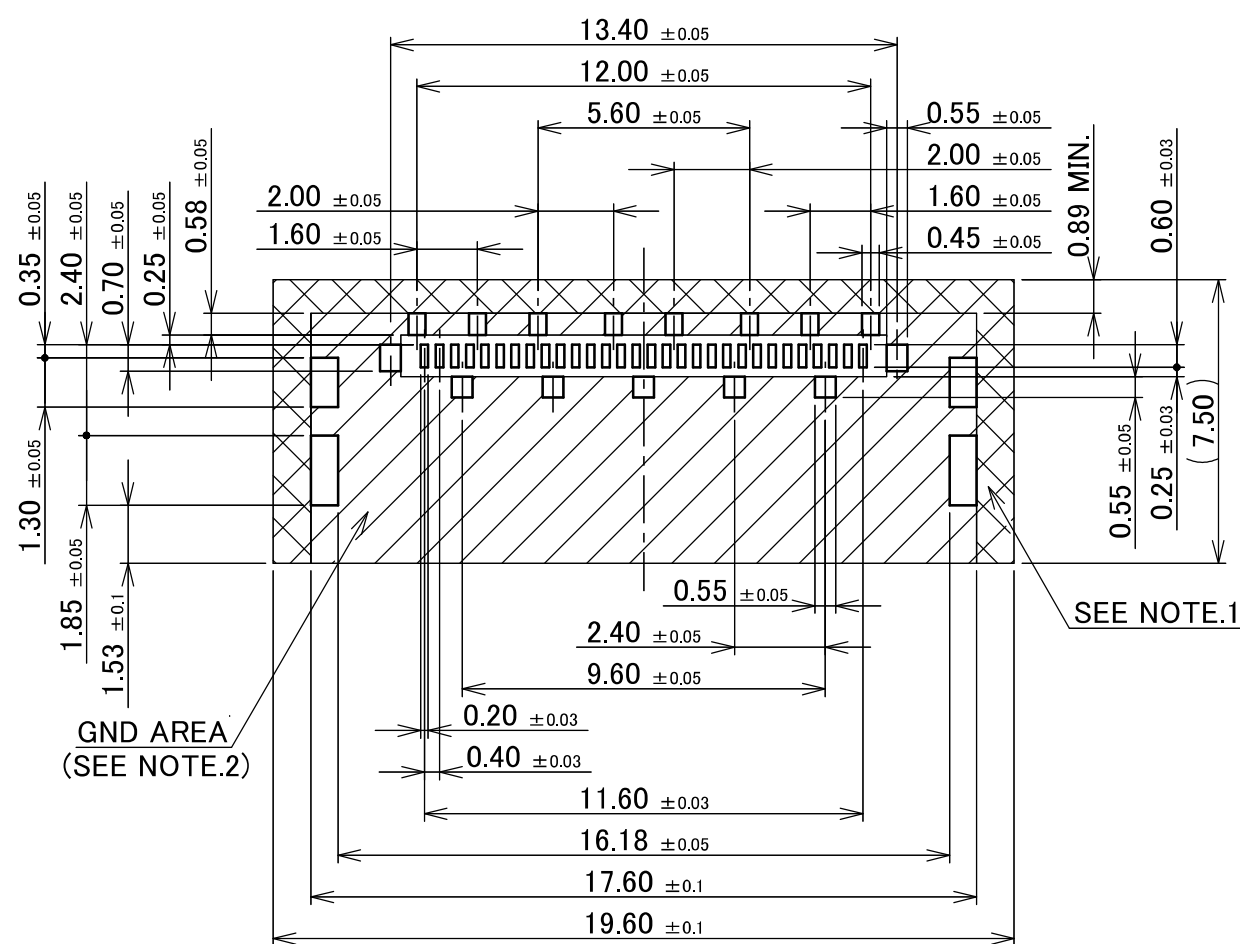

**30P RECOMMENDED FOOTPRINT PATTERN LAYOUT**

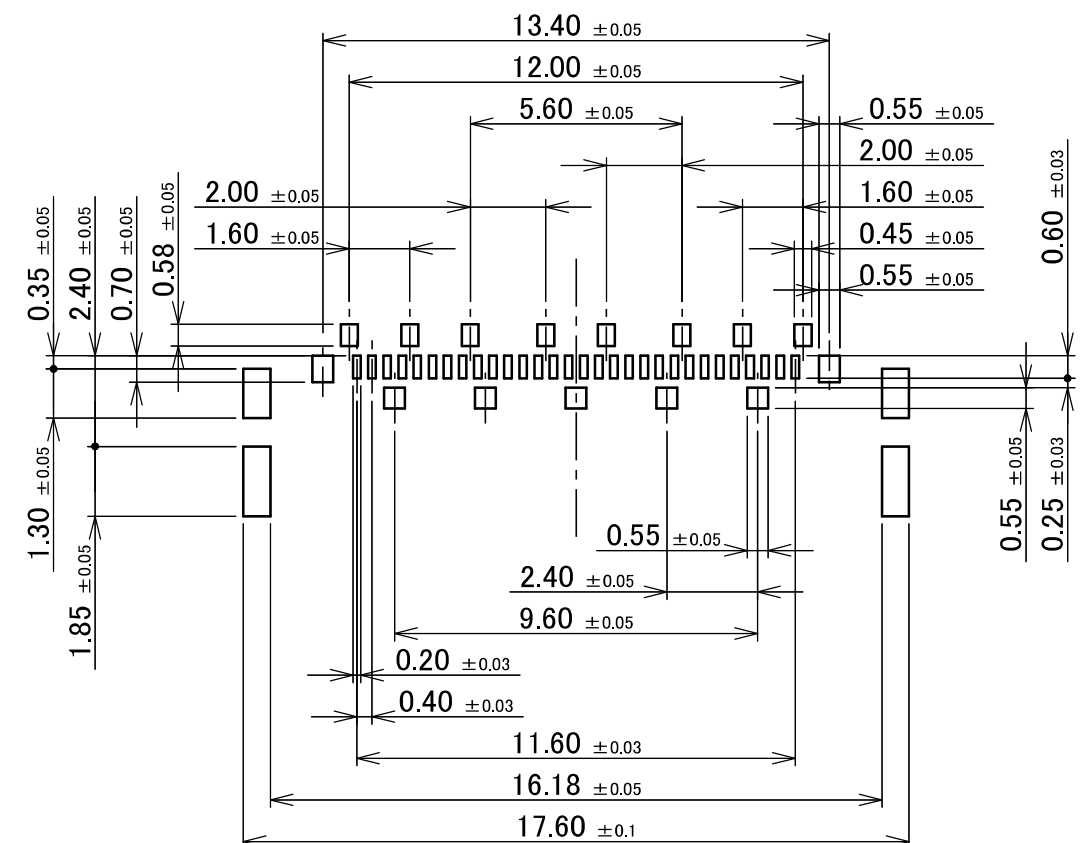

**30P RECOMMENDED METAL MASK LAYOUT**  
METAL MASK THICKNESS : t=0.12mm

- NOTES.  
 1. DO NOT MOUNT ANOTHER COMPONENT IN THIS AREA.  
 2. SOLDER RESIST MUST BE APPLIED TO THIS AREA.

ANGLE	±2°	6 OVER 30 MAX.	±0.3	PROJECTION	SERIES No.	CUSTOMER COPY	
					R1		
6 MAX.	±0.2	30 OVER 120 MAX.	±0.5	GENERAL TOLERANCE.	TITLE	SCALE	<b>I-PEX</b>
DWG.	DATE				CABLINE® -CA II RECEPTACLE ASSEMBLY	5:1	
CHK.						UNIT	
APP.						mm	
				DWG. No.	20682	SIZE	SHEET
						A3	5/8
							REV.
							16

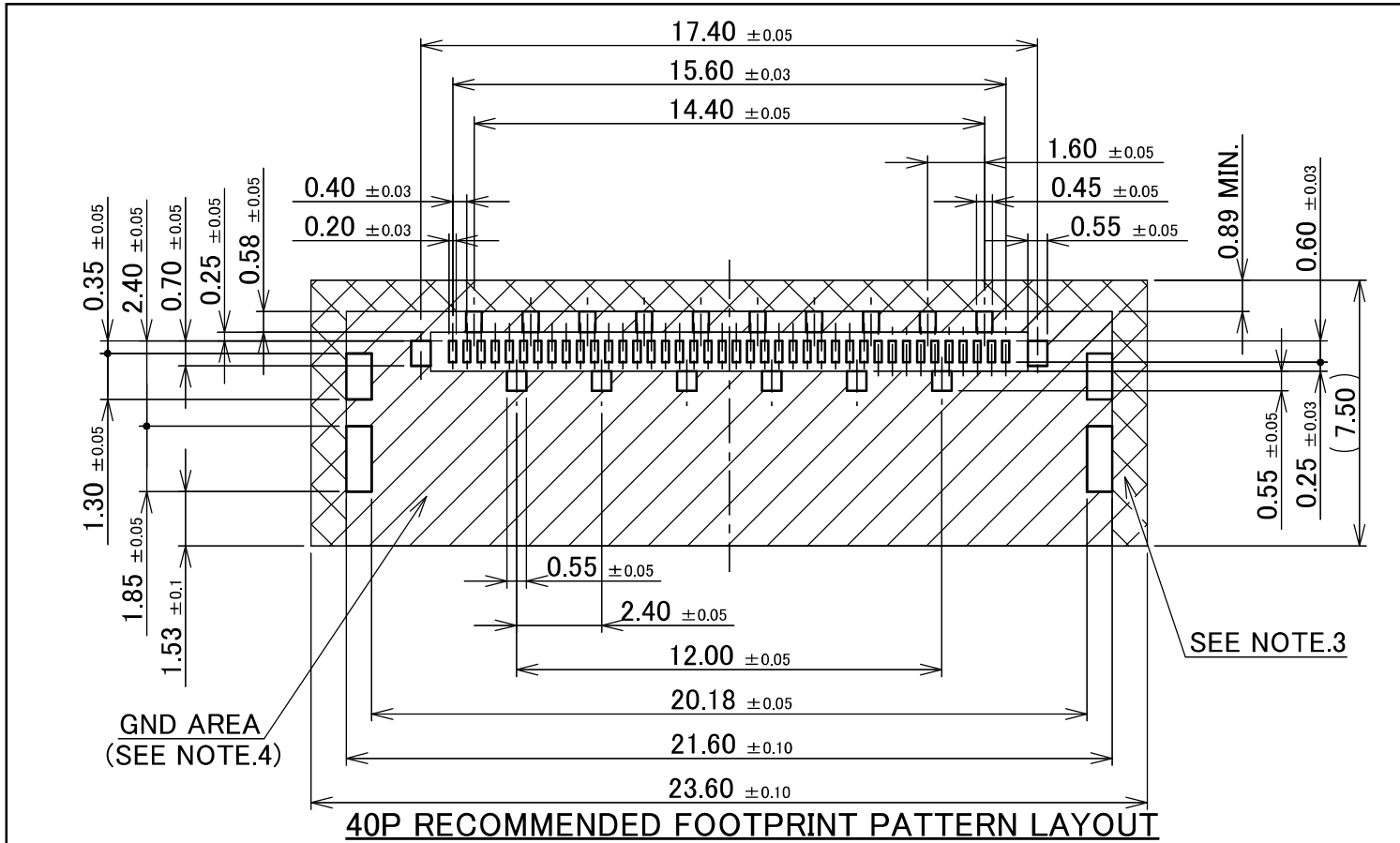

**40P RECOMMENDED FOOTPRINT PATTERN LAYOUT**

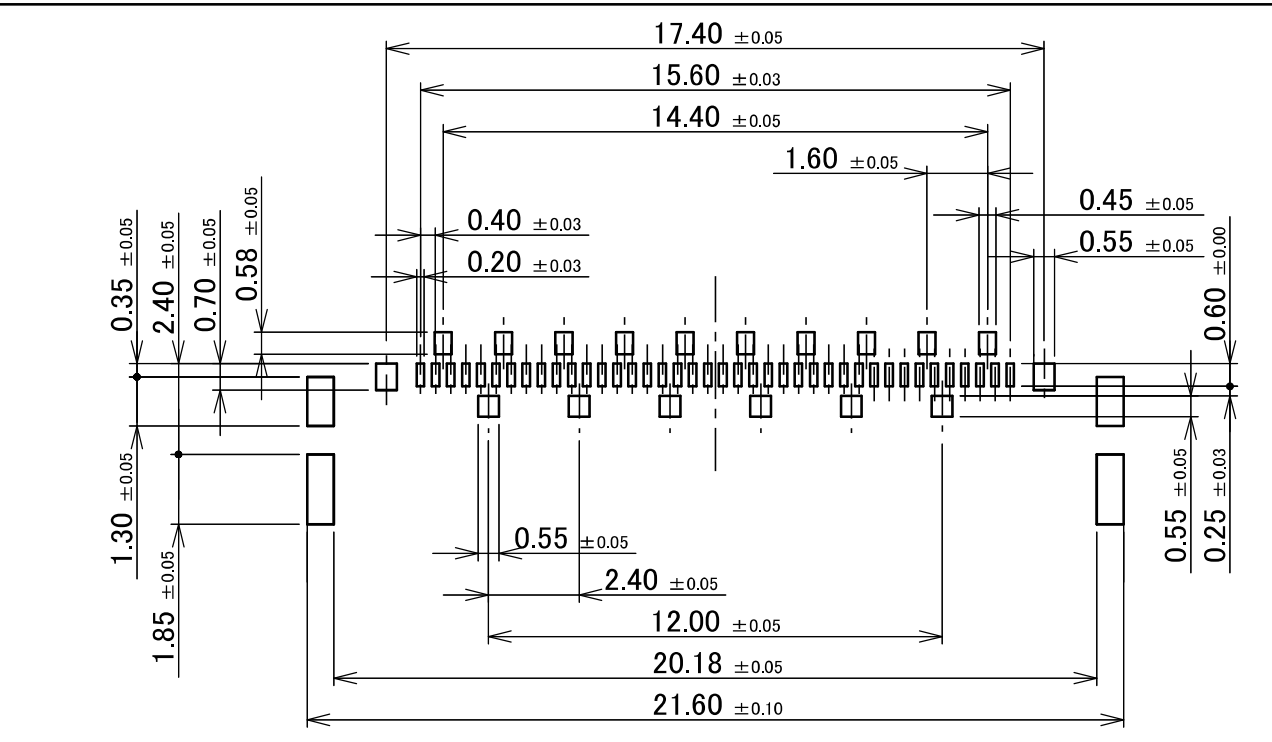

**40P RECOMMENDED METAL MASK LAYOUT  
METAL MASK THICKNESS : t=0.12mm**

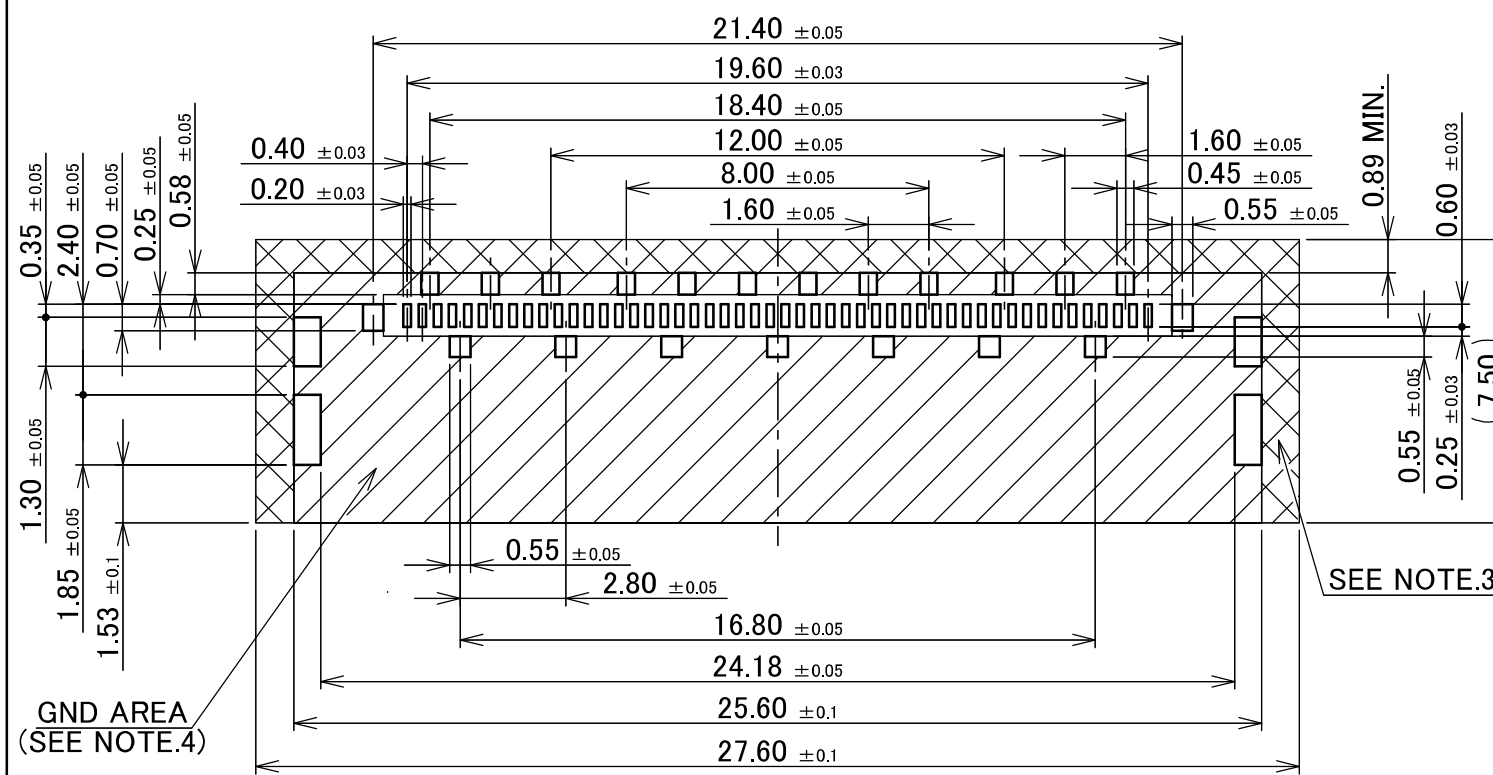

**50P RECOMMENDED FOOTPRINT PATTERN LAYOUT**

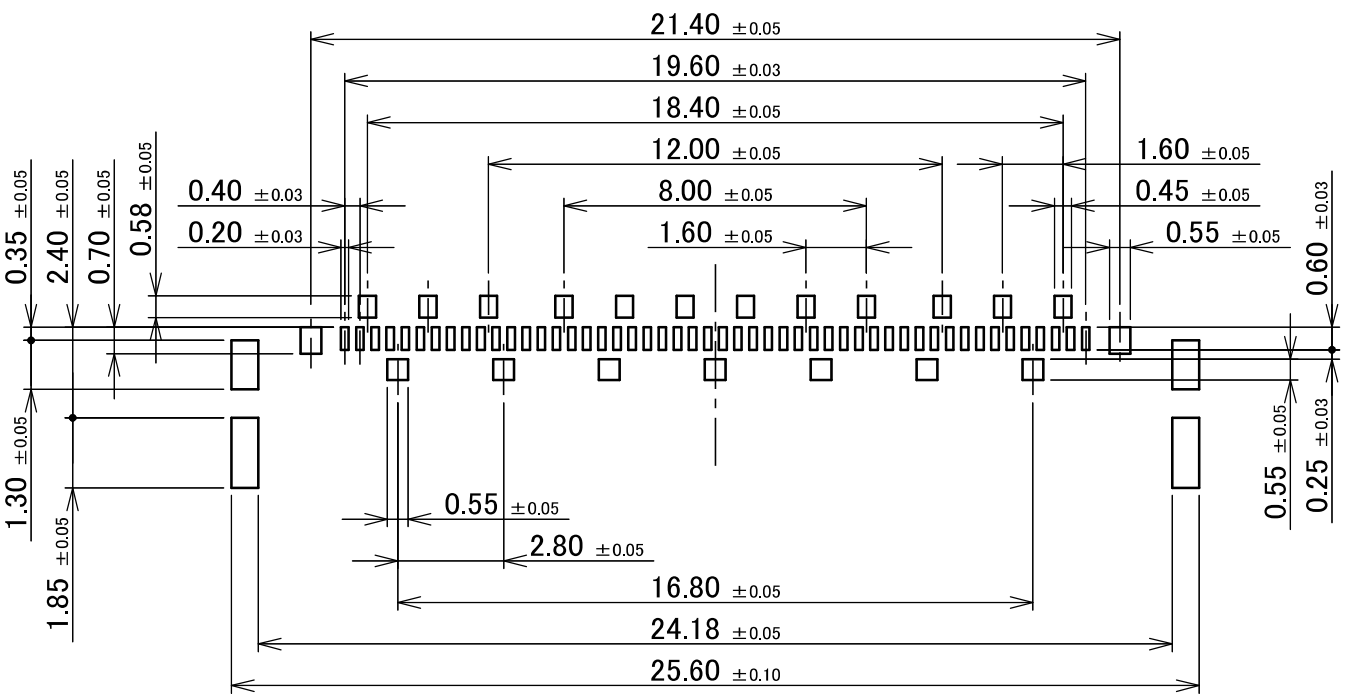

**50P RECOMMENDED METAL MASK LAYOUT  
METAL MASK THICKNESS : t=0.12mm**

NOTES.  
3. DO NOT MOUNT ANOTHER COMPONENT IN THIS AREA.  
4. SOLDER RESIST MUST BE APPLIED TO THIS AREA.

ANGLE	±2°	6 OVER 30 MAX.	±0.3	PROJECTION	SERIES No.	CUSTOMER COPY	
	6 MAX.	30 OVER 120 MAX.	±0.5		R1		
GENERAL TOLERANCE.				TITLE	SCALE	<b>I-PEX</b>	
DWG.	DATE			CABLIN <sup>®</sup> -CA II RECEPTACLE ASSEMBLY	5:1		
CHK.					UNIT		
APP.					mm		
				DWG. No.	SIZE	SHEET	REV.
				20682	A3	6/8	16

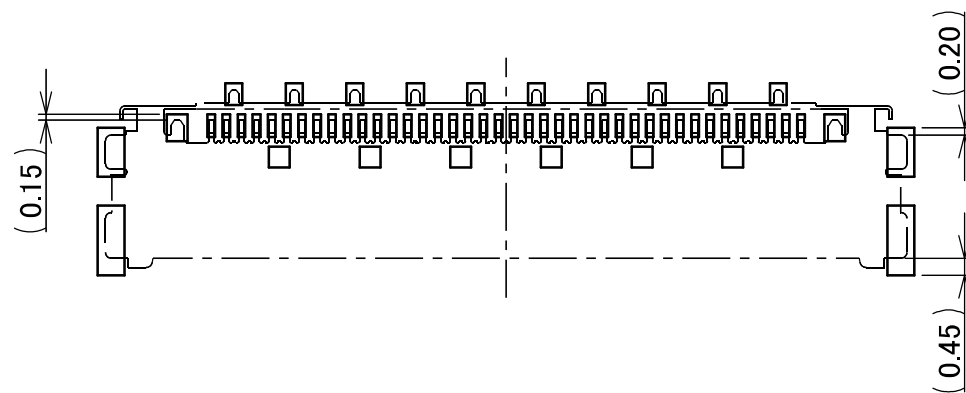

CONNECTOR ON RECOMMENDED FOOTPRINT PATTERN

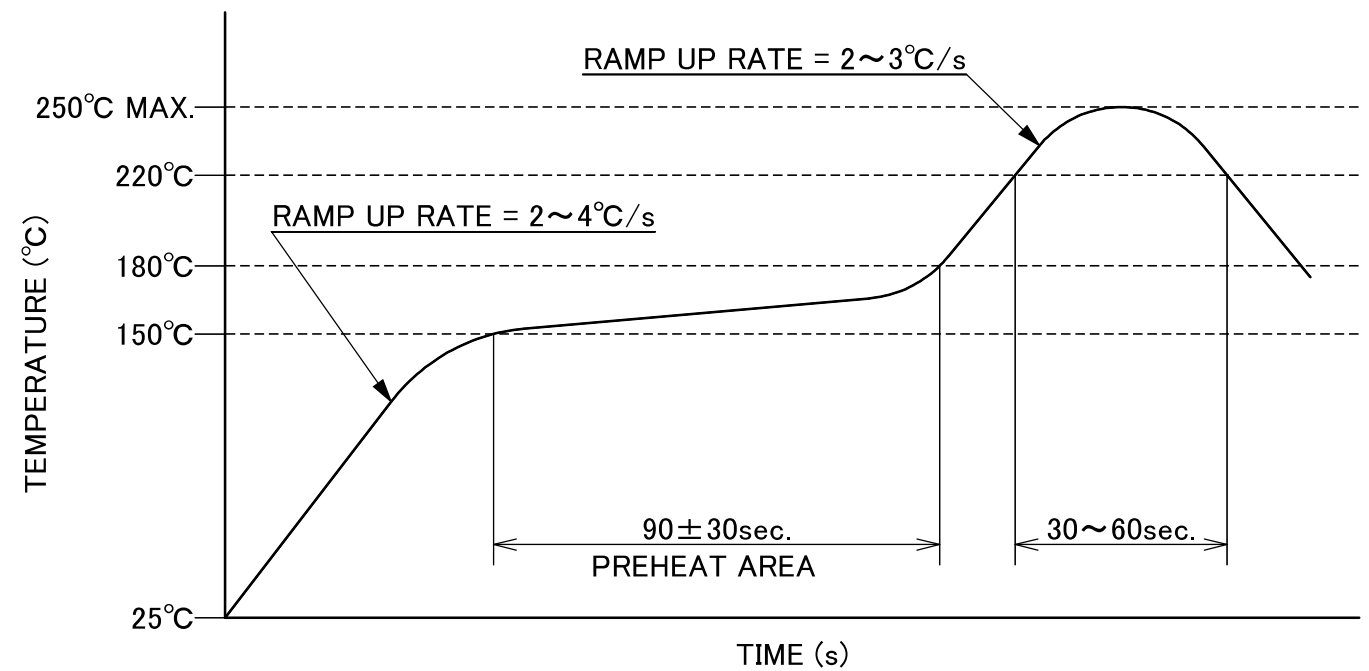

REFLOW TEMPERATURE PROFILE  
SENJU METAL INDUSTRY CO., LTD. : M705-SHF(Sn96.5 Ag3.0 Cu0.5)

ANGLE	±2°	6 OVER 30 MAX.	±0.3	PROJECTION 	SERIES No. R1	CUSTOMER COPY		
6 MAX.	±0.2	30 OVER 120 MAX.	±0.5					
GENERAL TOLERANCE.				TITLE CABLIN <sup>®</sup> -CA II RECEPTACLE ASSEMBLY	SCALE 5:1 UNIT mm			
DWG.	DATE							
CHK.								
APP.								
				DWG. No.	20682	SIZE	SHEET	REV.
						A3	7/8	16

PART NO.	G	M	N	P	Q	R	S	T	QTY. PER EMBOSS REEL (PIECES / REEL)	QTY. PER PACKING CARTON (REELS / CARTON)
20682-020E-02	24.00	7.60	9.80	12.00	13.60	11.50	-	24.00	5500 / REEL	5 / CARTON = 27500
20682-030E-02	32.00	14.40	13.80	16.00	17.60	14.20	28.40	32.00		4 / CARTON = 22000
20682-040E-02	32.00	18.40	17.80	20.00	21.60	14.20	28.40	32.00		3 / CARTON = 16500
20682-050E-02	44.00	22.40	21.80	24.00	25.60	20.20	40.40	44.00		

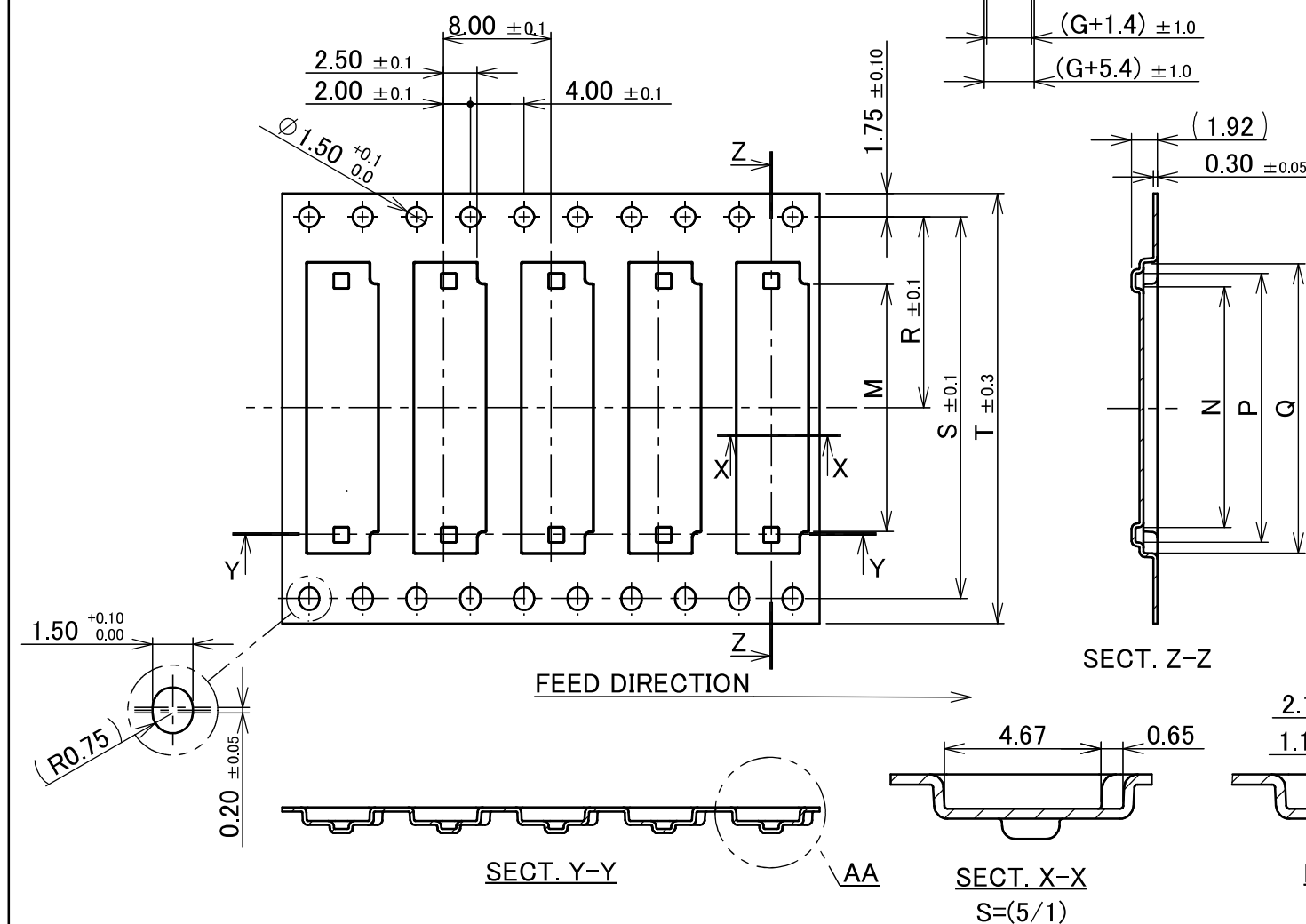
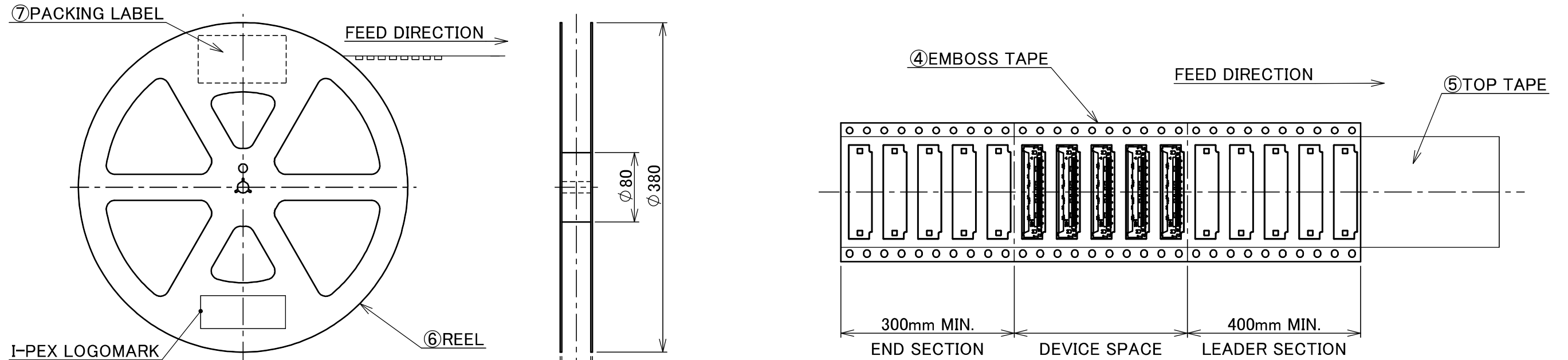

NOTES.

- TAPING SPECIFICATION FOLLOWS JIS C 0806 (IEC 60286-3).
- MAKE EMPTY SECTION OF LEADER AND END ON EACH END OF THE TAPE.
- TOP TAPE SHALL NOT STICK OUT FROM EMBOSS TAPE.
- TOP TAPE SHALL NOT COVER FEED HOLE.

NO.	DISCRIPTION	MATERIAL	FINISH , REMARKS
7	PACKING LABEL	-	-
6	REEL	PS	ANTI-STATIC TYPE BLACK
5	TOP TAPE	PET t=0.062 TRANSPARENCY	ANTI-STATIC TYPE
4	EMBOSS TAPE	PS t=0.3 TRANSPARENCY	ANTI-STATIC TYPE

ANGLE	±2°	6 OVER 30 MAX.	±0.3	PROJECTION	SERIES No.	CUSTOMER COPY		
6 MAX.	±0.2	30 OVER 120 MAX.	±0.5		R1	SCALE		
GENERAL TOLERANCE.						TITLE	5:1	<b>I-PEX</b>
DWG.	DATE		CABLIN® -CA II RECEPTACLE ASSEMBLY			UNIT	mm	
CHK.	DWG. No. 20682					SIZE	SHEET	REV.
APP.						A3	8/8	16