

Recommended P/N 20856-0**T-01

PART No.	A	B	C
20856-030T-01	17.40	14.66	18.95
20856-040T-01	21.40	18.66	22.95
20856-050T-01	25.40	22.66	26.95



Halogen Free



RoHS Compliant

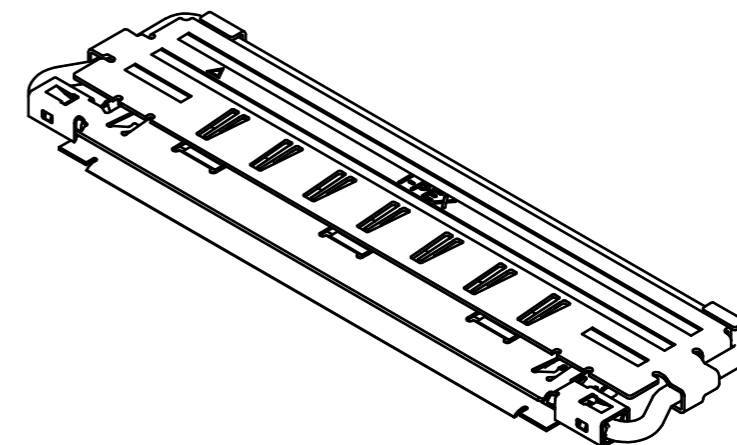
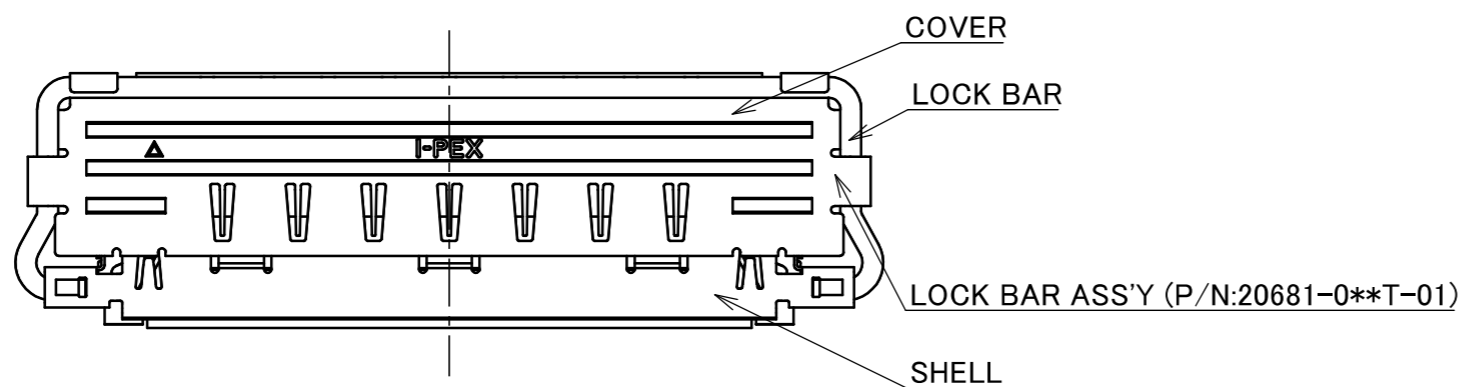
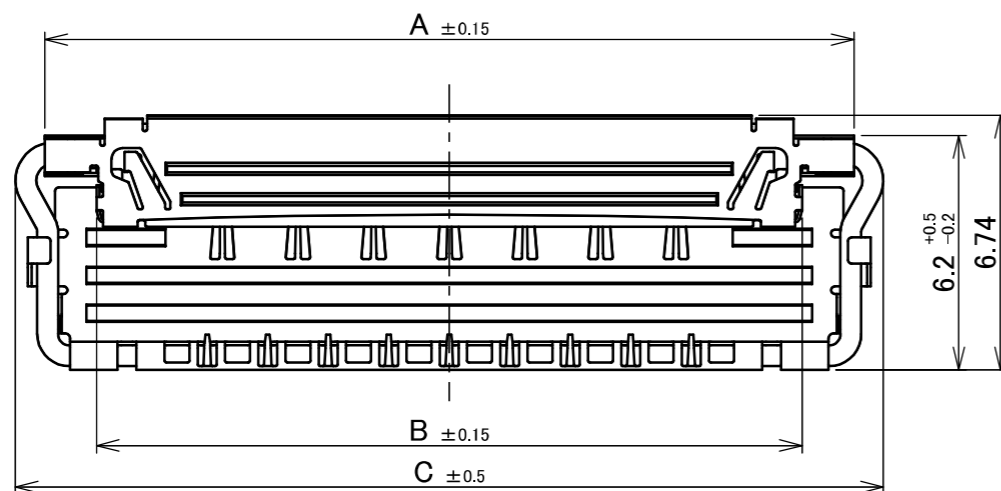

3	COVER	PHOSPHOR BRONZE	Ni PLATING
2	LOCK BAR	STAINLESS STEEL	-
1	SHELL	PHOSPHOR BRONZE	PARTIAL Au 0.003 μm MIN. OVER Ni 1.00 μm MIN.
NO.	DISCRIPTION	MATERIAL	FINISH , REMARKS

13	Z250412	T.O	2025/03/12	T.M	ANGLE	±2°	6 OVER 30 MAX.	±0.3	PROJECTION ⊕	SERIES No. R3	CUSTOMER COPY	
12	Z230464	T.O	2023/04/21	H.I	6 MAX.	±0.2	30 OVER 120 MAX.	±0.5				
11	Z230350	T.O	2023/03/27	H.I	GENERAL TOLERANCE.				TITLE CABLINER® -CA IIF SHELL ASS'Y	SCALE 5:1	UNIT mm	I-PEX
10	Z220750	T.O	2022/07/01	H.I	DWG.	DATE		2017/10/03				
9	Z201289	M.M	2020/12/16	Y.S	Y.Sasa							
8	Z181504	Y.Sasa	2018/09/20	H.I	CHK.	T.Masunaga		DWG. No. 20856	SIZE A3	SHEET 1/6	REV. 13	
REV.	ECN	BY	DATE	APP.	APP.	H.Ikari						
REVISION RECORD												

Recommended P/N 20856-0**T-01

PART No.	A	B	C	D	E
20856-030T-01	17.40	14.66	18.95	12.60	12.40
20856-040T-01	21.40	18.66	22.95	16.60	16.40
20856-050T-01	25.40	22.66	26.95	20.60	20.40

FPC ASS'Y STATE COVER CLOSE



Halogen Free



RoHS Compliant

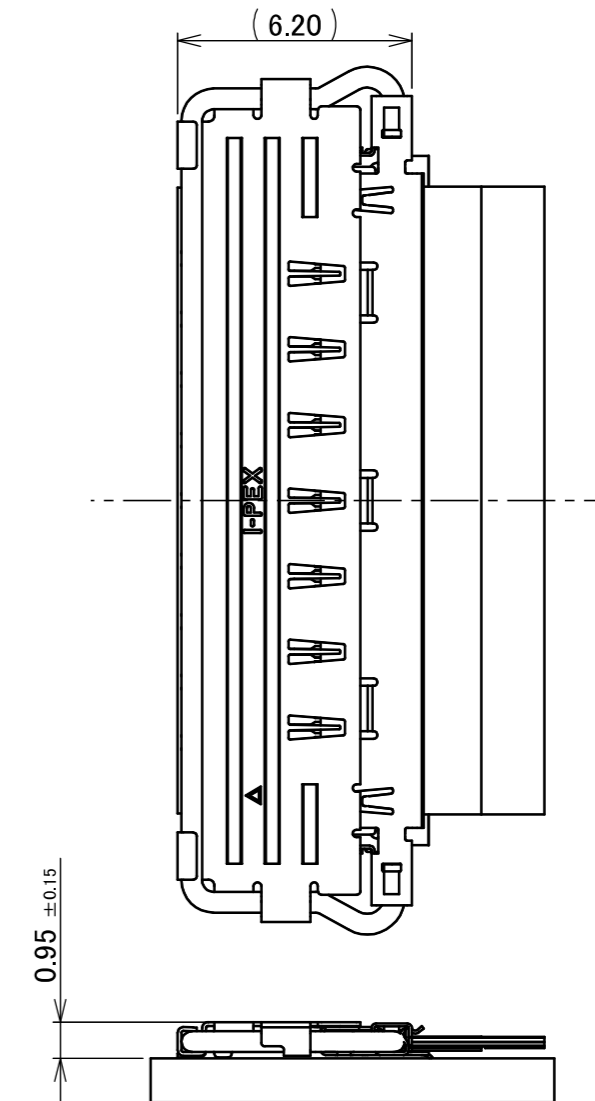
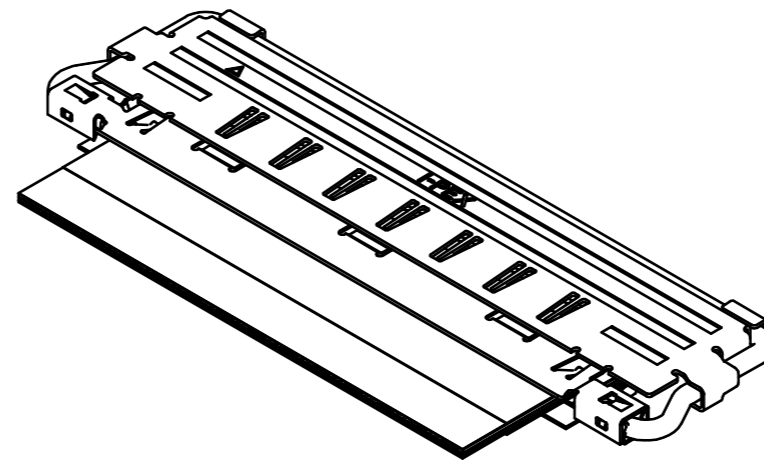
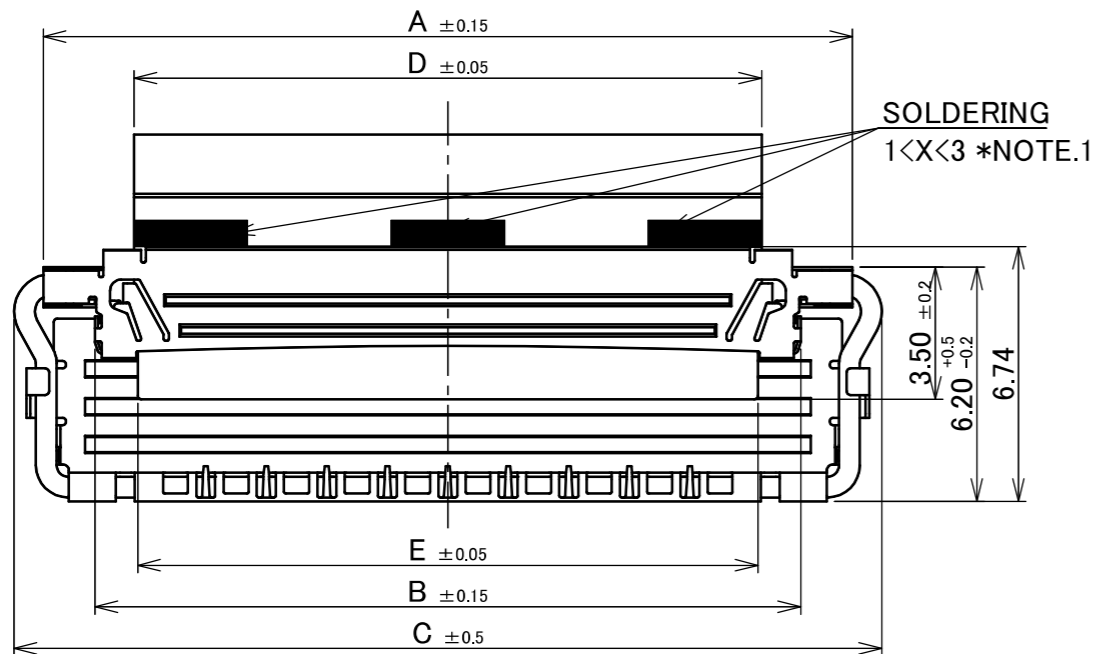

MATING CONDITION

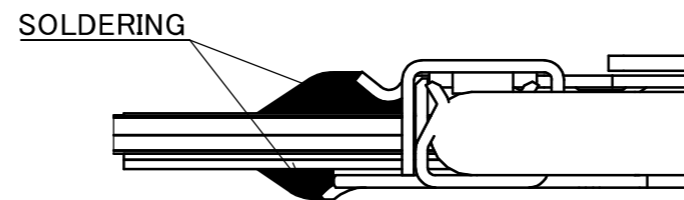
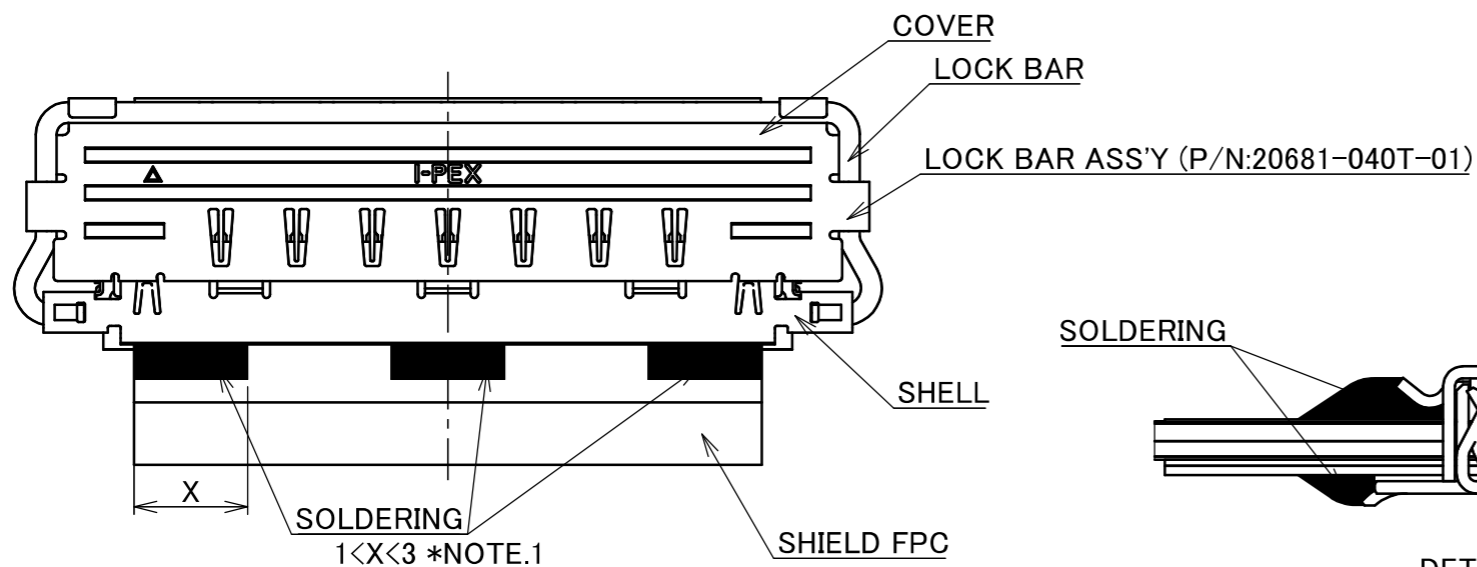

DETAIL Z
(S=20/1)

NOTES.

- Soldering Area X is recommended dimension. It does not matter if it might be exceed the recommended dimension.

ANGLE	±2°	6 OVER 30 MAX.	±0.3	PROJECTION ⊕	SERIES No. R3	CUSTOMER COPY						
	6 MAX.	±0.2	30 OVER 120 MAX.						±0.5			
GENERAL TOLERANCE.				TITLE		SCALE	I-PEX					
DWG.	DATE			CABLIN® -CA IIF SHELL ASS'Y		5:1						
CHK.						UNIT						
APP.				DWG. No. 20856		mm				SIZE	SHEET	REV.
						A3	2/6	13				

Recommended P/N 20856-0**T-01

PART No.	B	E	F
20856-030T-01	14.66	12.40	11.60
20856-040T-01	18.66	16.40	15.60
20856-050T-01	22.66	20.40	19.60



Halogen Free



RoHS Compliant

FPC ASS'Y STATE COVER OPEN

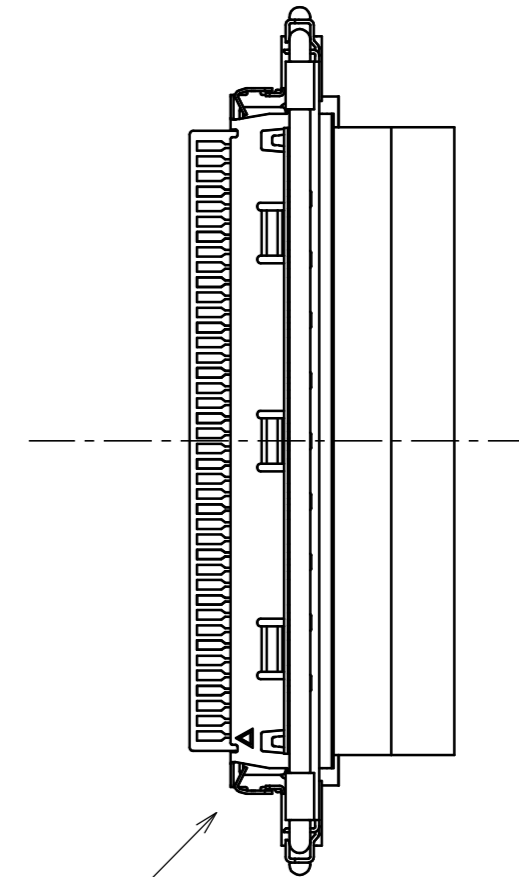
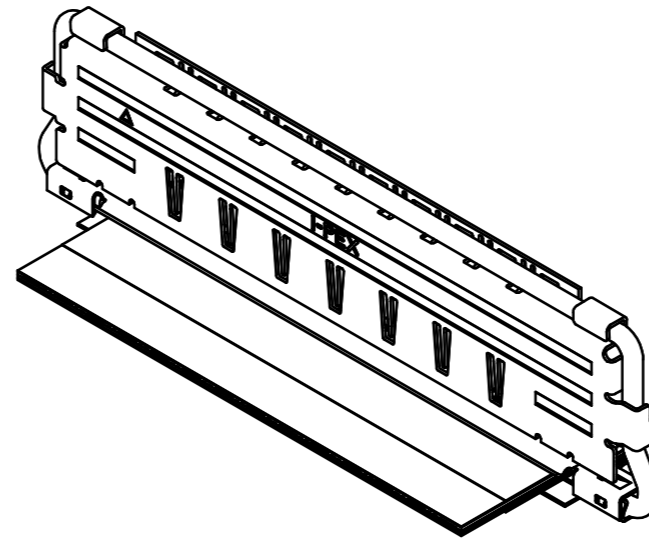
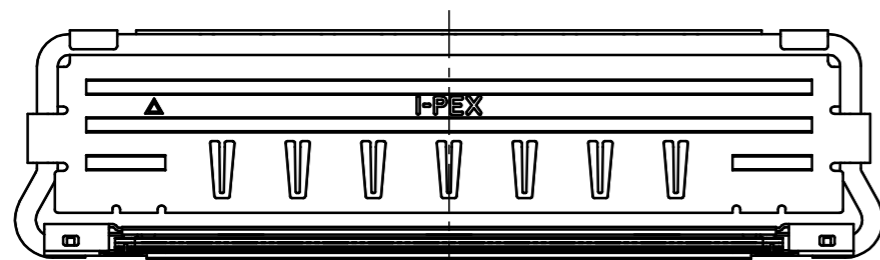
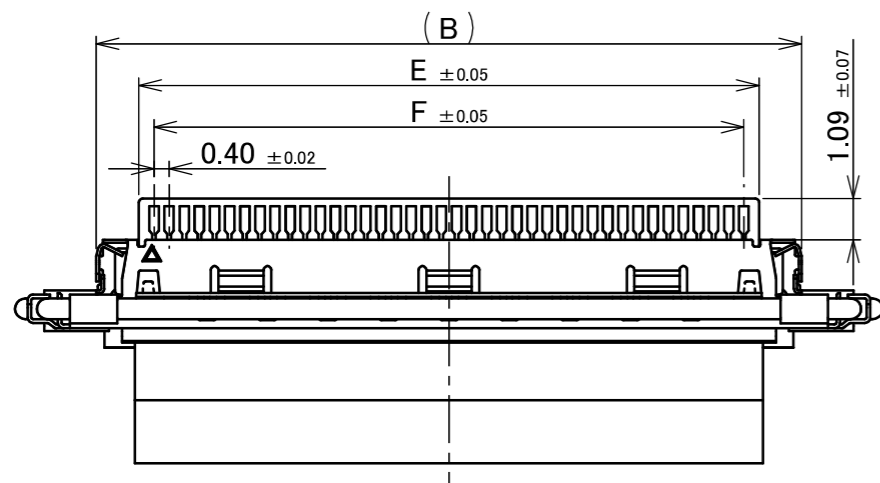
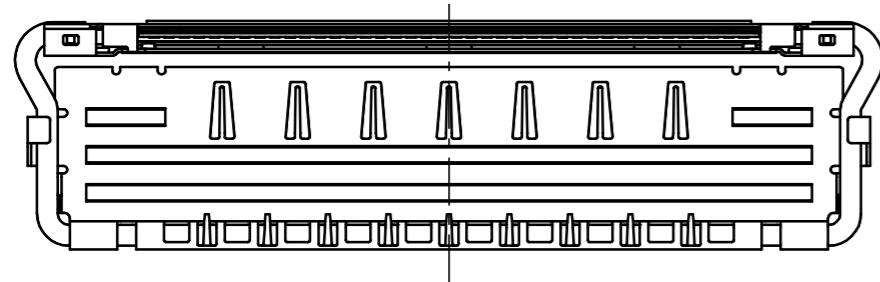
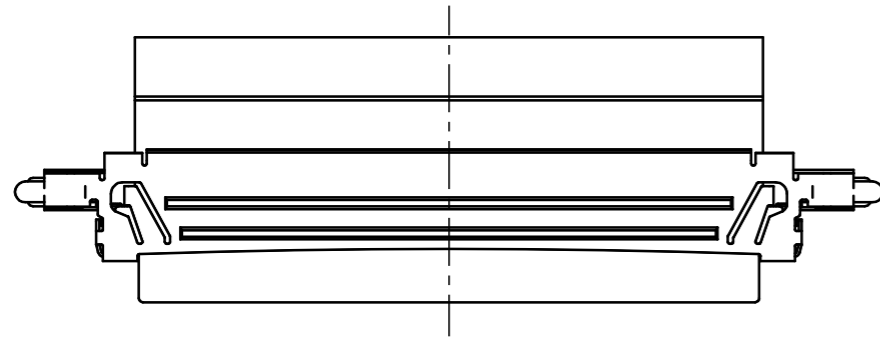

RECEPTACLE ASS'Y(P/N:20682-0**E-0#)

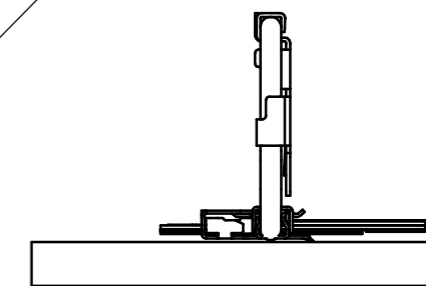

MATING CONDITION

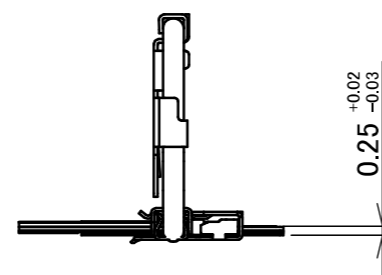

ANGLE	±2°	6 OVER 30 MAX.	±0.3	PROJECTION ⊕	SERIES No. R3	CUSTOMER COPY			
6 MAX.	±0.2	30 OVER 120 MAX.	±0.5						
GENERAL TOLERANCE.				TITLE CABLIN® -CA IIF SHELL ASS'Y		SCALE 5:1	I-PEX		
DWG.	DATE			DWG. No. 20856		UNIT mm			
CHK.									
APP.									

ITEMS	SPECIFICATION
RATING VOLTAGE	100V AC (PER CONTACT PIN)
RATING AMPERAGE (FOR SIGNAL CONTACT)	0.3A AC/DC (PER CONTACT PIN)
OPERATING TEMPERATURE	233~358K(-40°C~+85°C)
OPERATING HUMIDITY	85% MAX.(NON-CONDENSING)
CONTACT RESISTANCE (FOR SIGNAL CONTACT)	INITIAL : 60mohm MAX. / AFTER TEST : \triangle 40mohm MAX.
GROUND SHELL RESISTANCE	INITIAL : 60mohm MAX. / AFTER TEST : \triangle 40mohm MAX.
INSULATION RESISTANCE	INITIAL : 1000Mohm MIN. / AFTER TEST : 500Mohm MIN.
DIELECTRIC WITHSTANDING VOLTAGE	AC250V 1min
DURABILITY	30 CYCLES
MATING FORCE (INITIAL / AFTER TEST)	30P : 13.5N MAX. 40P : 18.0N MAX. 50P : 22.5N MAX.
UNMATING FORCE (INITIAL / AFTER TEST)	30P : 1.44N MIN. 40P : 1.92N MIN. 50P : 2.40N MIN.
PRODUCT SPECIFICATION	PRS-2418
TEST REPORT	TR-17079
PACKING STANDARD	PST-17104
INSTRUCTION MANUAL	HIM-17029
ASSEMBLY MANUAL	ASM-17006
APPEARANCE CRITERIA No.	QLS-A***

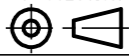
ANGLE	$\pm 2^\circ$	6 OVER 30 MAX.	± 0.3	PROJECTION 	SERIES No. R3	CUSTOMER COPY		
6 MAX.	± 0.2	30 OVER 120 MAX.	± 0.5					
GENERAL TOLERANCE.				TITLE CABLIN [®] -CA IIF SHELL ASS'Y	SCALE -	I-PEX		
DWG.	DATE							
CHK.								
APP.								
				DWG. No.	20856	SIZE	SHEET	REV.
						A3	4/6	13

PART No.	D	E	F	G
20856-030T-01	12.60	12.40	11.60	13.66
20856-040T-01	16.60	16.40	15.60	17.66
20856-050T-01	20.60	20.40	19.60	21.66

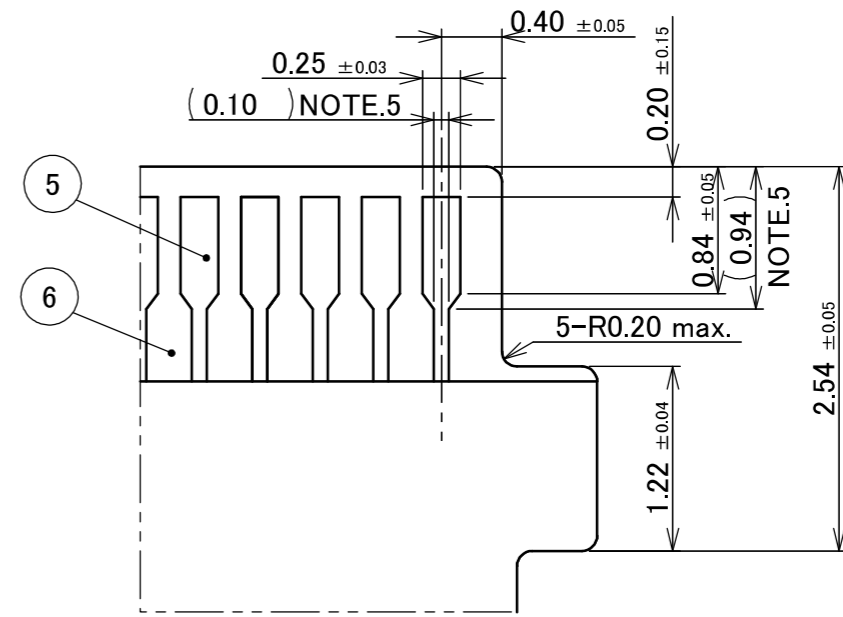
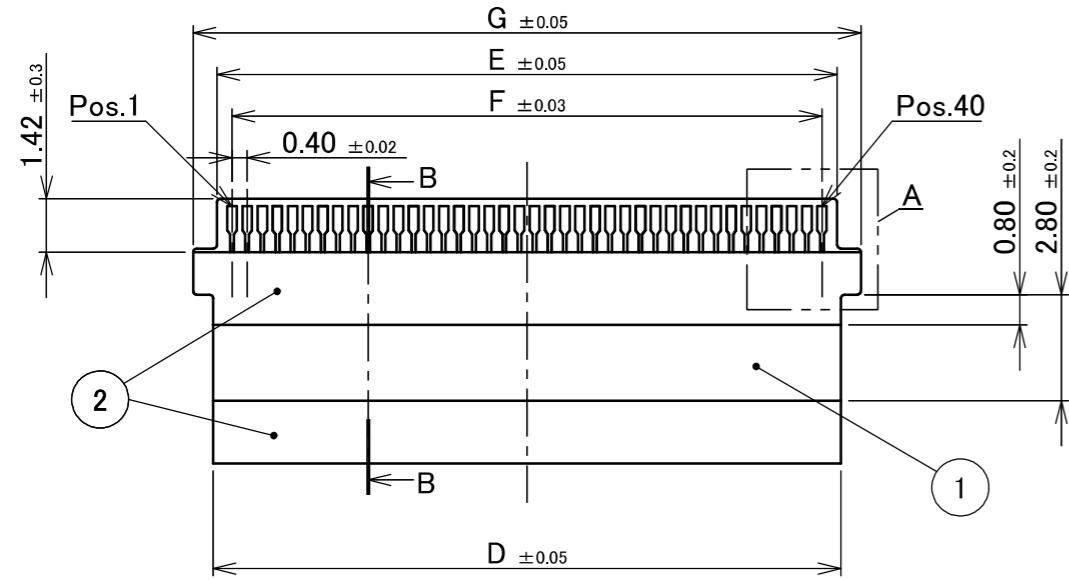

DETAIL A
(S=20 : 1)

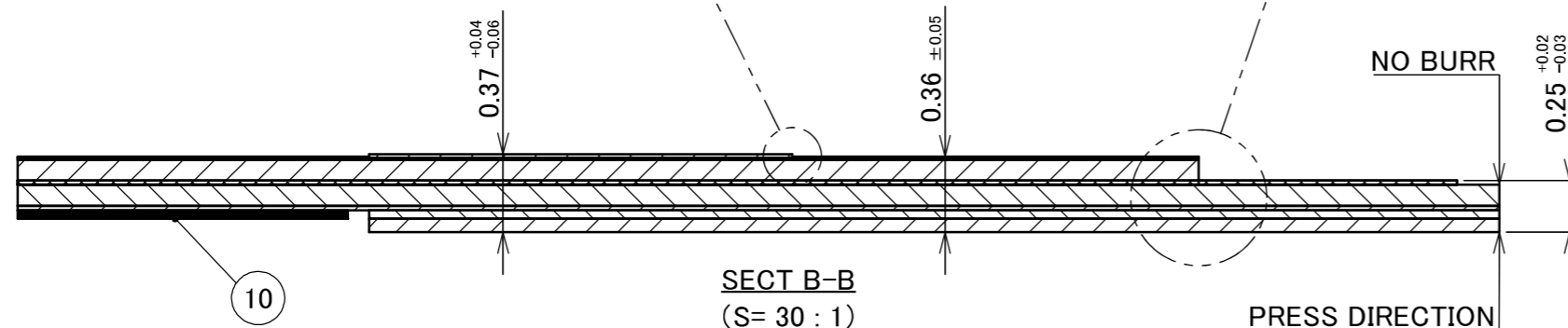
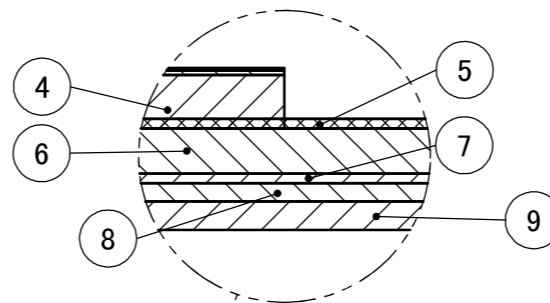
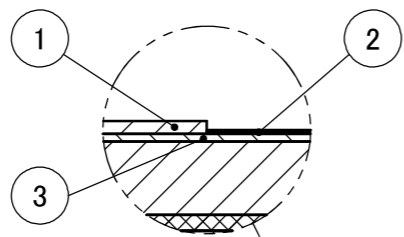
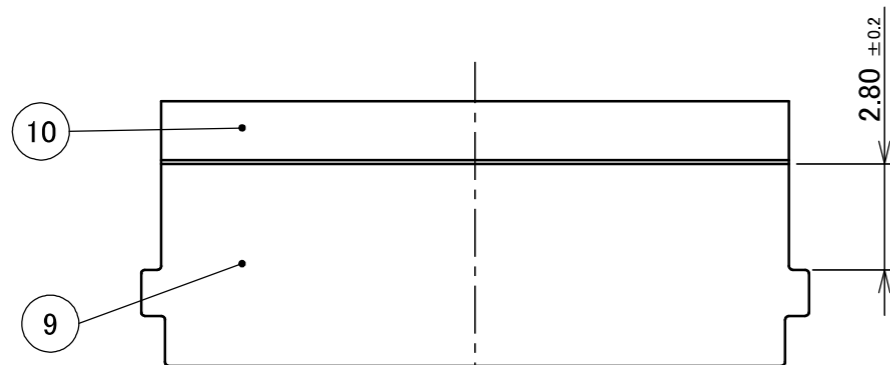

NOTES.

- No.1, 3, 7, 9 : CONDUCTOR (GROUND) ARE CARRYING OUT THE ELECTRICAL CONNECTION.
 - No.5 : SIGNAL Pos. AND No.1, 3, 7, 9 : CONDUCTOR (GROUND) ARE NOT CONTACTING.
 - No.5 : GROUND Pos. AND No.1, 3, 7, 9 : CONDUCTOR (GROUND) ARE CARRYING OUT THE ELECTRICAL CONNECTION.
 - ADHESIVE SHOULD USE THERMOSETTING.
 - NUMBERS WITHIN PARENTHESES ARE ARBITRARY DIMENSIONS.
- CHANGE DIMENSIONS IN ACCORDANCE WITH CHARACTERISTIC IMPEDANCE VALUE.

No.	DESCRIPTION	MATERIAL	PLATING
1	CONDUCTOR(GROUND)	Cu	Ni , Au
2	INSULATOR	-	-
3	CONDUCTOR(GROUND)	Cu	-
4	INSULATOR	-	-
5	CONDUCTOR(SIGNAL, GROUND)	Cu	Ni , Au
6	INSULATOR	-	-
7	CONDUCTOR(GROUND)	Cu	-
8	CONDUCTIVE ADHESIVE	-	-
9	REINFORCING TAPE & CONDUCTOR(GROUND)	SUS	Ni
10	INSULATOR	-	-

ANGLE	±2°	6 OVER 30 MAX.	±0.3	PROJECTION ⊕	SERIES No. R3	CUSTOMER COPY
	6 MAX.	±0.2	30 OVER 120 MAX.			
GENERAL TOLERANCE.				TITLE	SCALE	I-PEX
DWG.	DATE			CABLINER® -CA IIF SHELL ASS'Y	5:1	
CHK.					UNIT	
APP.				DWG. No.	20856	mm
				SIZE	A3	SHEET
						5/6
						REV.
						13

PART NO.	QTY. IN DITCH (PIECES / DITCH)	QTY. IN TRAY (PIECES / TRAY)	QTY. PER SHIPPING CARTON (TRAYS / S CARTON)	QTY. PER PACKING CARTON (S CARTON / P CARTON)
20856-030T-01	1	100	20 / S CARTON =2000	4 / P CARTON = 8000
20856-040T-01	1	100	20 / S CARTON =2000	4 / P CARTON = 8000
20856-050T-01	1	100	20 / S CARTON =2000	4 / P CARTON = 8000

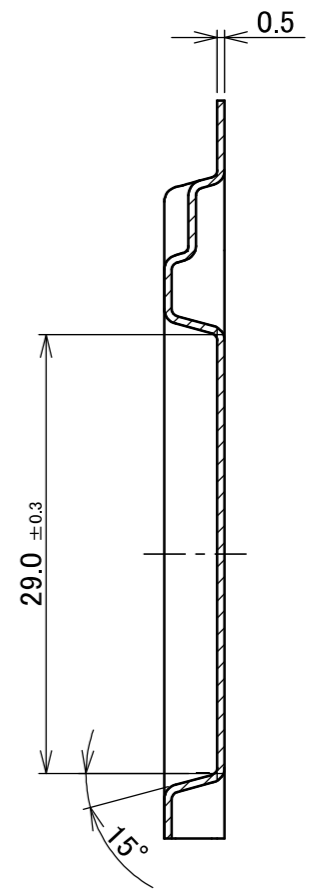
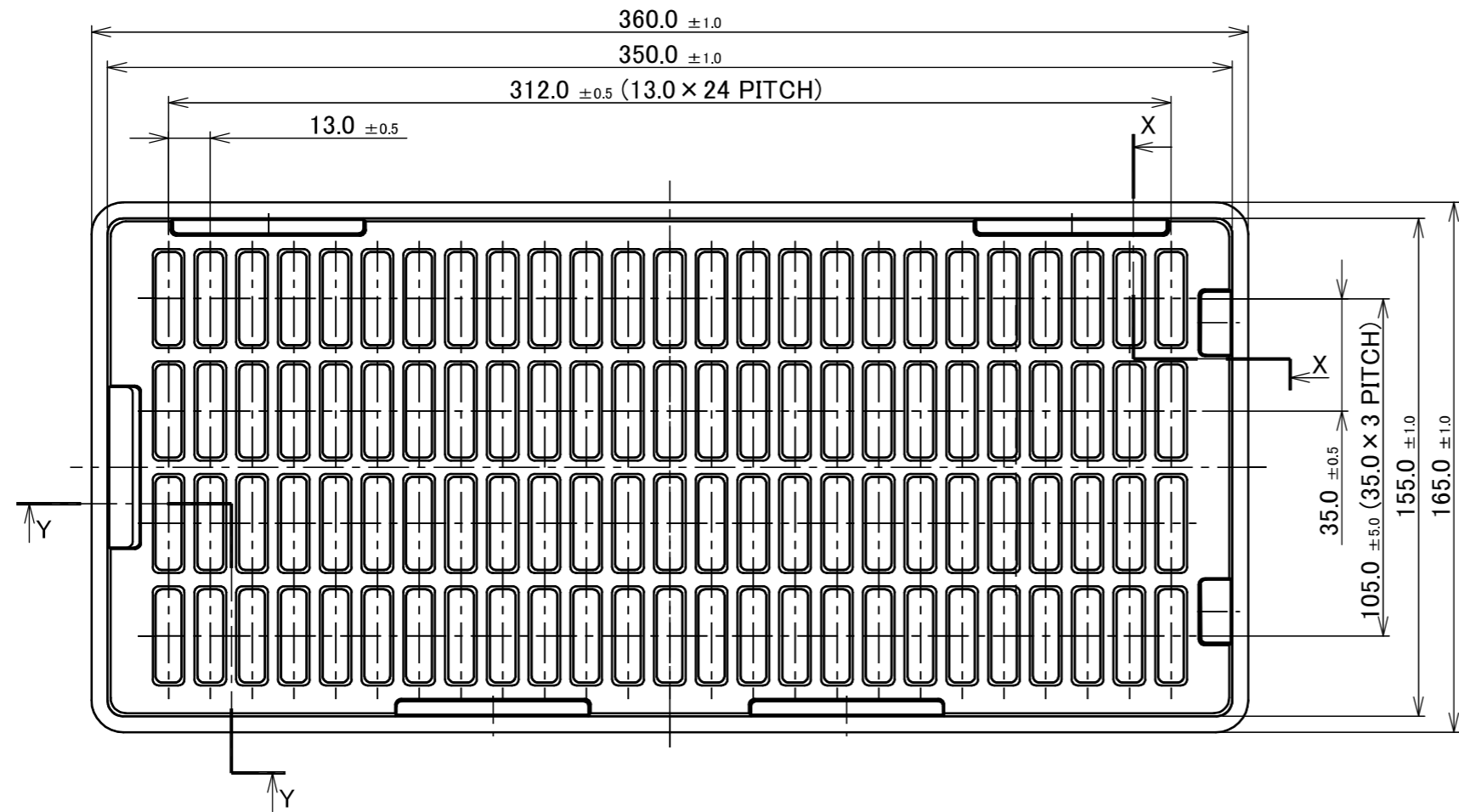

SECT.X-X
(S=2/1)

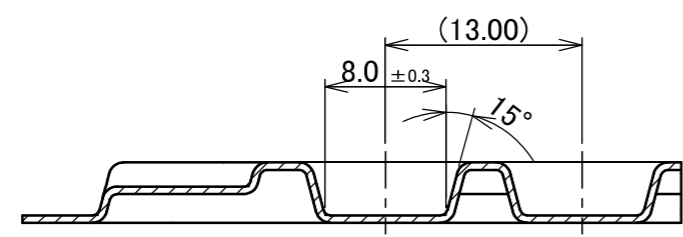
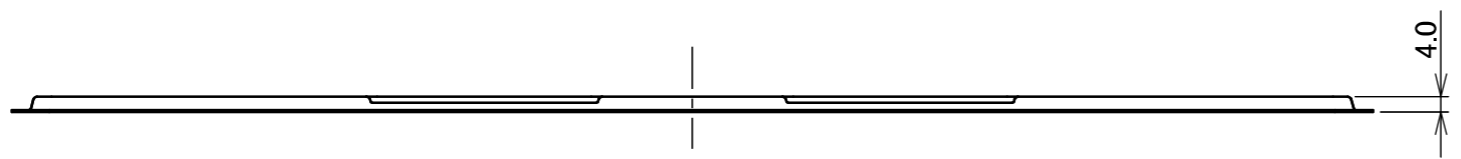

SECT.Y-Y
(S=2/1)

1	TRAY	PP	ANTI-STATIC TYPE
NO.	DISCRIPTION	MATERIAL	FINISH , REMARKS

ANGLE	±2°	6 OVER 30 MAX.	±0.3	PROJECTION ⊕	SERIES No. R3	CUSTOMER COPY						
6 MAX.	±0.2	30 OVER 120 MAX.	±0.5									
GENERAL TOLERANCE.				TITLE		SCALE	I-PEX					
DWG.	DATE			CABLIN® -CA IIF SHELL ASS'Y		1:2						
CHK.						UNIT						
APP.				DWG. No. 20856		mm				SIZE	SHEET	REV.
						A3	6/6	13				