

PART No.
21022-001E

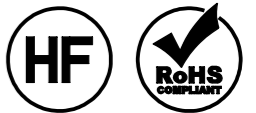

IATF 16949 Cetified [Planned]

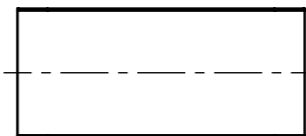
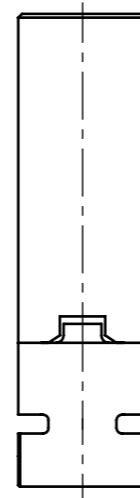
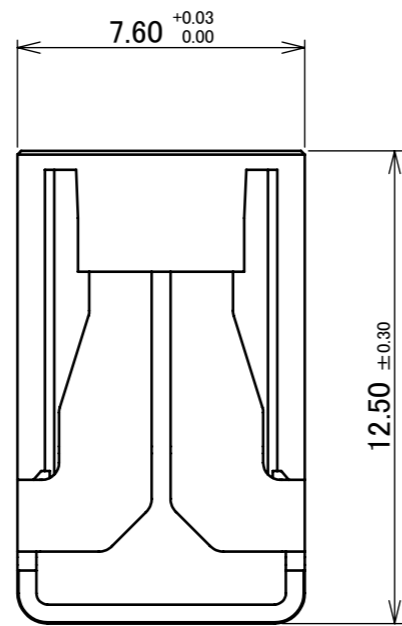
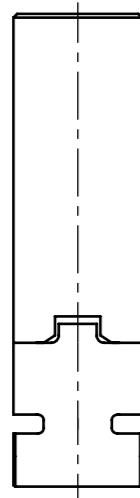
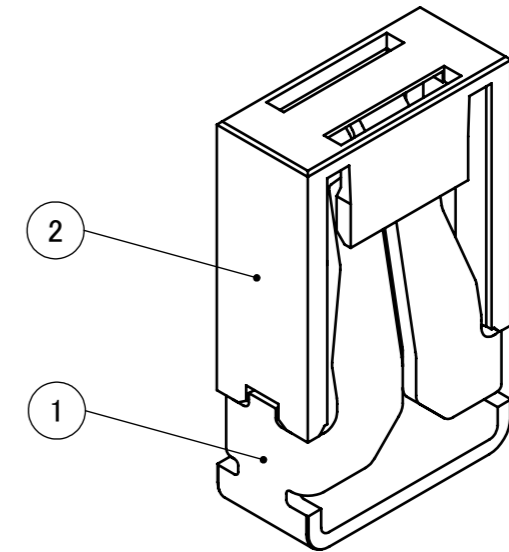
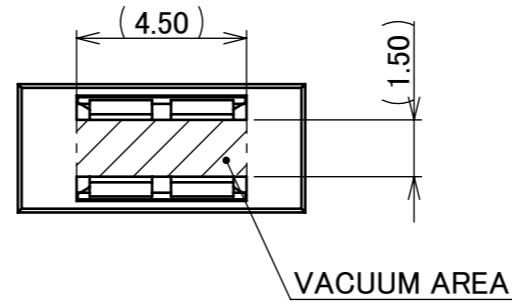
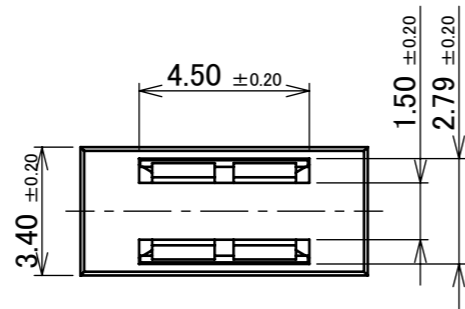

NOTES.
1.RECEPTACLE PART No. :3532-0001-00T

2	CAP	PPA	-
1	RECEPTACLE	COPPER ALLOY	Sn PLATING
NO.	DESCRIPTION	MATERIAL	FINISH,REMARKS

					ANGLE	±2°	6 OVER 30 MAX.	±0.3	PROJECTION	SERIES No.	CUSTOMER COPY				
						6 MAX.	±0.2	30 OVER 120 MAX.	±0.5		R1				
					GENERAL TOLERANCE.				TITLE	SCALE					
					DWG.	F.Jin		DATE	2024/09/04		AP-10		5:1	I-PEX	
					CHK.	S.Kamada				RECEPTACLE WITH CAP		UNIT			
					REV.	ECN	BY	DATE	APP.	DWG. No.		A3	SIZE	SHEET	REV.
REVISION RECORD							Y.Hashimoto		21022		A3	1/4	1		

ITEMS	SPECIFICATION
APPLICABLE CONNECTOR PART No.	3531-0001-00T 3539-0001-45* 21037-001E
RATING AMPERAGE	16A DC
TEMPERATURE RISE	△15.0°C MAX.
COMPONENT TEMPERATURE(ENERGIZATION)	233~378K(-40°C~+105°C)
OPERATING HUMIDITY	85% MAX.(NON-CONDENSING)
CONTACT RESISTANCE	INITIAL : 1.0 mohm MAX. / AFTER TEST : 1.0 mohm MAX.
DURABILITY	3 CYCLES
MATING FORCE/UNMATING FORCE	15.0 N MAX./15.0 N MAX.
COPLANARITY	0.10mm MAX.
PRODUCT SPECIFICATION	PRS-2616
TEST REPORT	TR-19063
PACKING STANDARD	PST-17121
INSTRUCTION MANUAL	HIM-22021
APPEARANCE CRITERIA No.	QLS-A***

※SPECIFICATIONS INDICATED - ARE SAME AS AP-10 RECEPTACLE.

ANGLE	±2°	6 OVER 30 MAX.	±0.3	PROJECTION ①	SERIES No. R1	CUSTOMER COPY		
6 MAX.	±0.2	30 OVER 120 MAX.	±0.5					
GENERAL TOLERANCE.				TITLE AP-10 RECEPTACLE WITH CAP	SCALE 5:1 UNIT mm	I-PEX		
DWG.	DATE							
CHK.								
APP.								
				DWG. No.	21022	SIZE A3	SHEET 2/4	REV. 1

PART NO.
21022-001E

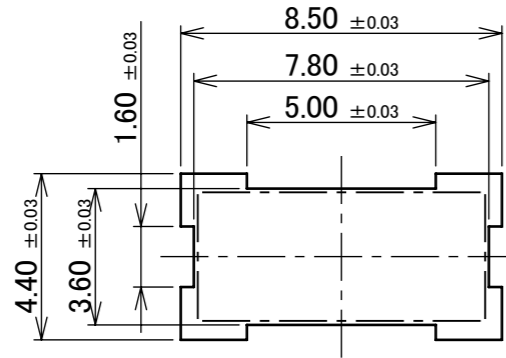

RECOMMENDED FOOTPRINT PATTERN

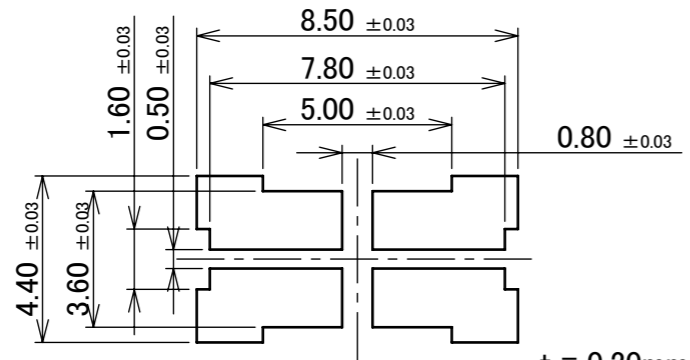

RECOMMENDED METAL MASK

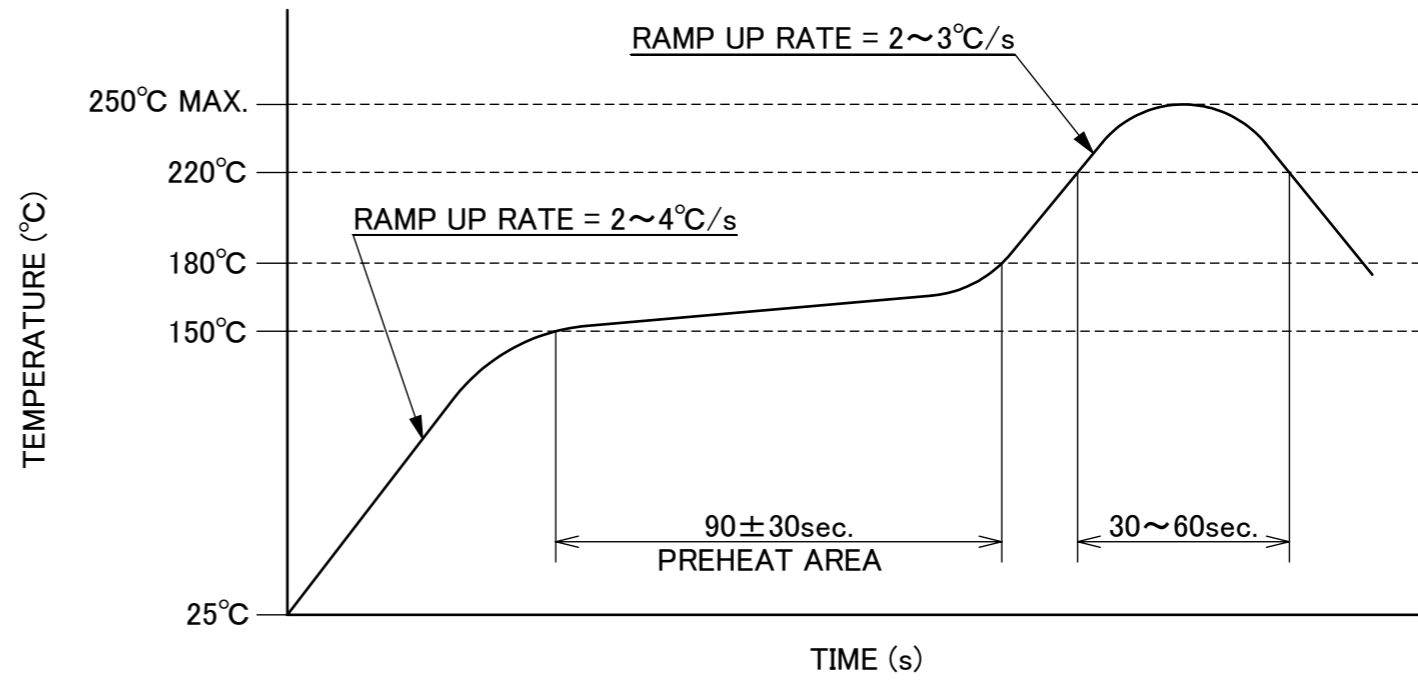

REFLOW TEMPERATURE PROFILE
SENJU METAL INDUSTRY CO., LTD. : M705-SHF(Sn96.5 Ag3.0 Cu0.5)

ANGLE	±2°	6 OVER 30 MAX.	±0.3	PROJECTION ⊕	SERIES No. R1	CUSTOMER COPY		
6 MAX.	±0.2	30 OVER 120 MAX.	±0.5					
GENERAL TOLERANCE.				TITLE AP-10 RECEPTACLE WITH CAP	SCALE 5:1 UNIT mm	I-PEX		
DWG.	DATE							
CHK.								
APP.								
				DWG. No.	21022	SIZE A3	SHEET 3/4	REV. 1

PART NO.	QTY. PER EMBOSS REEL (PIECES / REEL)	QTY. PER PACKING CARTON (REELS / CARTON)
21022-001E	350 PIECES / REEL	5 REELS / CARTON = 1,750 PIECES

IATF 16949 Cetified [Planned]

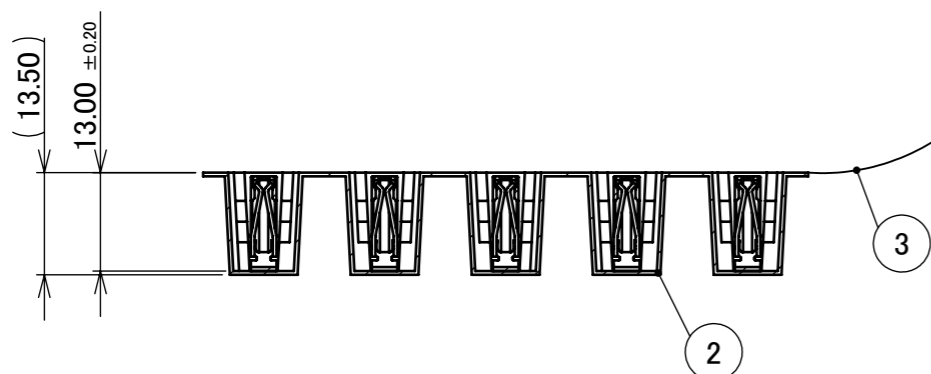
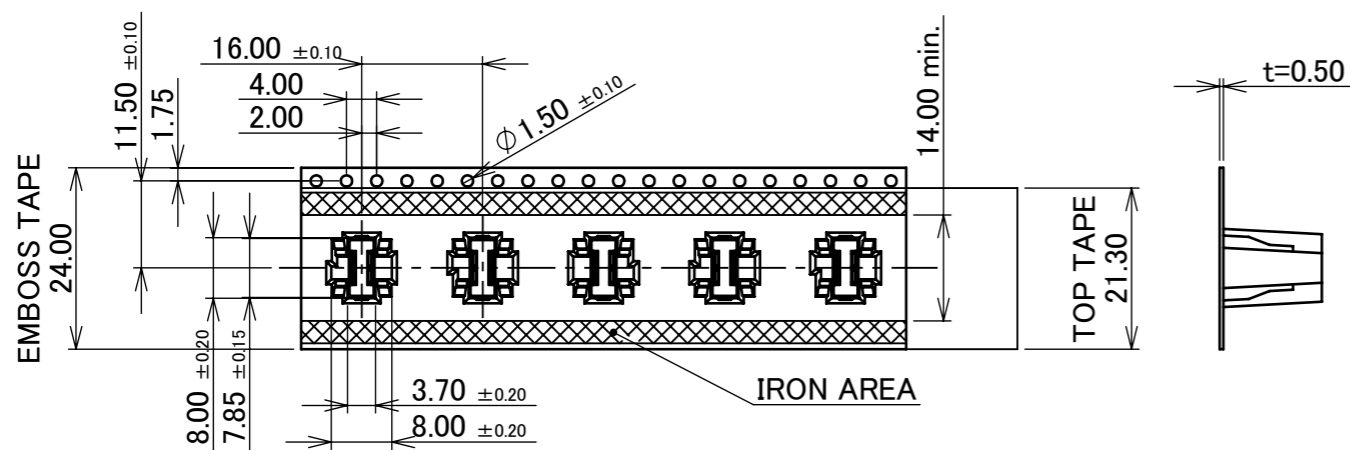
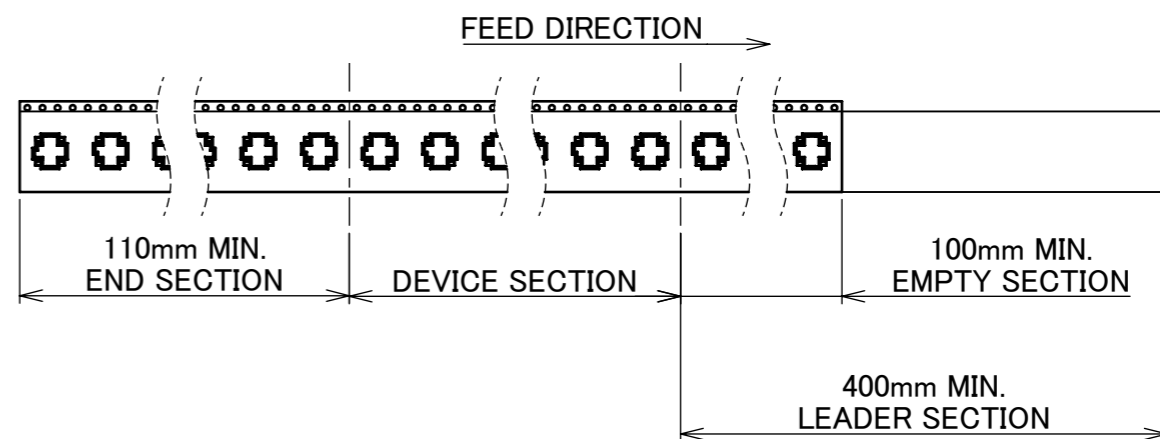
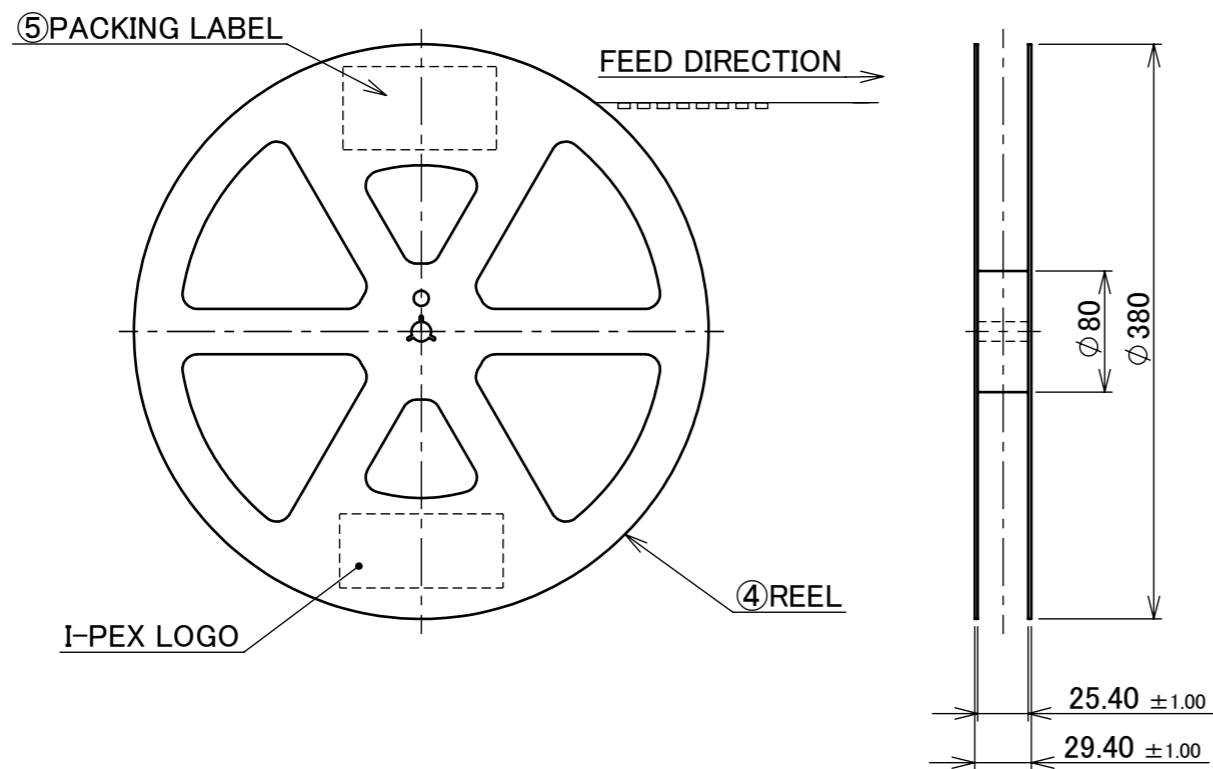

- NOTES.
- TAPING SPECIFICATION FOLLOWS JIS C 0806 (IEC 60286-3).
 - MAKE EMPTY SECTION OF LEADER AND END ON EACH END OF THE TAPE.
 - TOP TAPE SHALL NOT STICK OUT FROM EMBOSS TAPE.
 - TOP TAPE SHALL NOT COVER FEED HOLE.

NO.	DESCRIPTION	MATERIAL	FINISH , REMARKS
5	PACKING LABEL	-	-
4	REEL	PS	BLACK
3	TOP TAPE	PET	ANTI-STATIC TYPE
2	EMBOSS TAPE	PS	ANTI-STATIC TYPE
1	CONNECTOR	COPPER ALLOY	-

ANGLE	±2°	6 OVER 30 MAX.	±0.3	PROJECTION ⊕	SERIES No. R1	CUSTOMER COPY		
6 MAX.	±0.2	30 OVER 120 MAX.	±0.5					
GENERAL TOLERANCE.				TITLE AP-10 RECEPTACLE WITH CAP	SCALE 5:1 UNIT mm	I-PEX		
DWG.	DATE							
CHK.								
APP.								
DWG. No. 21022				SIZE A3	SHEET 4/4	REV. 1		