

PART NO.

3224-0001

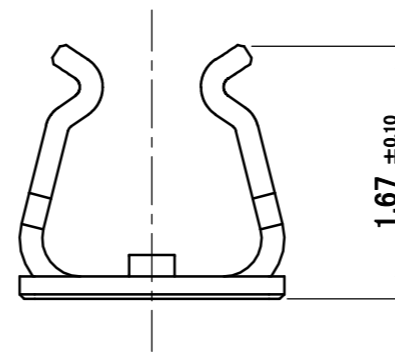
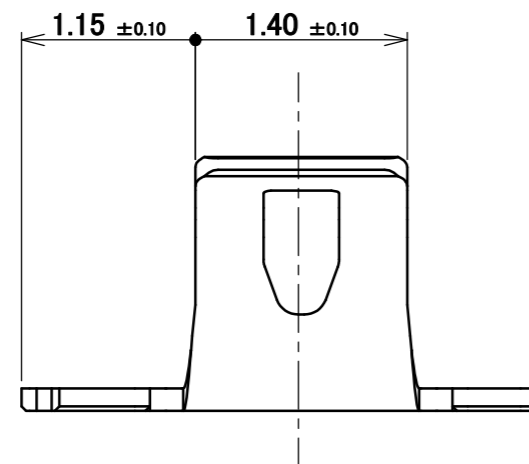
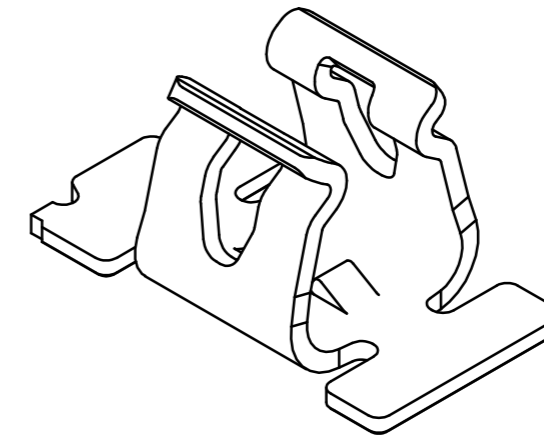
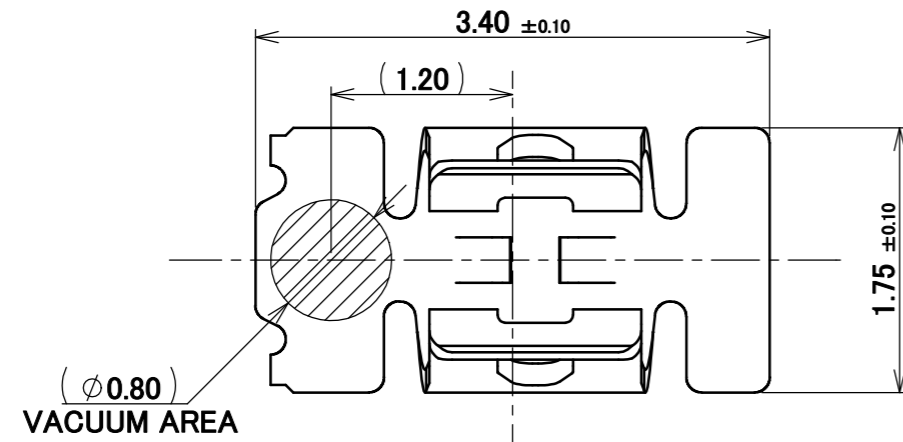
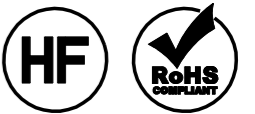

1	MP-A04	PHOSPHOR BRONZE	CONTACT PART Sn 2.00 μm MIN. OVER Ni 1.00 μm MIN. SOLDERING PART Sn 1.00 μm MIN.OVER Ni 0.50 μm MIN.
NO.	DESCRIPTION	MATERIAL	FINISH , REMARKS

					ANGLE	±2°	6 OVER 30 MAX.	±0.3	PROJECTION	SERIES No.	CUSTOMER COPY	
					6 MAX.	±0.2	30 OVER 120 MAX.	±0.5		R0		
3	Z180872	S.K	2018/09/20	Ken	GENERAL TOLERANCE.				MP-A04	SCALE	I-PEX	
2	Z180302	M.N	2018/03/08	Ken	DWG.	S.Taguchi	DATE	2015/11/20		UNIT		
1	Z170683	M.N	2017/06/13	Ken	CHK.	K.Yotsutani	DATE	2015/11/20		mm		
0	Z151320	S.T	2015/11/20		APP.	T.Takano	DATE	2015/11/20		SIZE		
REV.	ECN	BY	DATE	APP.	REVISION RECORD				DWG. No.	A3	SHEET 1/7	REV. 3

PART NO.
3224-0003

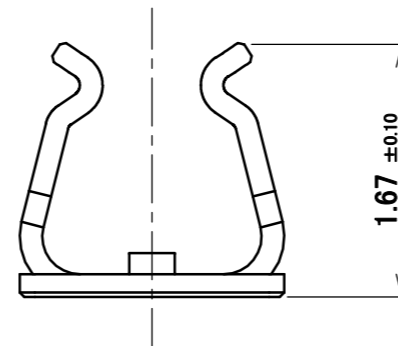
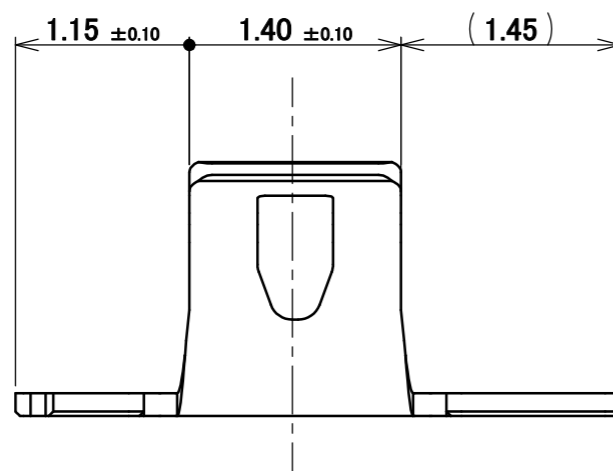
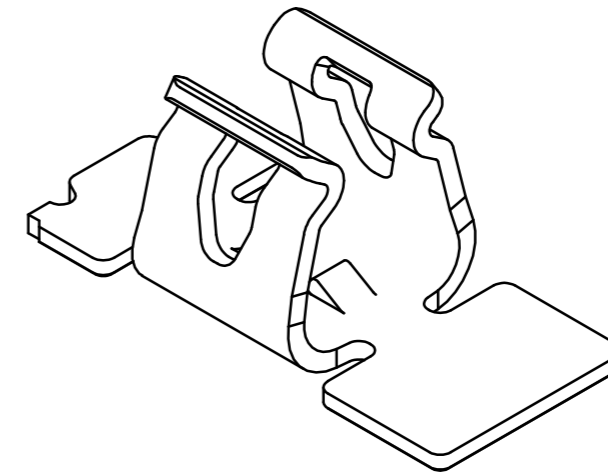
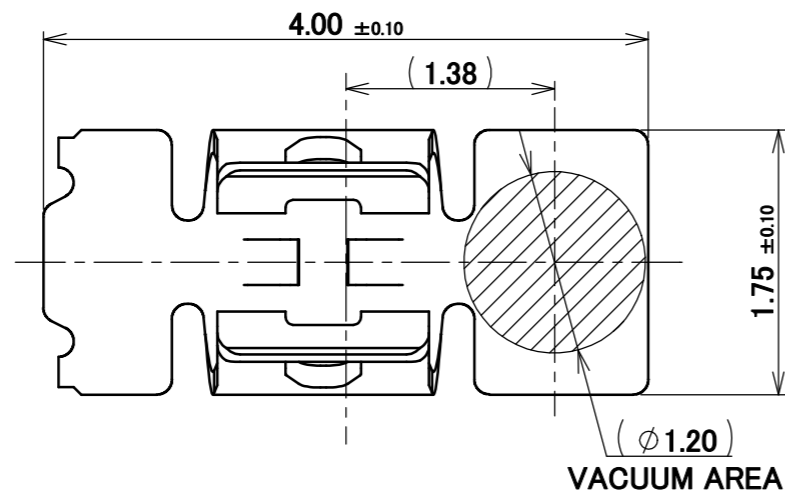
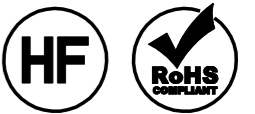

ANGLE	±2°	6 OVER 30 MAX.	±0.3	PROJECTION ⊕	SERIES No. R0	CUSTOMER COPY	
6 MAX.	±0.2	30 OVER 120 MAX.	±0.5				
GENERAL TOLERANCE.				TITLE		SCALE	I-PEX
DWG.	DATE		MP-A04		20:1		
CHK.	DATE				UNIT		
APP.	DATE				mm		
				DWG. No.	3224	SIZE	SHEET 2/7 REV. 3
						A3	

REVISION RECORD

ITEMS	SPECIFICATION
APPLICABLE CONNECTOR PART No.	<ul style="list-style-type: none"> •CABLE CLAMP (3mm) FOR Φ 1.37 COAXIAL CABLE (DAI-ICHI SEIKO P/N: 3223-030*) •CABLE CLAMP (6mm) FOR Φ 1.37 COAXIAL CABLE (DAI-ICHI SEIKO P/N: 3223-060*) •CABLE JACKET (OUTSIDE DIAMETER Φ 1.37\pm0.08) OF Φ 1.37 COAXIAL CABLE
OPERATING TEMPERATURE	233~358K(-40°C~+85°C)
OPERATING HUMIDITY	85% MAX.(NON-CONDENSING)
CONTACT RESISTANCE	INITIAL : 70mohm MAX. / AFTER TEST : 70mohm MAX.
DURABILITY	5 CYCLES
MATING FORCE (INITIAL / AFTER TEST)	INITIAL : 25N MAX. / AFTER TEST : 25N MAX.
UNMATING FORCE (INITIAL / AFTER TEST)	INITIAL : 3N MIN. / AFTER TEST : 2N MIN.
PRODUCT SPECIFICATION	PRS-2235
TEST REPORT	TR-16134
PACKING STANDARD	PST-15066
INSTRUCTION MANUAL	HIM-16012

ANGLE	$\pm 2^\circ$	6 OVER 30 MAX.	± 0.3	PROJECTION 	SERIES No. R0	CUSTOMER COPY
	6 MAX.	± 0.2	30 OVER 120 MAX.			
GENERAL TOLERANCE.				TITLE MP-A04	SCALE -	UNIT mm
DWG.	DATE					
CHK.	DATE					
APP.	DATE					
				DWG. No.	3224	SIZE A3
						SHEET 3/7 REV. 3

① ϕ 1.37 COAXIAL CABLE WITH 3mm CABLE CLAMP (P/N : 3223-0302)

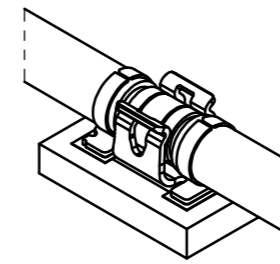
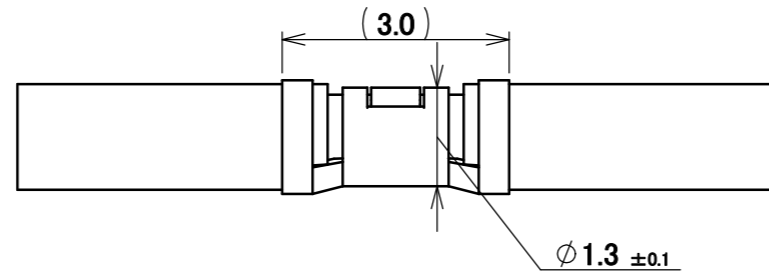

3224-0001

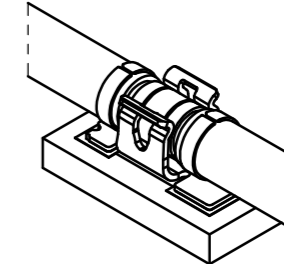

33224-0003

② ϕ 1.37 COAXIAL CABLE WITH 6mm CABLE CLAMP (P/N : 3223-0602)

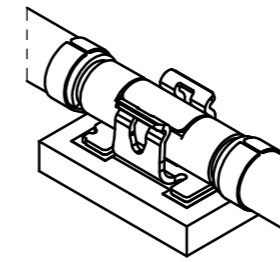
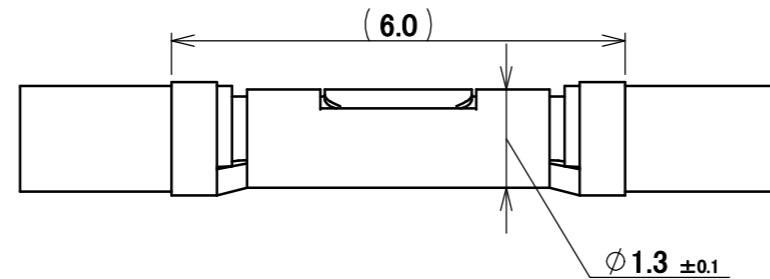

3224-0001

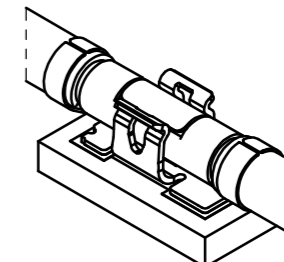

33224-0003

③ ϕ 1.37 COAXIAL CABLE

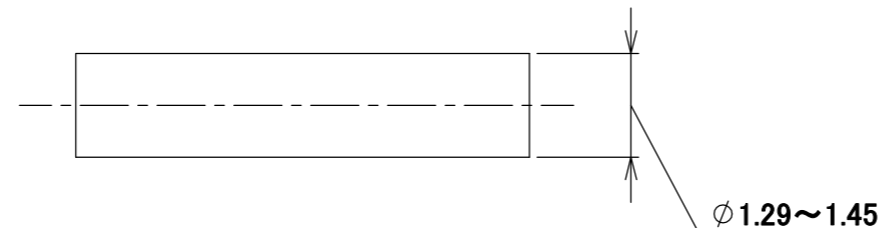

APPLICABLE CABLE

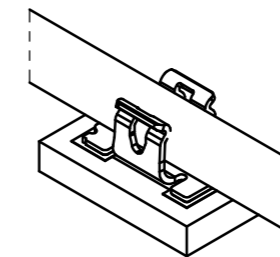

3224-0001

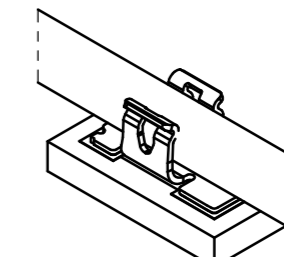

33224-0003

MATING CONDITION
(S = 6/1)

NOTE.
1. ONLY A SIMILAR CABLE IS REPLACEABLE.

ANGLE	$\pm 2^\circ$	6 OVER 30 MAX.	± 0.3	PROJECTION 	SERIES No. R0	CUSTOMER COPY	
6 MAX.	± 0.2	30 OVER 120 MAX.	± 0.5				
GENERAL TOLERANCE.				TITLE MP-A04	DWG. No. 3224	SCALE	I-PEX
DWG.	DATE	SIZE	SHEET 4/7 REV. 3				
CHK.	DATE	mm					
APP.	DATE	A3					

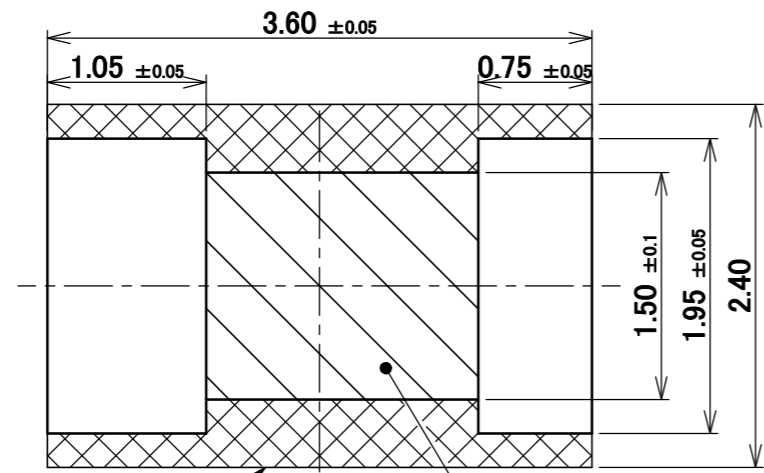

SEE NOTE. 3
 SEE NOTE. 2
RECOMMENDED FOOTPRINT PATTERN
3224-0001

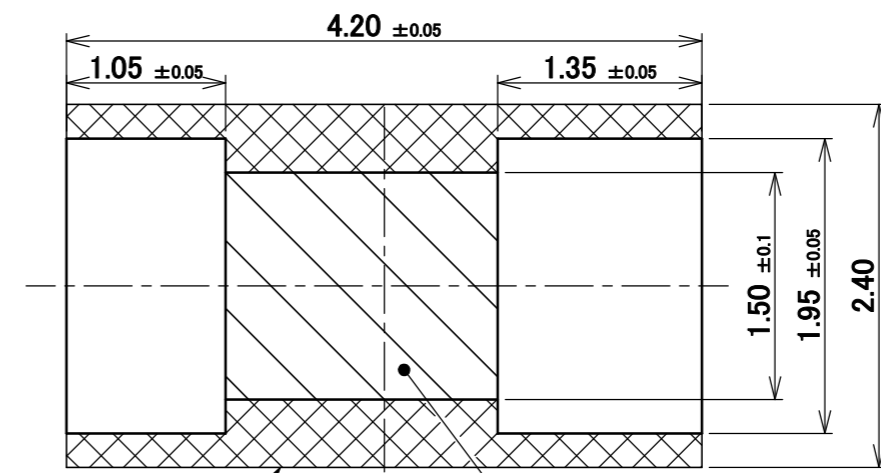

SEE NOTE. 3
 SEE NOTE. 2
RECOMMENDED FOOTPRINT PATTERN
3224-0003

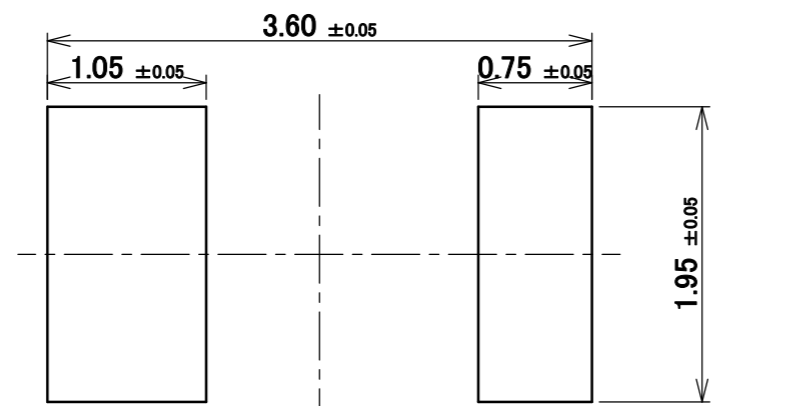

METAL MASK
3224-0001 **THICKNESS: 0.10mm**

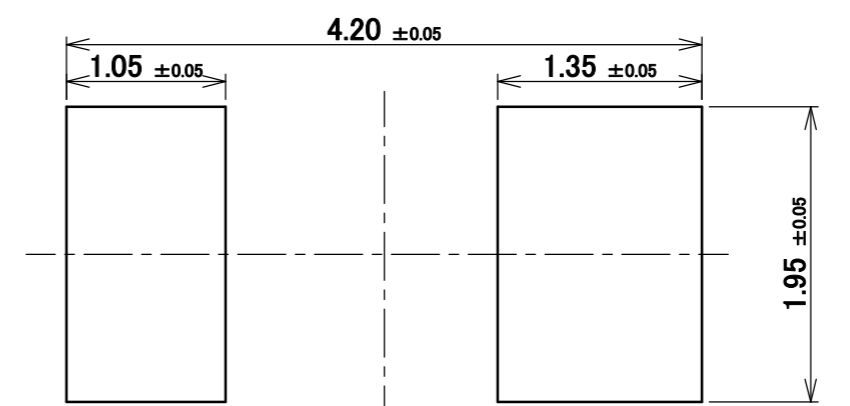

METAL MASK
3224-0003 **THICKNESS: 0.10mm**

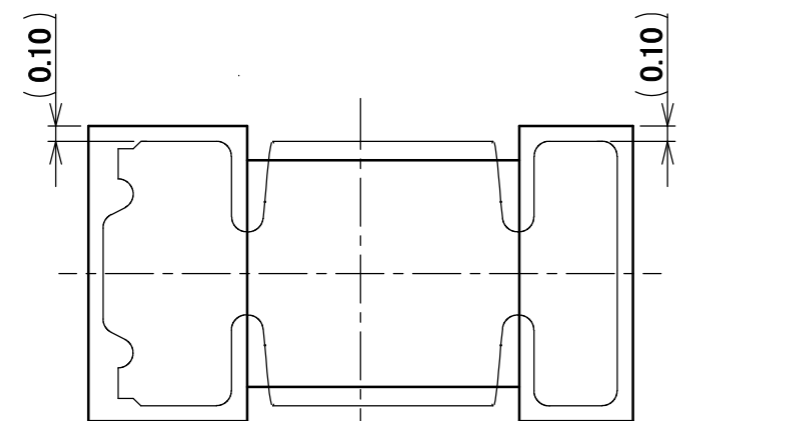

CONNECTOR ON RECOMMENDED FOOTPRINT PATTERN
3224-0001

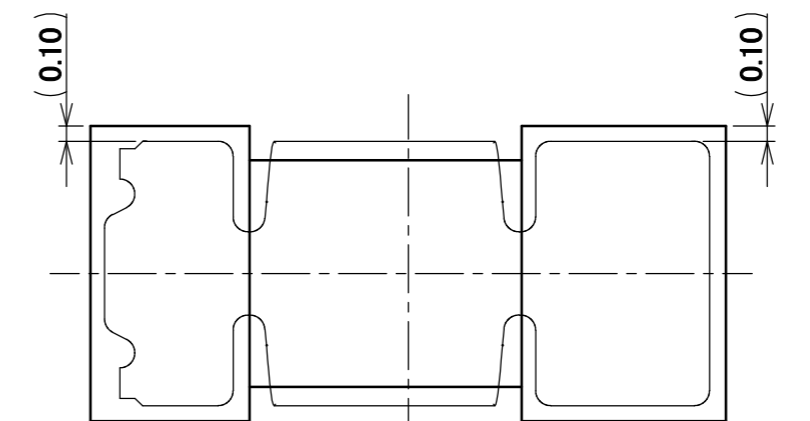

CONNECTOR ON RECOMMENDED FOOTPRINT PATTERN
3224-0003

NOTES.
 2. PATTERN AND RESIST PROHIBITION AREA.
 3. THIS AREA CANNOT MOUNT ANOTHER COMPONENTS.

ANGLE	±2°	6 OVER 30 MAX.	±0.3	PROJECTION 	SERIES No. R0	CUSTOMER COPY		
	6 MAX.	±0.2	30 OVER 120 MAX.					±0.5
GENERAL TOLERANCE.				TITLE		SCALE	I-PEX	
DWG.	DATE			MP-A04		20:1		
CHK.	DATE					UNIT		mm
APP.	DATE					DWG. No.		3224
						SIZE	A3	
						SHEET	5/7	
						REV.	3	

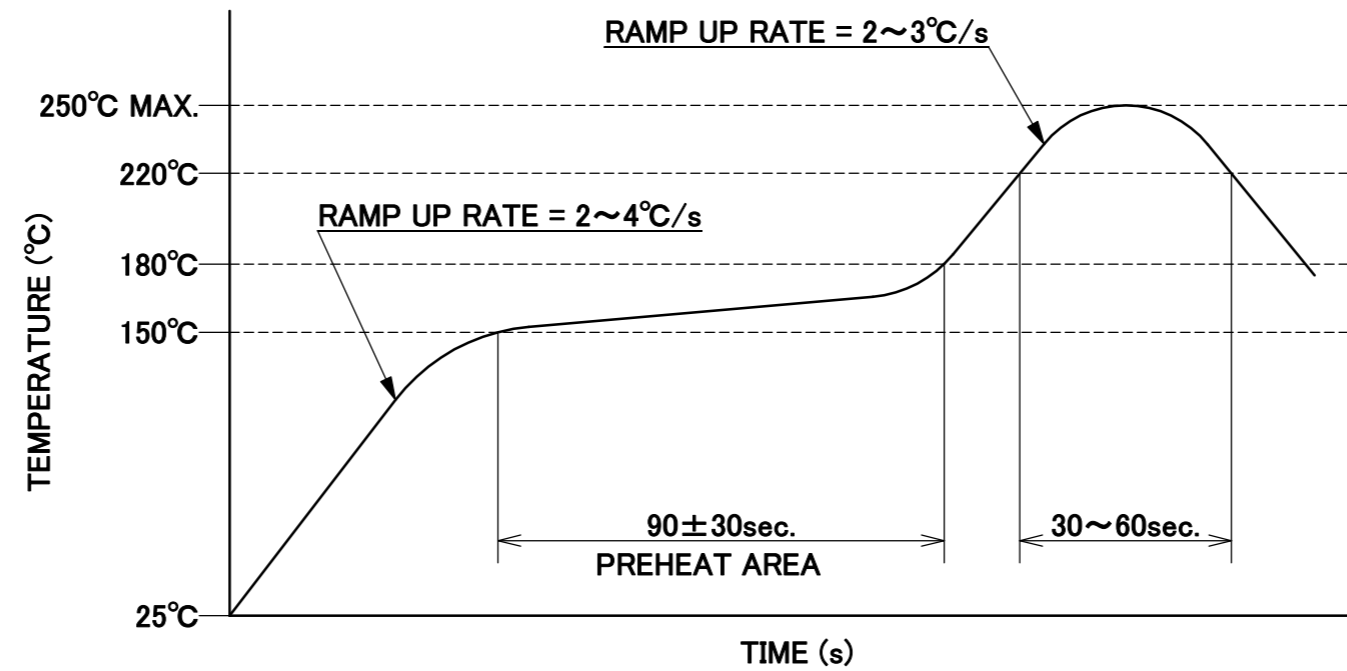

REFLOW TEMPERATURE PROFILE
SENJU METAL INDUSTRY CO., LTD. : M705-SHF(Sn96.5 Ag3.0 Cu0.5)

ANGLE	±2°	6 OVER 30 MAX.	±0.3	PROJECTION 	SERIES No. R0	CUSTOMER COPY		
6 MAX.	±0.2	30 OVER 120 MAX.	±0.5					
GENERAL TOLERANCE.				TITLE MP-A04	SCALE -	UNIT mm I-PEX		
DWG.	DATE							
CHK.	DATE							
APP.	DATE							
				DWG. No.	3224	SIZE A3	SHEET 6/7	REV. 3

PART NO.	A	QTY. PER EMBOSS REEL (PIECES / REEL)	QTY. PER PACKING CARTON (REELS / CARTON)
3224-0001	3.53	10,000 / REEL	10 REELS / CARTON = 100,000
3224-0003	4.13		

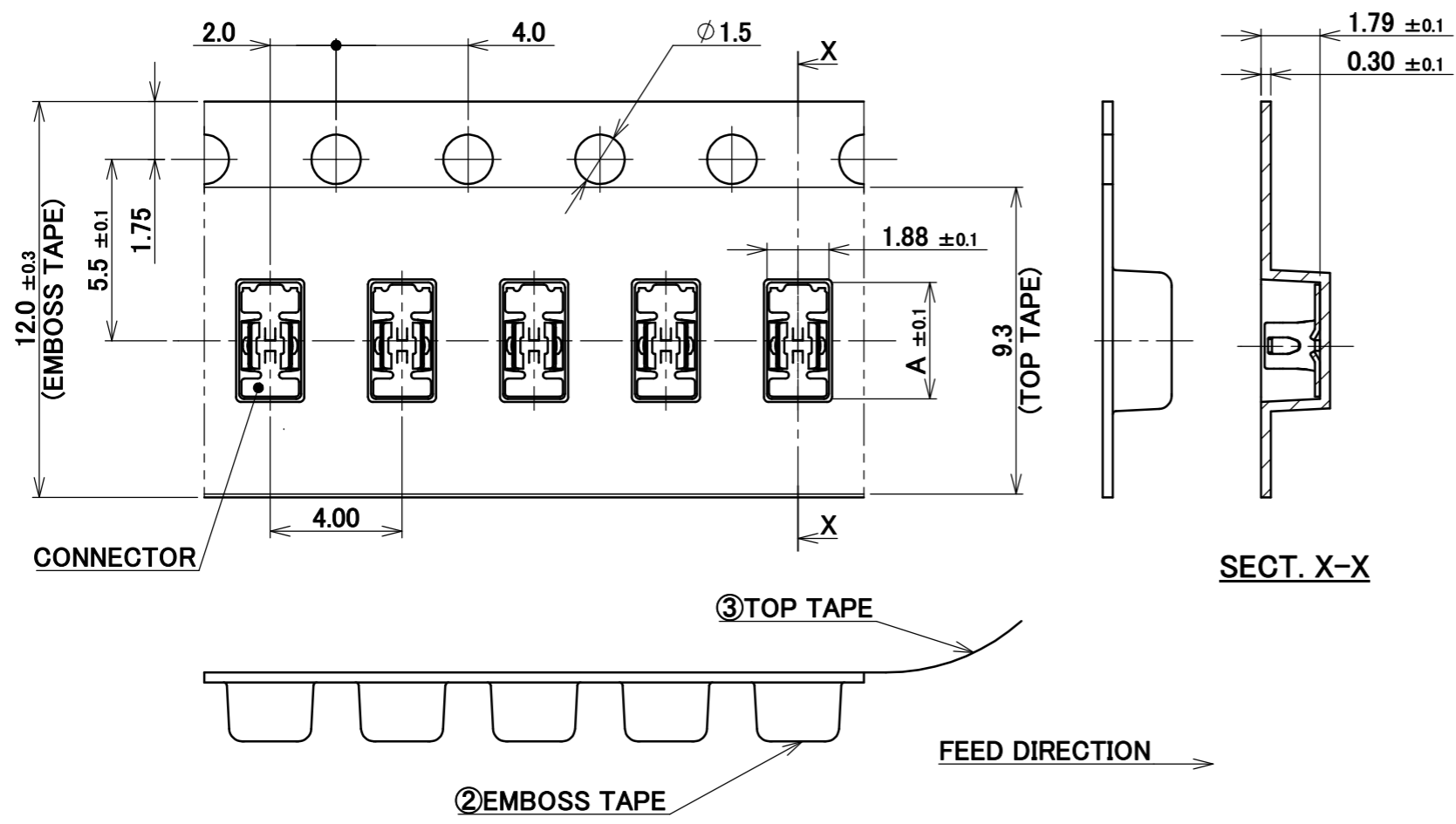
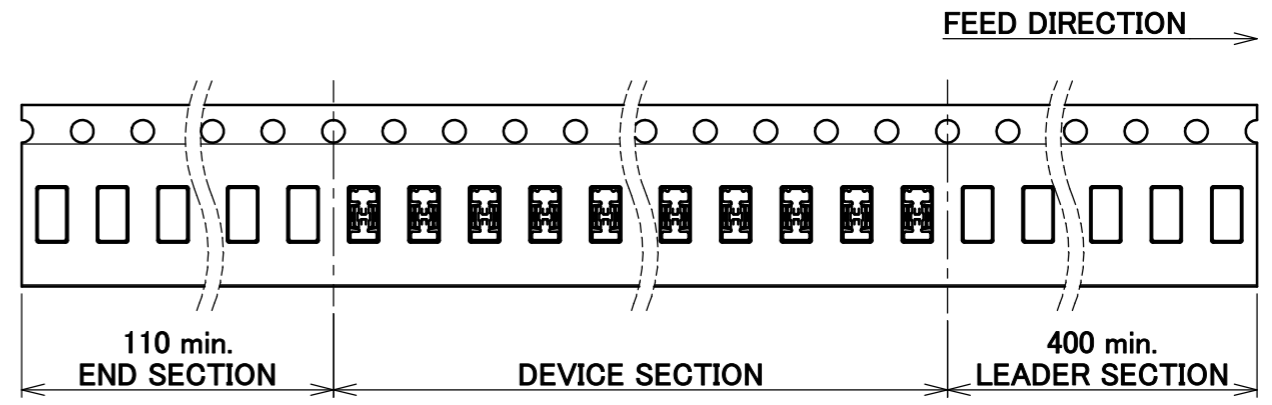
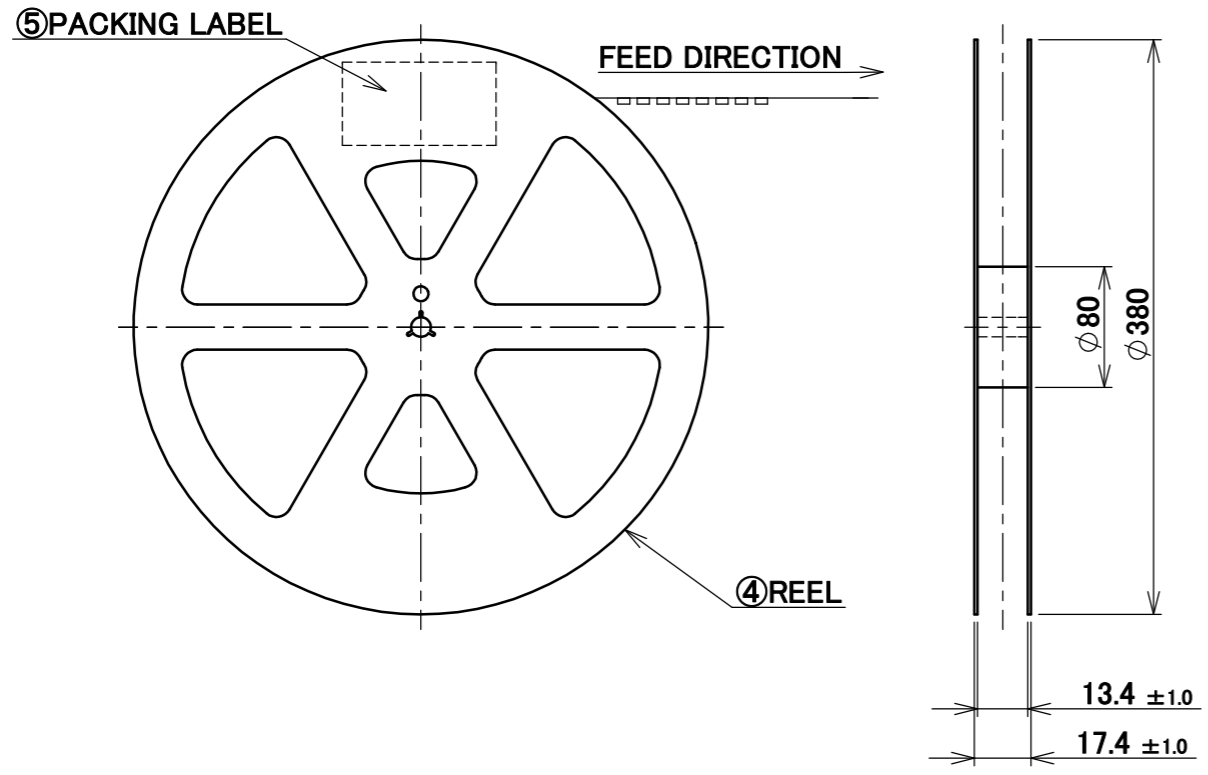

- NOTES.
- TAPING SPECIFICATION FOLLOWS JIS C 0806 (IEC 60286-3).
 - MAKE EMPTY SECTION OF LEADER AND END ON EACH END OF THE TAPE.
 - TOP TAPE SHALL NOT STICK OUT FROM EMBOSS TAPE.
 - TOP TAPE SHALL NOT COVER FEED HOLE.

NO.	DESCRIPTION	MATERIAL	FINISH , REMARKS
5	PACKING LABEL	-	-
4	REEL	PS	WHITE
3	TOP TAPE	PET TRANSPARENCY	-
2	EMBOSS TAPE	PS TRANSPARENCY	-

ANGLE	±2°	6 OVER 30 MAX.	±0.3	PROJECTION ⊕	SERIES No. R0	CUSTOMER COPY
	6 MAX.	±0.2	30 OVER 120 MAX.			
GENERAL TOLERANCE.				TITLE		SCALE X:1 UNIT mm SIZE A3
DWG.	DATE			MP-A04		
CHK.	DATE					
APP.	DATE			DWG. No. 3224		
						SHEET 7/7
						REV. 3