

Recommended P/N 20278-112R-**

PART No.	APPLICABLE CABLE
20278-112R-08	AWG#36 (0.81 O.D.)
20278-112R-13	AWG#32 (1.13 O.D.)
20278-112R-32	AWG#32 (1.32 O.D.)

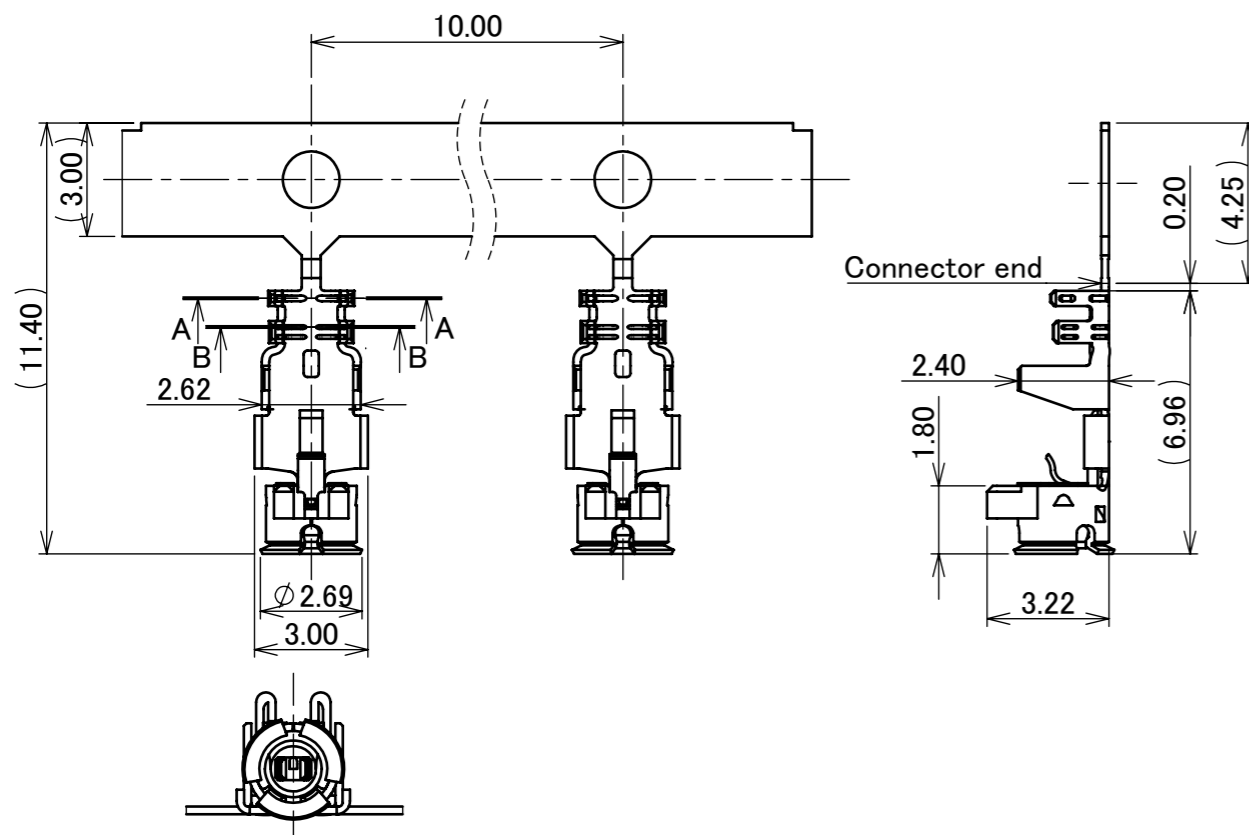
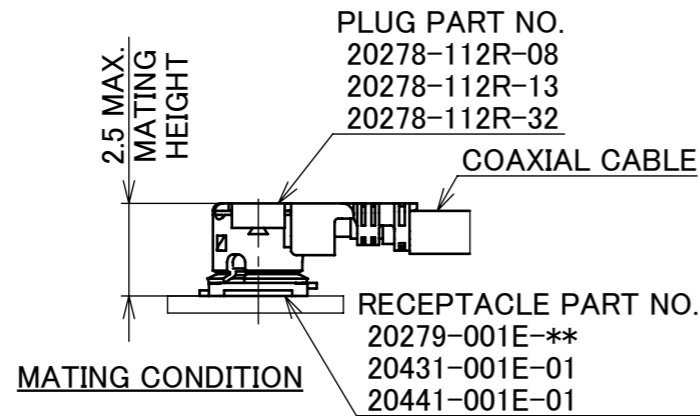
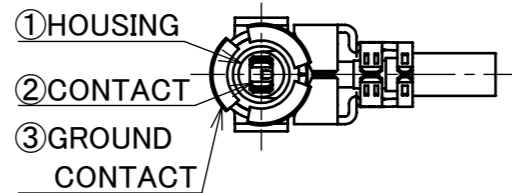
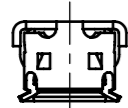
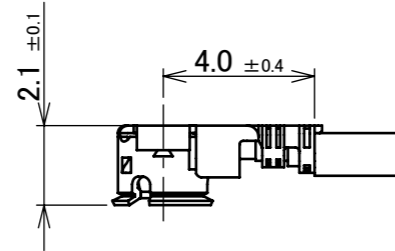
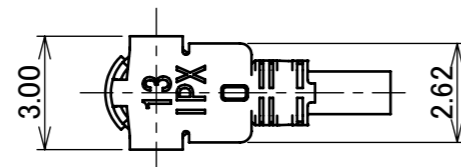
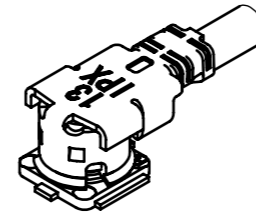

NOTES

- APPLICABLE CONNECTOR:
20279-001E-**, 20431-001E-01, 20441-001E-01
- PERMISSIBLE LOAD OF CABLE AT MATING
- SUGGESTIONS FOR MATING & UNMATING OPERATION.
 - MATING
PLEASE MATE THE CONNECTOR STRAIGHTLY TO VERTICAL DIRECTION AS MUCH AS POSSIBLE, ADJUSTING THE MATING AXIS OF PLUG AND RECEPTACLE. AS EXCESSIVE SLANT ANGLE MATING MAY BREAK THE CONNECTOR, PLEASE DON'T DO IT.
 - UNMATING
 - IN CASE OF UNMATING BY PULLING TOOL
PLEASE USE THE PULLING TOOL AS THE FOLLOWING DRAWING, AND PLEASE PULL PLUG TO VERTICAL DIRECTION AS DIRECTLY AS POSSIBLE.
 - IN CASE OF UNMATING DIRECTLY BY HAND
PLEASE CATCH THE CATCHING AREA OF PLUG, AND PLEASE PULL PLUG TO VERTICAL DIRECTION AS DIRECTLY AS POSSIBLE.
 - CRIMP OVER STANDARDS OF OUTER CONDUCTOR
STANDARDS: LESS THAN 10% FROM TOTAL NUMBERS OF OUTER CONDUCTOR.
(NUMBERS OF OUTER CONDUCTOR'S CRIMP OVER FROM OUTER CONDUCTOR'S BARREL)
 - CAUTION ABOUT HEAT SHRINKAGE TUBES
PLEASE BE CAREFUL NOT TO MELT HOUSING WHEN USING HEAT SHRINKAGE TUBES. IT WILL BECOME CAUSE OPEN CIRCUIT.
- THIS IS "PB-FREE" CONNECTOR.

NOTE 2.

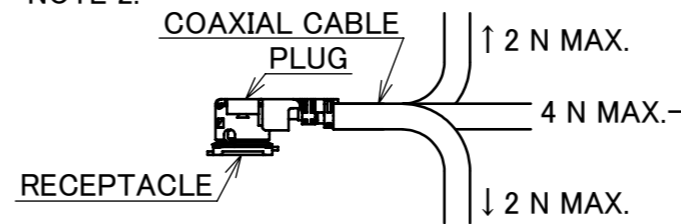

NOTE 3-2-1.

PULLING TOOL
PART NO. 90192-001

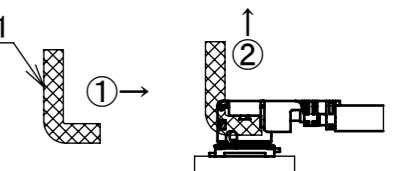

NOTE 3-2-2.

CATCHING AREA

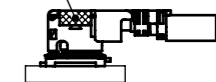

NO.	DESCRIPTION	MATERIAL	FINISH, REMARKS
3	GROUND CONTACT	PHOSPHOR BRONZE	ALL OVER Ni 1.00 μm MIN. CONTACT PART Au 0.05 μm MIN.
2	CONTACT	PHOSPHOR BRONZE	ALL OVER Ni 1.00 μm MIN. CONTACT PART Au 0.10 μm MIN.
1	HOUSING	PBT	UL94V-0, 20278-112R-08: WHITE 20278-112R-13, -32: BLACK

REV.	ECN	BY	DATE	APP.	APP.	APP.	APP.	PROJECTION	SERIES No.	TITLE	SCALE	SHEET	REV.
28	Z200262	TOI	2020/03/05	Y.H	ANGLE	±2°	6 OVER 30 MAX.	±0.3		R15	5:1	1/6	28
27	Z191013	Haji	2019/08/01	Y.S	6 MAX.	±0.2	30 OVER 120 MAX.	±0.5					
26	Z181428	M.N	2018/11/01	Ken	GENERAL TOLERANCE.					R15	5:1	1/6	28
25	Z180342	M.N	2018/03/27	Ken	DWG.	DATE		MHF® I PLUG (AU TYPE)					
24	Z171151	M.A	2017/10/05	T.M	K.Oobayashi		2001/07/13						
23	Z150949	K.T	2015/08/31	Tom	CHK.								
REV.	ECN	BY	DATE	APP.	APP.	APP.	APP.	DWG. No.	20278	A3	1/6	28	

PART No.	APPLICABLE CABLE
20278-112R-18	AWG#30 (1.80 O.D.)

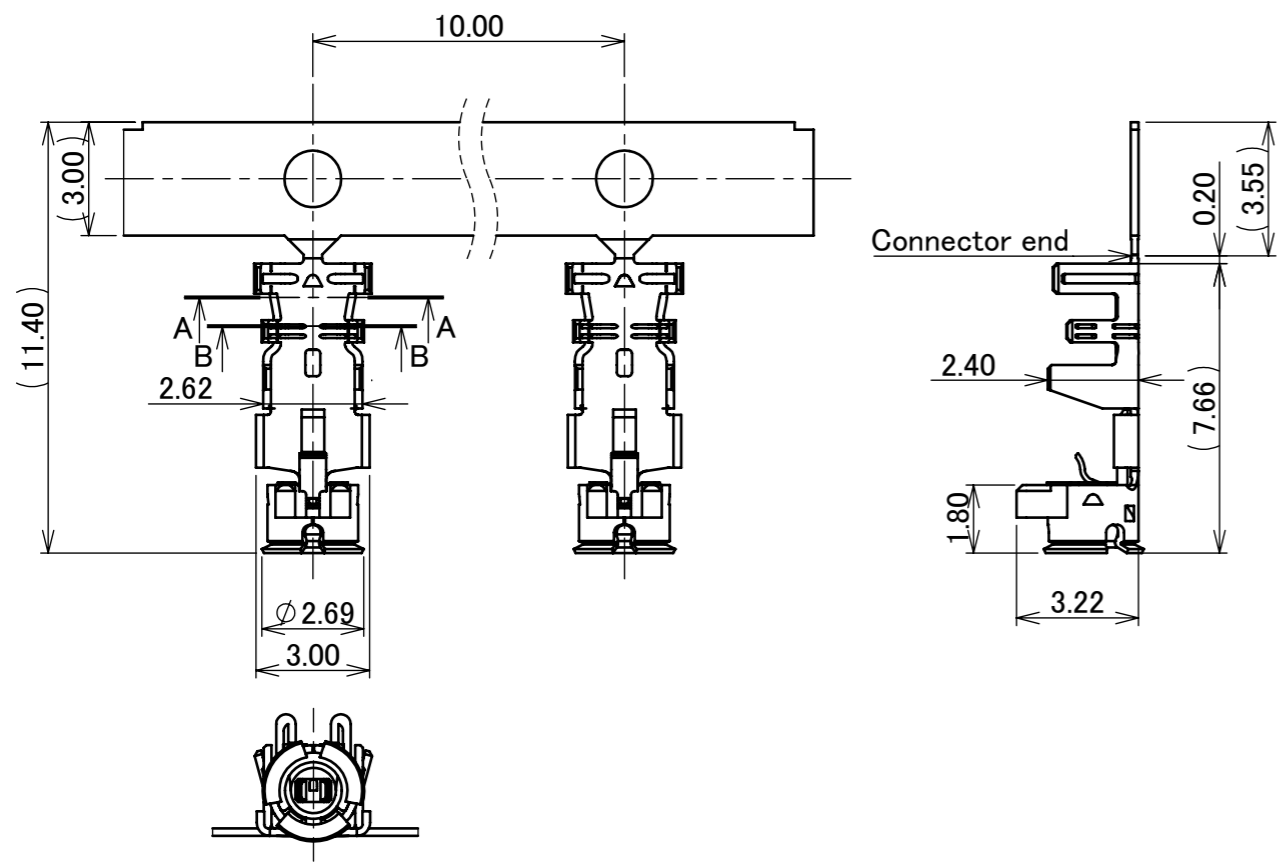
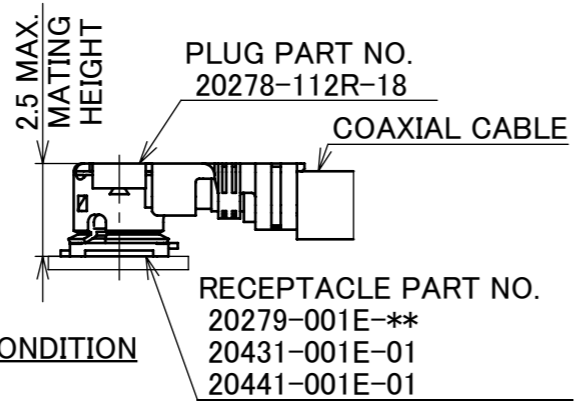
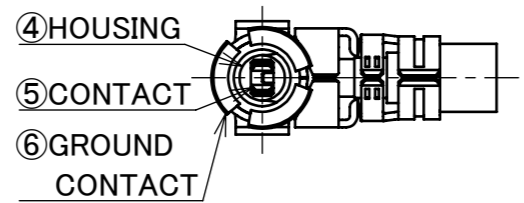
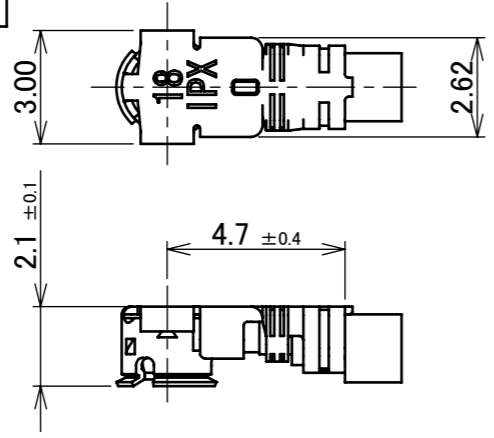
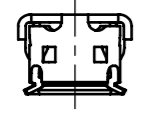
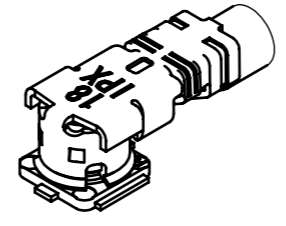

NOTES

5. APPLICABLE CONNECTOR:
20279-001E-**, 20431-001E-01, 20441-001E-01
6. PERMISSIBLE LOAD OF CABLE AT MATING
7. SUGGESTIONS FOR MATING & UNMATING OPERATION.
 - 7-1. MATING
PLEASE MATE THE CONNECTOR STRAIGHTLY TO VERTICAL DIRECTION AS MUCH AS POSSIBLE, ADJUSTING THE MATING AXIS OF PLUG AND RECEPTACLE. AS EXCESSIVE SLANT ANGLE MATING MAY BREAK THE CONNECTOR, PLEASE DON'T DO IT.
 - 7-2. UNMATING
 - 7-2-1. IN CASE OF UNMATING BY PULLING TOOL
PLEASE USE THE PULLING TOOL AS THE FOLLOWING DRAWING, AND PLEASE PULL PLUG TO VERTICAL DIRECTION AS DIRECTLY AS POSSIBLE.
 - 7-2-2. IN CASE OF UNMATING DIRECTLY BY HAND
PLEASE CATCH THE CATCHING AREA OF PLUG, AND PLEASE PULL PLUG TO VERTICAL DIRECTION AS DIRECTLY AS POSSIBLE.
 - 7-3. CRIMP OVER STANDARDS OF OUTER CONDUCTOR
STANDARDS: LESS THAN 10% FROM TOTAL NUMBERS OF OUTER CONDUCTOR.
(NUMBERS OF OUTER CONDUCTOR'S CRIMP OVER FROM OUTER CONDUCTOR'S BARREL)
 - 7-4. CAUTION ABOUT HEAT SHRINKAGE TUBES
PLEASE BE CAREFUL NOT TO MELT HOUSING WHEN USING HEAT SHRINKAGE TUBES. IT WILL BECOME CAUSE OPEN CIRCUIT.
8. THIS IS "PB-FREE" CONNECTOR.

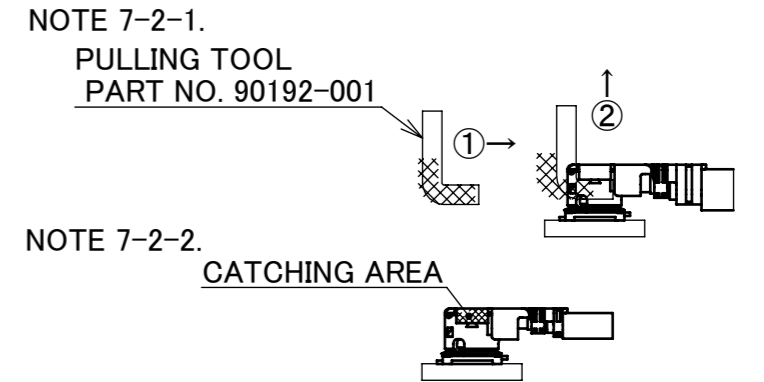
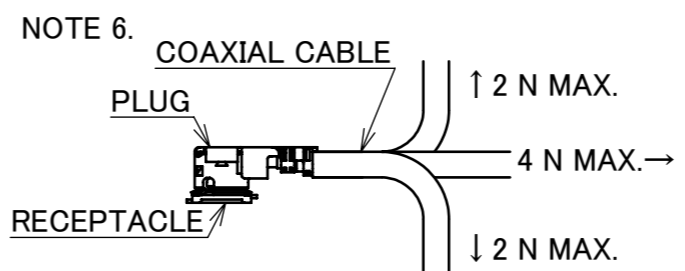

NO.	DESCRIPTION	MATERIAL	FINISH , REMARKS
6	GROUND CONTACT	PHOSPHOR BRONZE	ALL OVER Ni 1.00 μm MIN. CONTACT PART Au 0.05 μm MIN.
5	CONTACT	PHOSPHOR BRONZE	ALL OVER Ni 1.00 μm MIN. CONTACT PART Au 0.10 μm MIN.
4	HOUSING	PBT	UL94V-0, WHITE

ANGLE	±2°	6 OVER 30 MAX.	±0.3	PROJECTION ⊕	SERIES No. R15	CUSTOMER COPY						
6 MAX.	±0.2	30 OVER 120 MAX.	±0.5									
GENERAL TOLERANCE.				TITLE		SCALE	I-PEX					
DWG.	DATE			MHF® I PLUG (AU TYPE)		5:1						
CHK.						UNIT						
APP.				DWG. No. 20278		mm				SIZE	SHEET	REV.
						A3	2/6	28				

ITEMS	SPECIFICATION
RECOMMENDED APPLICABLE CONNECTOR PART No.	20279-001E-**
RATING VOLTAGE	60 V AC (R.M.S)
RATING FREQUENCY	DC~9GHz
OPERATING TEMPERATURE	233~363 K (-40°C~+90°C)
VSWR	1.3 MAX. AT 0.1~3 GHz, 1.5 MAX. AT 3~6 GHz, 1.9 MAX. AT 6~9 GHz
MAIN CONTACT RESISTANCE	INITIAL: 20 mohm MAX. / AFTER TEST: 25 mohm MAX.
GROUND CONTACT RESISTANCE	INITIAL: 10 mohm MAX. / AFTER TEST: 15 mohm MAX.
INSULATION RESISTANCE	INITIAL: 500 Mohm MIN. / AFTER TEST: 100 Mohm MIN.
DIELECTRIC WITHSTANDING VOLTAGE	200 V AC, 1 MINUTE
DURABILITY	30 CYCLES
UNMATING FORCE (INITIAL / AFTER TEST)	5 N MIN. / 3 N MIN.
CRIMP STRENGTH	20278-112R-08, 20278-112R-13, 20278-112R-32: 10 N MIN. 20278-112R-18: 15 N MIN.
PRODUCT SPECIFICATION	PRS-1676
TEST REPORT	TR-12044
PACKING STANDARD	300-233
INSTRUCTION MANUAL	HIM-10002
APPEARANCE CRITERIA No.	QLS-A***

ANGLE	±2°	6 OVER 30 MAX.	±0.3	PROJECTION 	SERIES No. R15	CUSTOMER COPY		
6 MAX.	±0.2	30 OVER 120 MAX.	±0.5					
GENERAL TOLERANCE.				TITLE MHF® I PLUG (AU TYPE)	SCALE 5:1	UNIT I-PEX		
DWG.	DATE							
CHK.								
APP.								
				DWG. No.	20278	SIZE A3	SHEET 3/6	REV. 28

PART NO.		20278-112R-08	20278-112R-13	20278-112R-32	20278-112R-18
APPLICABLE CABLE NOMINAL DIMENSION 					
BRAIDED SHIELD OF OUTER CONDUCTOR		SINGLE	SINGLE	DOUBLE	SINGLE
PART NO. OF HAND TOOL	PART NO. OF SEMI AUTO TERMINATION MACHINE	90187-008C	90187-013C	90187-032C	90233-018
		90213-008C	90213-013C	90213-032C	90232-018
SECT. B-B					
SECT. A-A					
CRIMP HEIGHT	CH-1	1.34~1.40	1.34~1.40	1.34~1.40	1.34~1.40
	CH-2	0.76~0.84	1.06~1.14	1.20~1.30	1.41~1.49
	CH-3	0.85~0.97	1.15~1.35	1.26~1.46	1.70~1.80

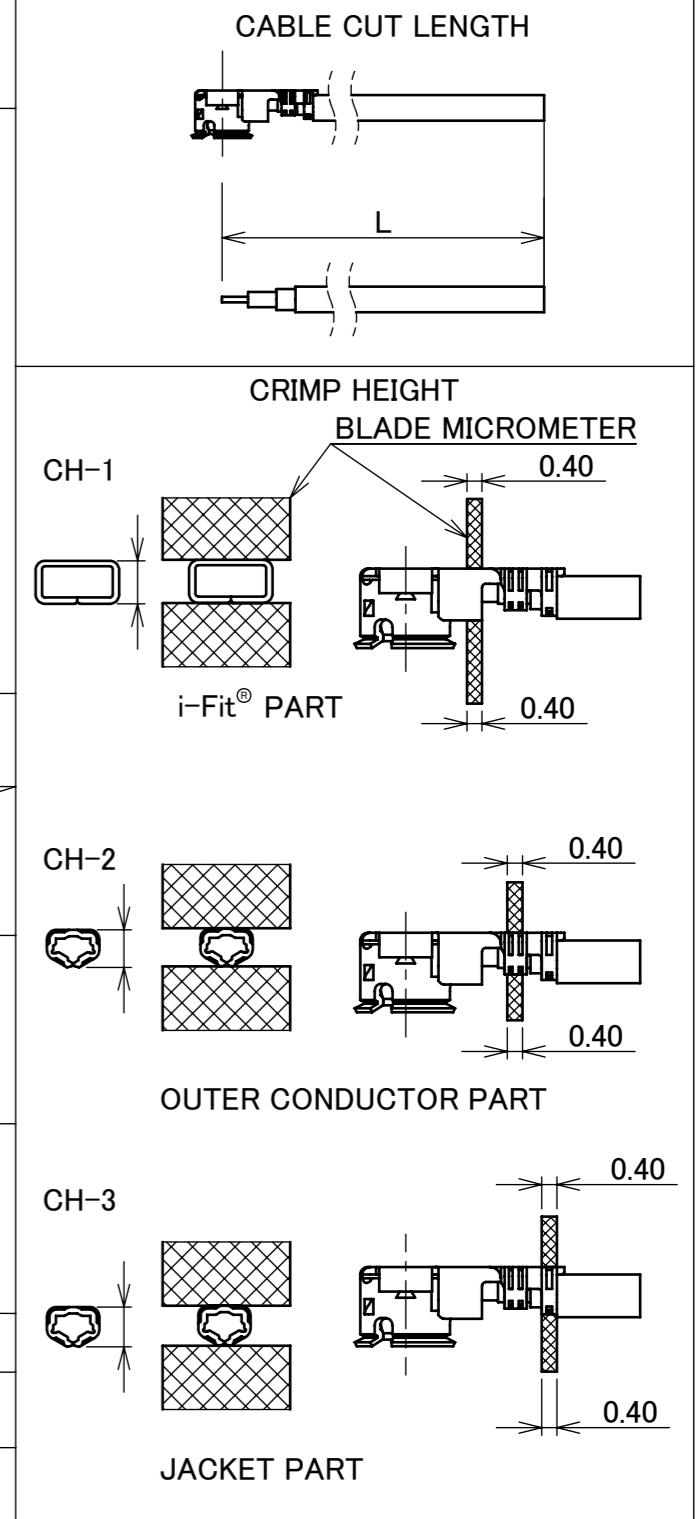

NOTE 9. MUST NOT USE SOLDER COATED INNER CONDUCTOR AND OUTER CONDUCTOR.

ANGLE	±2°	6 OVER 30 MAX.	±0.3	PROJECTION ⊕	SERIES No. R15	CUSTOMER COPY					
	6 MAX.	±0.2	30 OVER 120 MAX.						±0.5		
GENERAL TOLERANCE.				TITLE	SCALE	I-PEX					
DWG.	DATE			MHF® I PLUG (AU TYPE)	5:1						
CHK.					UNIT				mm		
APP.				DWG. No.	20278				SIZE	SHEET	REV.
						A3	4/6	28			

PART NO.	A	QTY. PER EMBOSS REEL (PIECES / REEL)	QTY. PER PACKING CARTON (REELS / CARTON)
20278-112R-**	20.0	2,500 / REEL	4 REELS / CARTON = 10,000 PIECES

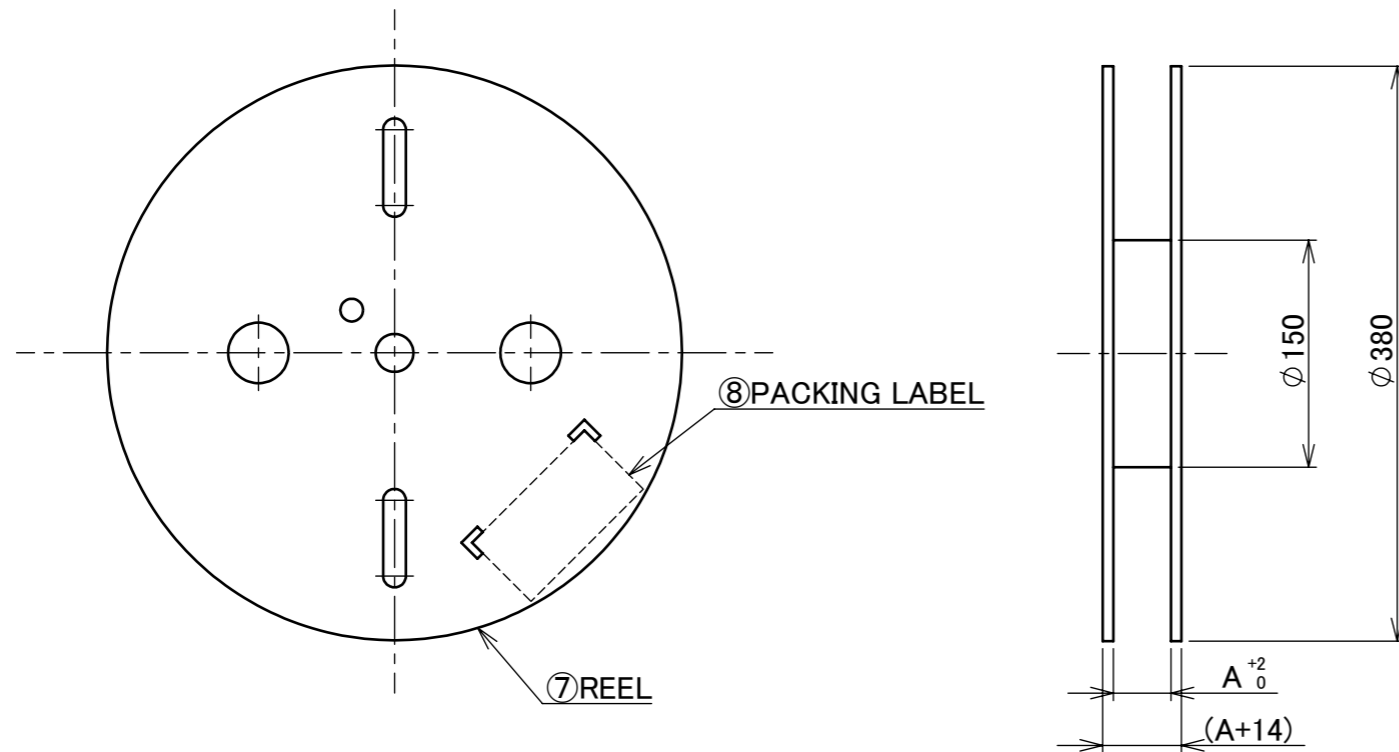

8	PACKING LABEL	-	-
7	REEL	CB	-
NO.	DISCRIPTION	MATERIAL	FINISH , REMARKS

ANGLE	$\pm 2^\circ$	6 OVER 30 MAX.	± 0.3	PROJECTION 	SERIES No. R15	CUSTOMER COPY			
6 MAX.	± 0.2	30 OVER 120 MAX.	± 0.5						
GENERAL TOLERANCE.				TITLE MHF® I PLUG (AU TYPE)	SCALE 1:1	I-PEX			
DWG.	DATE								UNIT mm
CHK.									SIZE A3
APP.									SHEET 5/6
				DWG. No.	20278				

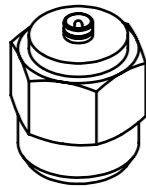

MHF I/II SMA ADAPTOR
PART NO. 90193-001

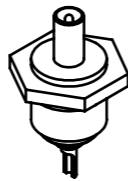

MHF I/II PLUG INSPECTION CONNECTOR
PART NO. 90194-001



FRONT SIDE BACK SIDE
MHF I/II PULLING TOOL
PART NO. 90192-001

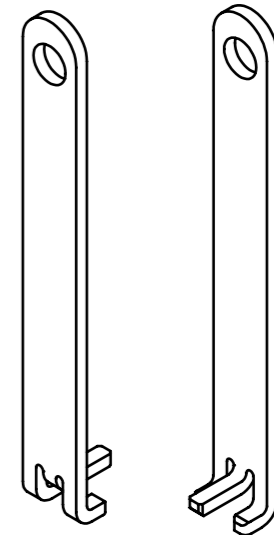

FRONT SIDE BACK SIDE
MHF I PUSHING AND PULLING TOOL
PART NO. 90224-001

ANGLE	±2°	6 OVER 30 MAX.	±0.3	PROJECTION ⊕	SERIES No. R15	CUSTOMER COPY		
6 MAX.	±0.2	30 OVER 120 MAX.	±0.5					
GENERAL TOLERANCE.				TITLE MHF® I PLUG (AU TYPE)	SCALE 2:1	UNIT I-PEX		
DWG.	DATE							
CHK.								
APP.								
				DWG. No.	20278	SIZE A3	SHEET 6/6	REV. 28